

Line-02
Shredding of on-spec material

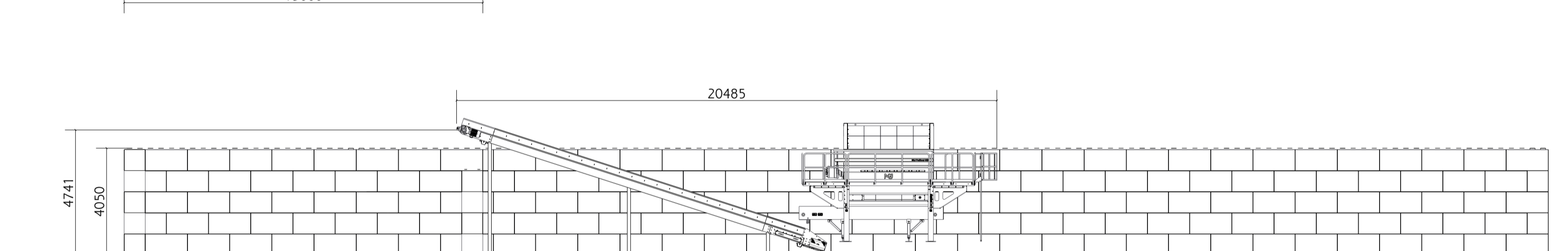

Line-01
Bale opener line

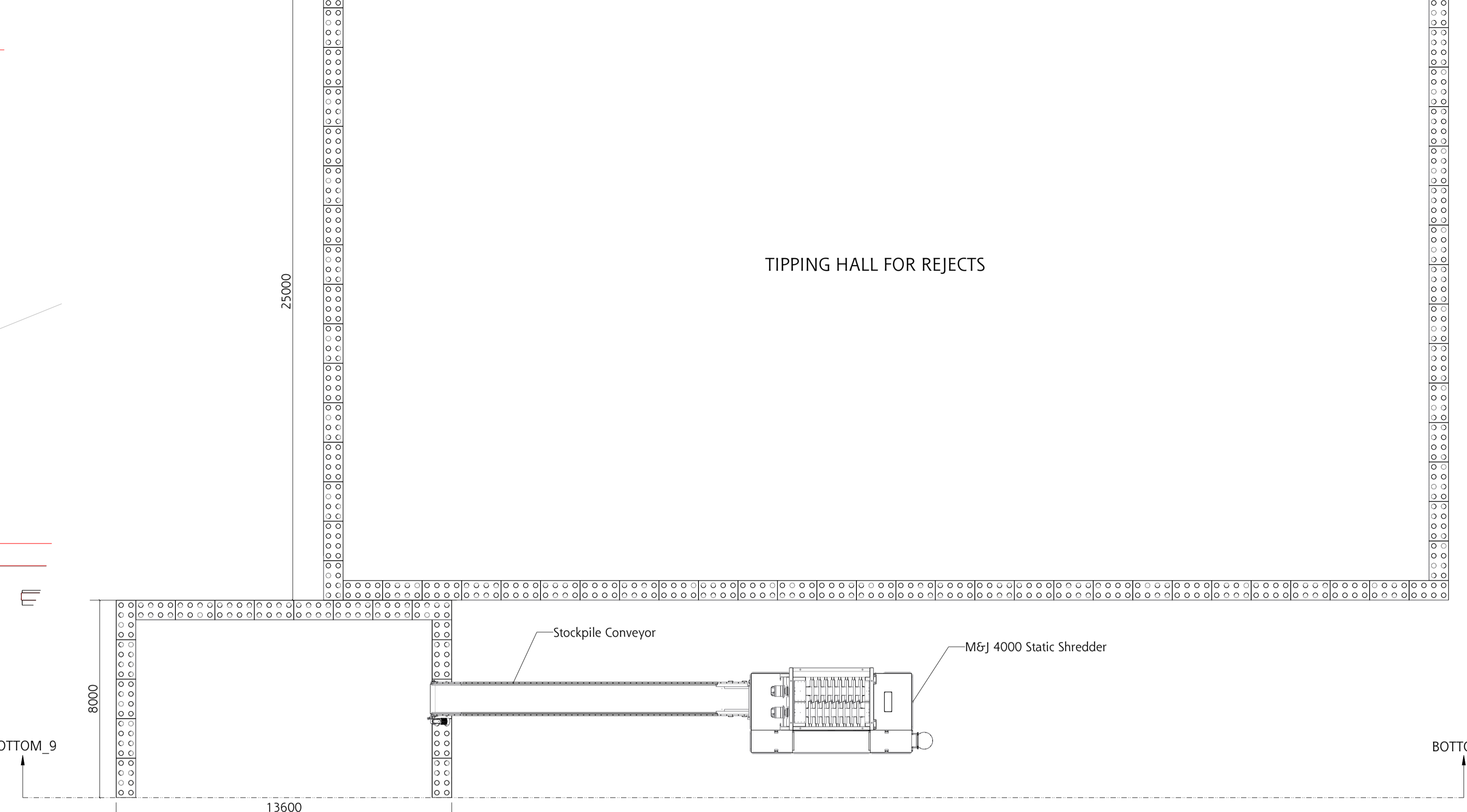
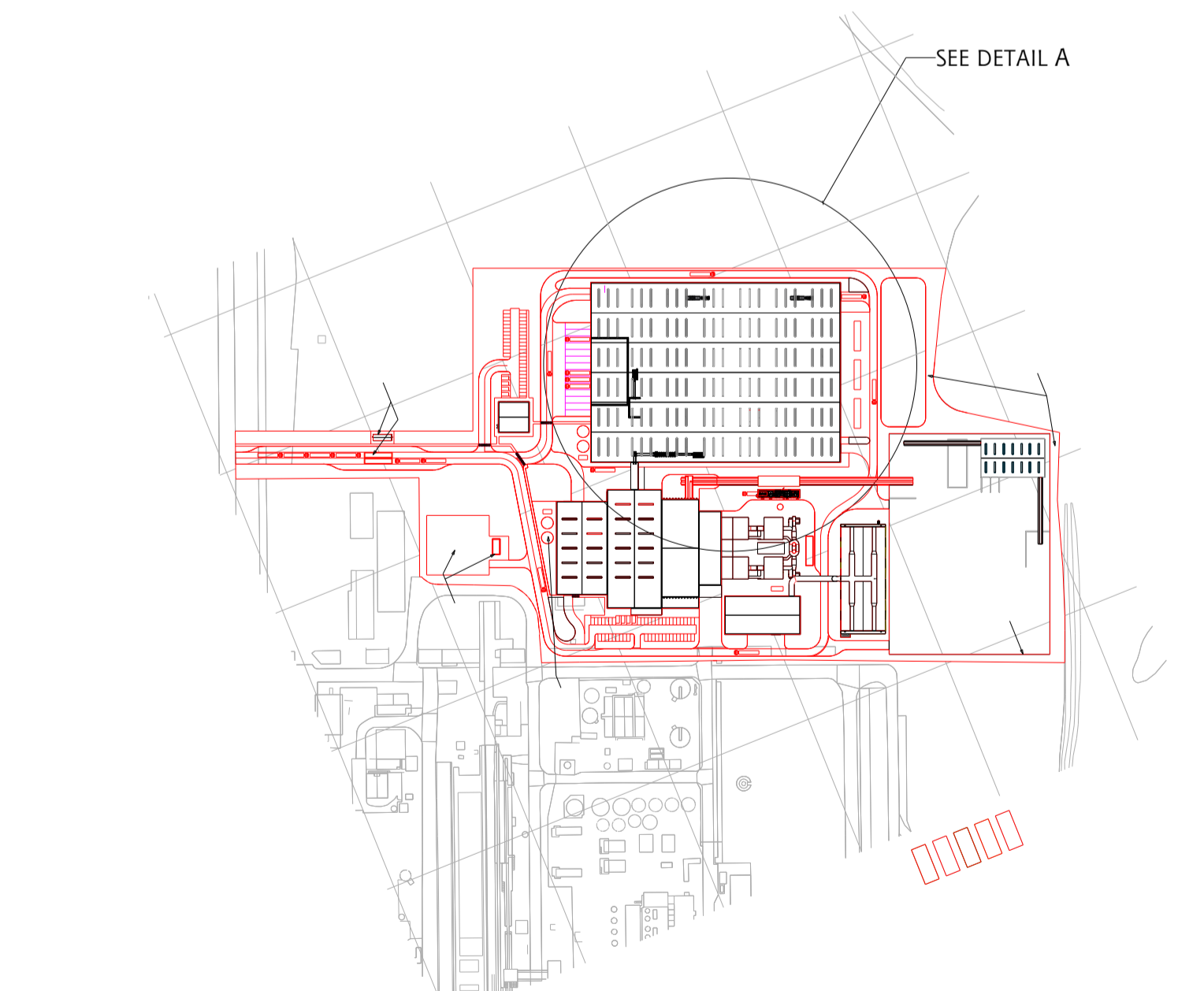
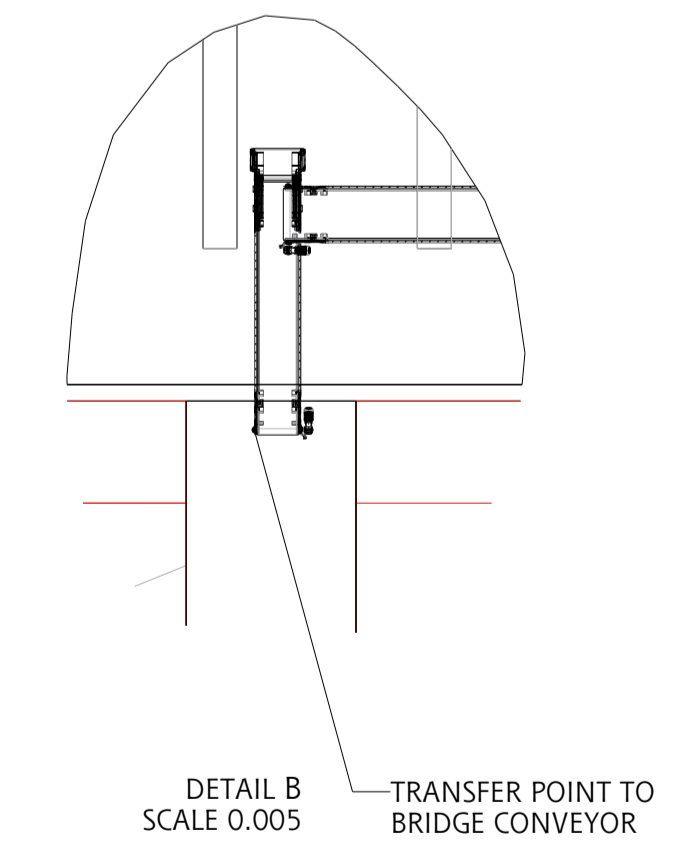
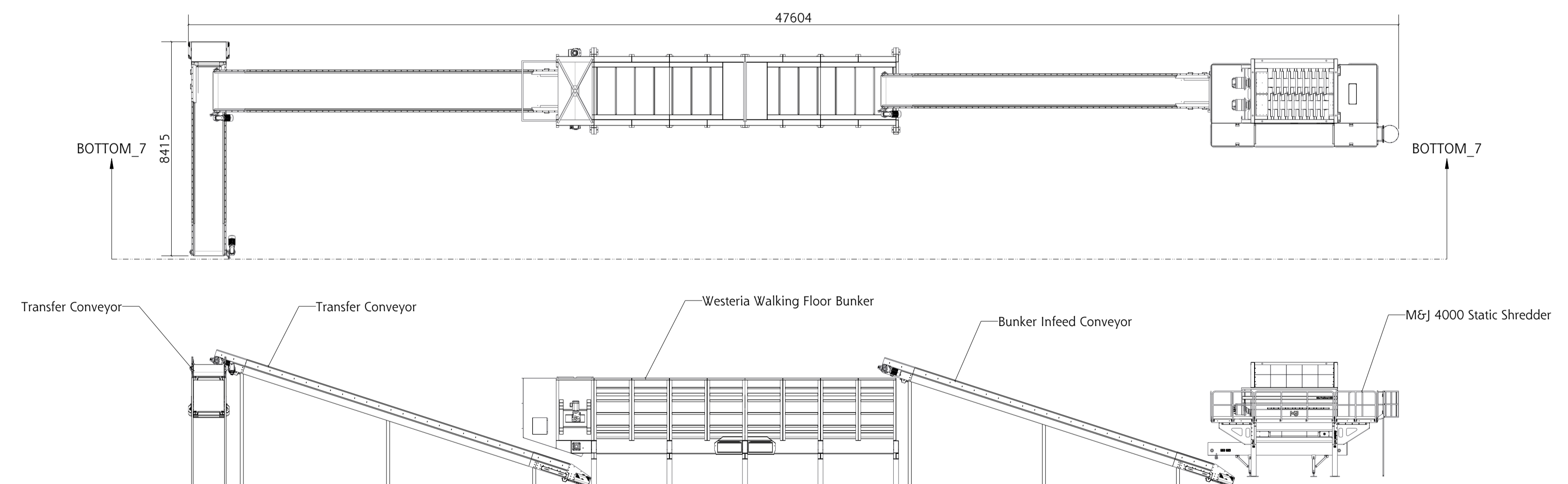

REVISIONS						
REV.	EDR	DESCRIPTION	BY	CHECKED	APPROVED	DATE
A						
B						
C						
D						
E						
F						

GENERAL TOLERANCES UNLESS OTHERWISE SPECIFIED
TOLERANCES TO ISO 2768 - m

SIZE FROM TO	0.5	6	30	120	400	1000	2000	4000
TOLERANCE	± 0.1	± 0.2	± 0.3	± 0.5	± 0.8	± 1.2	± 2.0	± 3.0

HURST

Hurst Engineering Services Limited
Unit C12 Omagh Enterprise Centre
Great Northern Road
Omagh
Co. Tyrone
BT78 5LU
Telephone: +44 (0) 79 350 368 22 Email: engineering@hursteng.co.uk

THE DESIGN SHOWN ON THE DRAWING IS THE PROPERTY OF HURST DESIGN AND IS NOT TO BE USED, COPIED, DISCLOSED OR COMMUNICATED IN WHOLE OR IN PART, EXCEPT IN ACCORDANCE WITH A CONTRACT, LICENSE OR AGREEMENT IN WRITING WITH ABOVE NAMED COMPANY

THIRD ANGLE PROJECTION

DRAWN BY	05001	DATE	27-06-23
CHECKED BY	05002	DATE	27-06-23
MATERIAL	DRAWING No.		
FINISH	As Noted	MASS	31373850.855 kg

DO NOT SCALE IF IN DOUBT ASK

SIZE	A1
REV	A.O.
SCALE	0.008
SHEET	1 / 1