

Hinkley Point C Cooling Water Infrastructure Fish Protection Measures:
Report To Discharge DCO requirement CW1 and Marine Licence Condition
5.2.31

March 2016

[This page is intentionally left blank]

CONTENTS

INTRODUCTION

1	INTRODUCTION	7
2	REQUIREMENT CW1 AND CONDITION 5.2.31	8
3	STRUCTURE AND SCOPE OF THIS REPORT	12

SYSTEM DESCRIPTION

4	COOLING WATER INTAKES	16
5	FOREBAY (HPF)	28
6	COOLING WATER PUMP HOUSE (HP)	30
7	FILTERING DEBRIS RECOVERY PIT (HCB)	55
8	FISH RETURN SYSTEM (HCF)	65
9	COOLING WATER OUTFALL	75

COMPLIANCE, JUSTIFICATION AND IMPACT ASSESSMENT

10	COMPLIANCE WITH EA FISH PROTECTION DOCUMENTS	85
11	INTAKES	86
12	INTAKE SHAFTS AND TUNNELS	96
13	FOREBAY (HPF)	104
14	COOLING WATER PUMP HOUSE (HP)	115
15	DEBRIS (TRASH) RECOVERY BUILDING (HCB)	130
16	RETURN TO SEA (HCF)	135
17	OUTFALL HEAD	139

SUMMARY

18	SUMMARY	141
19	REFERENCES	147
20	APPENDICES	149

[This page is intentionally left blank]

ACRONYMS

The following acronyms will be used in the report.

Acronym	Meaning
AFD	Acoustic Fish Deterrent System
APC	Air Plane Crash
bar	Pressure in bars above atmospheric pressure
BS	Band Screen
CEFAS	Centre for Ecology, Fisheries and Aquaculture Science
CIMP	Comprehensive Impingement Monitoring Programme
CFI	Water Filtration System
CRF	Circulation/Cooling Water System
DCO	Development Consent Order
EA	Environment Agency
EHWL	Extreme High Water Level
ELWL	Extreme Low Water Level
EPR	European Pressurized (water) Reactor
ES	Environmental Statement
FRR	Fish Recovery and Return
HAT	Highest Astronomical Tide
HCB	Filtered Debris Recovery Building
HPB	Hinkley Point B
HPC	Hinkley Point C
HP	Cooling Water Pump House
LAT	Lowest Astronomical Tide
LVSE	Low velocity, side entry
MMO	Marine Management Organisation
NNB GenCo (HPC) Ltd	NNB Generation Company (HPC) Limited
NE	Natural England
NRW	Natural Resources Wales
ODN	Ordnance Datum

OPEX	OPerating EXperience
SEC	Essential Services Water System
SEF	Intake coarse filtration and trash removal system
SEN	Auxiliary Cooling Water System
SRU	Ultimate Cooling Water System

1 INTRODUCTION

- 1.1.1 On 19 March 2013, the Secretary of State issued a Development Consent Order (DCO) to NNB Genco to build and operate a nuclear power station at Hinkley Point (HPC). The new power station will comprise 2 UKEPR™ units (hereafter, referred to as EPR) that will operate for 60 years, each with the capacity to produce 1650MW(e). The new station (the 'C' station) will be the third nuclear power station to be built at Hinkley Point, and will be built immediately to the west of the existing 'A' station (which is now being decommissioned), which itself lies to the west of the 'B' station (still in operation).
- 1.1.2 HPC will be 'direct-cooled', that is, it will abstract water from the sea in Bridgwater Bay to cool its steam condensers (and other heat exchangers), before returning that same water back into Bridgwater Bay at an elevated temperature (of around 11°C higher than at the intake). In order to abstract the 125 m³ per second required for this cooling process, a large system of cooling water tunnels will extend out into Bridgwater Bay, under the sea bed, before linking to the sea via vertical shafts and associated headworks. As part of the design of the cooling water system, a Fish Recovery and Return (FRR) system will be built, that will include a tunnel extending approximately 600 metres under the foreshore, to return entrapped fish back to the sea.
- 1.1.3 The Marine and Coastal Access Act 2009 requires any construction activity (amongst other things) in the sea, including tunnelling beneath the seabed, to be licensed by the Marine Management Organisation (MMO). On 7 June 2013, the MMO issued a Marine Licence for NNB GenCo (HPC) Ltd to build the cooling water infrastructure (as well as other licensable activities associated with the construction and operation of HPC) (L2013/00178).
- 1.1.4 Both the DCO and the Marine Licence have pre-construction obligations that NNB Genco (HPC) Ltd must fulfil prior to starting construction of the cooling water infrastructure. These obligations are defined in DCO Requirement CW1 and Marine Licence Condition 5.2.31, and essentially request details of the design and location of the various cooling water infrastructure components, as well as stipulating that the design must be best practice. All details must be approved by the MMO.
- 1.1.5 This paper provides the information required by Requirement CW1 (Paragraph 1) and Condition 5.2.31 (all), needing approval by the MMO for discharge of those obligations.
- 1.1.6 It should be noted that the design information provided in this document is based primarily on conceptual and basic design studies. There will be an additional detailed design phase prior to manufacturing, construction and/or installation and, as such, the information will potentially be subject to minor variations which will undergo rigorous assessment to ensure that they continue to meet their design intent. This is standard practice in design phasing for complex infrastructure projects.

2 REQUIREMENT CW1 AND CONDITION 5.2.31

2.1.1 As the Development Consent Order (DCO) was issued 3 months earlier than the Marine Licence, there was a need for repetition of this obligation on both Permissions, however, for consistency, the MMO used the same words in its Licence condition as those used in the DCO Requirement. Both are cited below.

2.2 DCO Requirement CW1: Cooling water infrastructure design

2.2.1 Requirement CW1 states:

“(1) No development shall commence until details of Work Nos. 2A to 2H have, following consultation with the Countryside Council for Wales, Natural England, English Heritage and the Environment Agency, been submitted to and approved by the Marine Management Organisation. The details shall include —

(a) the location and design (size and shape) of the off-shore intake and outfall heads;

(b) the alignment (horizontal and vertical) of the cooling water intake and outfall tunnels; and

(c) the location and design of the fish recovery and return system and the low velocity side entry intakes, which shall be in accordance with the Environment Agency guidance referenced in the Environmental Statement (Volume 2, chapter 2, paragraph 2.6.21).

(2) The acoustic fish deterrent system shall not be installed until details of the location and design have, following consultation with the Countryside Council for Wales, Natural England and the Environment Agency, been submitted to and approved by the Marine Management Organisation.

(3) No water abstraction shall commence until the off-shore intake and outfall heads, cooling water intake and outfall tunnels, the fish recovery and return system, the low velocity side entry intakes and the acoustic fish deterrent system have been installed in accordance with the approved details referred to in paragraphs (1) and (2).”

2.2.2 For clarity, Works Numbers 2A to 2H are presented in Table 1 (Full details are presented in Appendix B):

Table 1: Description of DCO Works Numbers

Work Number	Description
2A	Intake tunnel for EPR Unit 1
2B	2 x Intake Heads for EPR Unit 1, Vertical Shafts, Acoustic Fish Deterrents and Navigational Aids (attached to 2A)
2C	Intake tunnel for EPR Unit 2
2D	2 x Intake Heads for EPR Unit 2, Vertical Shafts, Acoustic Fish Deterrents and Navigational Aids (attached to 2C)
2E	Outfall tunnel serving both EPR Units
2F	2 x Outfall Heads for the outfall tunnel (attached to 2E)
2G	Outfall tunnel for Fish Recovery and Return System
2H	Outfall head for FRR tunnel (attached to 2G)

2.3 Marine Licence Condition 5.2.31

2.3.1 Condition 5.2.31 states:

“No development shall commence until the following activity details have, following consultation with Natural Resources Wales, Natural England, English Heritage and the Environment Agency, been submitted to and approved by the MMO.

The details shall include:

- (a) the location and design (size and shape) of the offshore intake and outfall heads*
- (b) the alignment (horizontal and vertical) of the cooling water intake and outfall tunnels, and*
- (c) the location and design of the fish recovery and return system and the low velocity side entry intakes, which shall be in accordance with the Environment Agency guidance referenced in the Environmental Statement (Volume 2, chapter 2, paragraph 2.6.21).*

Reason: to protect the marine environment.”

2.4 Environment Agency guidance

2.4.1 Both the DCO Requirement and Marine Licence Condition refer to the Environmental Statement that NNB GenCo (HPC) Ltd produced to support its DCO submission (Ref [1]) and Environment Agency guidance (Refs [2] [3]). The DCO paragraph referred to (2.6.21, Chapter 2, Volume 2) states:

“The general principles applied to the design of the system will be in accordance with the general guidance published by the Environment Agency (Ref. 2.1 and 2.2). The overall arrangement of the FRR system is illustrated in the sectional drawing provided in Figure 2.15”

- 2.4.2 References 2.1 and 2.2 are “Cooling water options for the new generation of nuclear power stations in the UK” (Environment Agency 2010) (Ref [3]) and “Screening for intake and outfalls: a best practice guide” (Environment Agency 2005) (Ref [2]), respectively.
- 2.4.3 During consultation with the Environment Agency, the design of the FRR system has also been compared for compliance with “*Screening at intakes and outfalls: measures to protect eel*” (Ref [4]) for compliance with the Eels (England and Wales) Regulations 2009.
- 2.4.4 The optimisation of the design of the buildings, structures, systems and components covered by this submission has been carried out to ensure that they perform their primary functions (i.e. provision of adequate and reliable supply of cooling water to meet all plant operating states) taking into account a range of other variables including:
- Nuclear safety;
 - Industrial safety;
 - Fish protection;
 - Other environment and sustainability concerns;
 - Constructability;
 - Operability and operator burden;
 - Maintenance burden;
 - Supplier experience; and
 - Cost (proportionality assessment)

Consideration of all of the above factors show that the design options selected are considered to represent Best Available Techniques (BAT) for HPC, when judged against the legally accepted BAT definitions presented in both the OSPAR¹ agreement and the Industrial Emissions Directive².

- 2.4.5 The OSPAR Convention states:

BAT “means the latest stage of development (state of the art) of processes, of facilities or of methods of operation which indicate the practical suitability of a particular measure for limiting discharges, emissions and waste” and “the application of the most appropriate combination of environmental control measures and strategies”.

The Industrial Emissions Directive states:

‘best available techniques’ means the most effective and advanced stage in the development of activities and their methods of operation which indicates the practical suitability of particular techniques for providing the basis for emission limit values and other permit conditions designed

¹ 1992 Oslo & Paris (OSPAR)_Convention for the Protection of Marine Environment of the North-East Atlantic (http://www.ospar.org/site/assets/files/1290/ospar_convention_e_updated_text_in_2007_no_revs.pdf)

² Directive 2010/75/EU of the European Parliament and of the Council of 24 November 2010 on industrial emissions (integrated pollution prevention and control) (Recast) (<http://eur-lex.europa.eu/legal-content/EN/TXT/PDF/?uri=CELEX:32010L0075&from=en>)

to prevent and, where that is not practicable, to reduce emissions and the impact on the environment as a whole:

(a) 'techniques' includes both the technology used and the way in which the installation is designed, built, maintained, operated and decommissioned;

(b) 'available techniques' means those developed on a scale which allows implementation in the relevant industrial sector, under economically and technically viable conditions, taking into consideration the costs and advantages, whether or not the techniques are used or produced inside the Member State in question, as long as they are reasonably accessible to the operator;

(c) 'best' means most effective in achieving a high general level of protection of the environment as a whole;

2.4.6 It should also be noted that contractors are chosen using a holistic approach that includes a number of assessment criteria (including environmental and market credentials), so that in many cases, the chosen supplier is the leader in the technological field in which it operates.

2.4.7 The success of this approach can be demonstrated through the selection of Ovivo as the preferred supplier for the drum, band and coarse screens for HPC. Ovivo are the market leader in the design and supply of cooling water filtration system, having previously design and supplied filtration plant for Pembroke CCGT and Longannet coal fired power stations. Whilst the majority of the fish friendly evolutions in the design information for these filters/screens will influence the fish friendliness of the filters/screens to be installed at HPC, NNB Genco (HPC) does not have access to, and therefore cannot provide, proprietary design information as this remains the property of Ovivo, RWE and/or Scottish Power.

3 STRUCTURE AND SCOPE OF THIS REPORT

3.1 Structure

- 3.1.1 Although Requirement CW1 and Marine Licence Condition 5.2.31 require details of the cooling water infrastructure location and design as a whole, their overarching aims are to demonstrate that the cooling water infrastructure meets best practice with regards to fish protection measures. As stated, best practice is defined in two Environment Agency documents
- 3.1.2 This report is structured such that fish protection measures are described in the sequence in which entrained fish would encounter them in the HPC cooling water system. Table 1 lists the cooling water components in the order that a fish will encounter them; these components are also shown in Figures 1 and 2.

3.2 Scope

- 3.2.1 Paragraph 2 of DCO requirement CW1 refers to another mitigating feature of the cooling water infrastructure, namely the proposed Acoustic Fish Deterrent (AFD) that will produce sound at the intake heads to deflect fish with well-developed hearing anatomies away from the intake (see 2.1.1).
- 3.2.2 When CW1 was written and agreed, the design of the AFD system was deliberately de-coupled from the rest of the infrastructure in Requirement CW1 because the technology is novel and would require bespoke application at HPC and it was felt that confirming the design would have held up construction unnecessarily. The Marine Licence is written slightly differently, and the design of the AFD system is covered by a completely separate Condition.
- 3.2.3 Therefore, and for the avoidance of doubt, this paper only deals with Paragraph 1 of CW1 and does not cover the design of the AFD system. Where necessary, however, the AFD will be referred to in respect of its potential anticipated mitigating effects where these complement the FRR system and, thus, contribute to the overall fish protection measures of HPC.

Table 2: Components of the Cooling Water System

Number	Description	HPC Building / System	Chapter / section
1	Acoustic Fish Deterrent (AFD)	Cooling water intakes	N/A
2	Low Velocity, side-entry (LVSE) intake head		4.3
3	Intake shaft		4.4
4	Intake tunnel		4.5
5	Forebay	Forebay (HPF)	5
6	Debris rack and rake	Cooling water pump house (HP)	6.1
7	Bandscreen		6.2
8	Drum screen		6.3
9	Connection gutters		6.4
10	Filtering debris recovery pit (HCB) basin	Filtering debris recovery pit (HCB)	7.4
11	Debris rack and rake		7.1.19
12	Archimede's screw		7.1.26
13	Fish return gutter	Fish return system (HFT)	8.1.4
14	Fish return transition structure		8.1.15
15	Fish return tunnel		8.1.22
16	Fish return outfall structure		8.1.35
17	Outfall tunnel	Cooling water outfalls	9.3
18	Outfall shaft		9.4
19	Outfall head		9.5

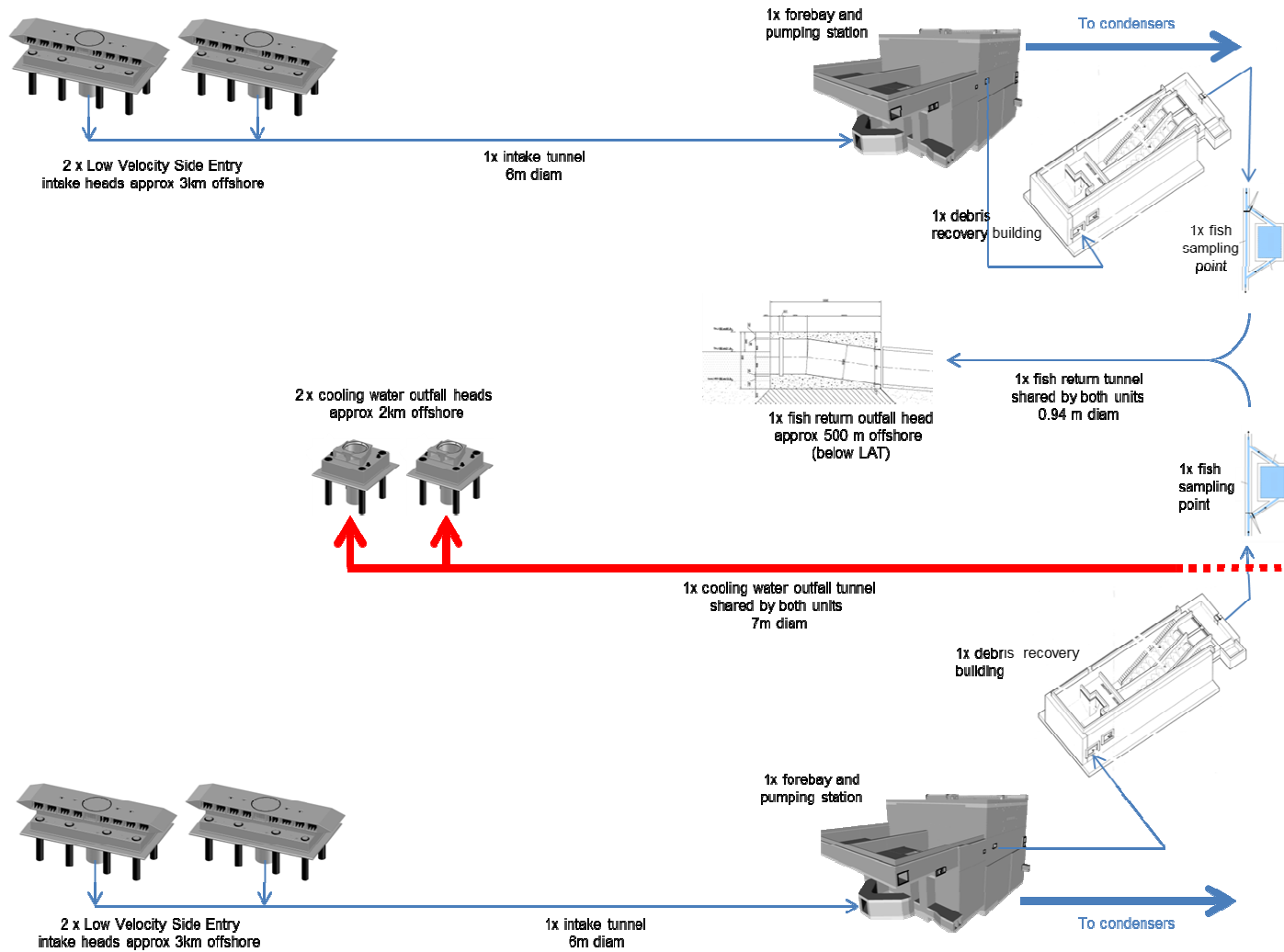

Figure 1: Overall schematic of cooling water system and Fish Recovery and Return (FRR) system

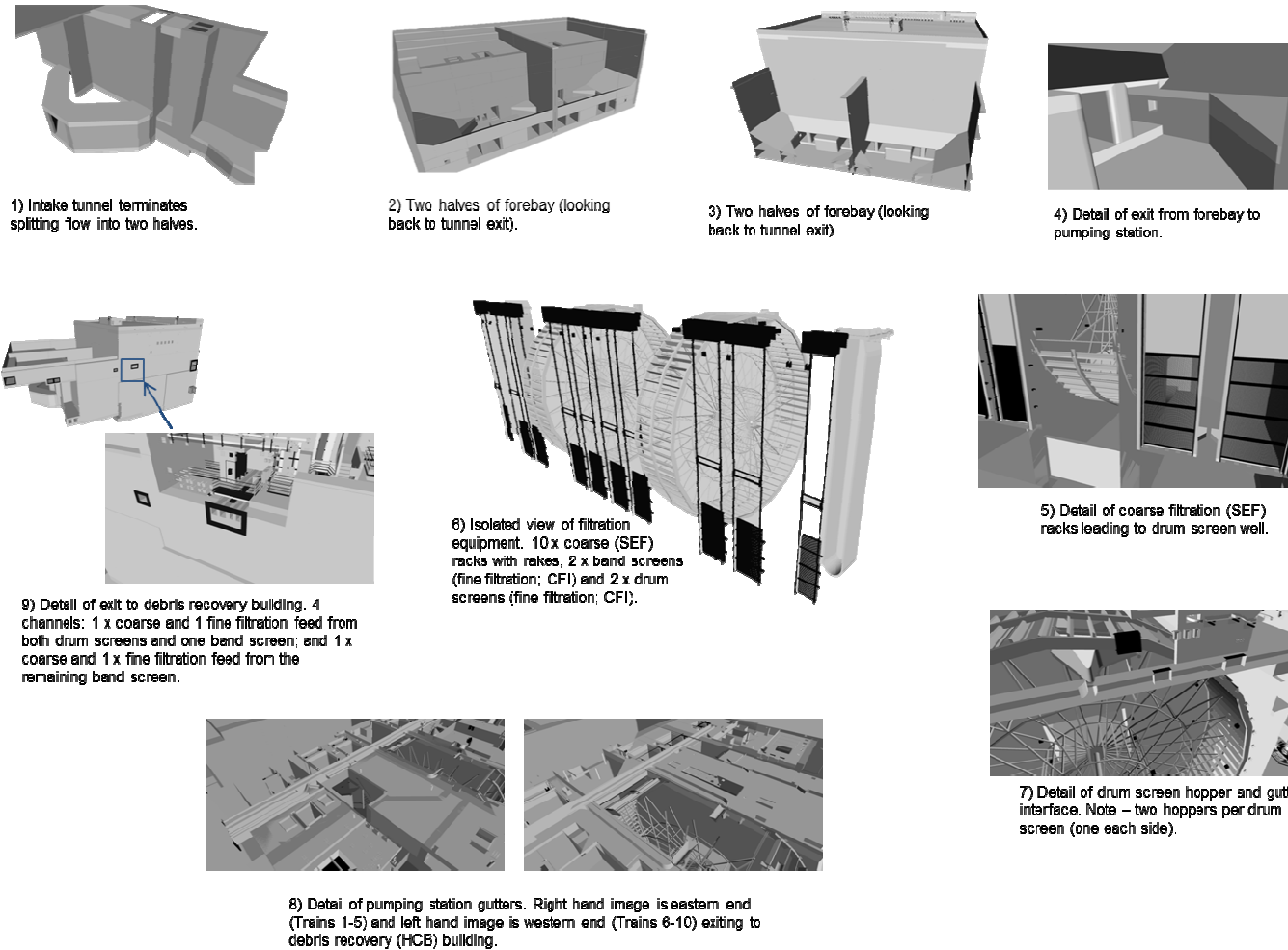

Figure 2: Overall schematic of Forebay (HPF) and Cooling water pump house (HP)

4 COOLING WATER INTAKES

4.1 General description

- 4.1.1 Hinkley Point C will comprise 2 x EPR reactor units that will have a combined requirement of 125 m³ s⁻¹ seawater cooling. Each reactor unit, hereafter referred to as Units, will have its own intake tunnel extending out into the Bristol Channel. Each tunnel will terminate with 2 sets of headworks, each set comprising an intake head on the seabed and a vertical shaft linking the head to the tunnel.
- 4.1.2 Both Units will share a common outfall tunnel, again extending out into the Bristol Channel. This tunnel will terminate with 2 sets of headworks, each set comprising an outfall head on the seabed and a vertical shaft linking the head to the tunnel.

4.2 Location of intakes

- 4.2.1 Design of the heat sink (the means by which the station loses the heat from its condensers) is an extremely important aspect of system design for nuclear power stations, in terms of both safety and efficiency as well as environmental impacts.
- 4.2.2 From an operational perspective, a number of factors have to be considered when choosing the location of cooling water intakes. The site should:
- (i) be able to provide a supply of suitable water that will be constant and consistent over the operational lifetime of the station;
 - (ii) be geologically suitable (i.e. comprises suitable bedrock for construction and is inactive³ in respect of faulting or tectonic movements);
 - (iii) not cause a hazard to navigation by ships (to minimise risk of impact on the headworks);
 - (iv) be sufficiently far away from the associated cooling water outfall headworks, so that water discharged from the outfall is not taken in by the intake.⁴
 - (v) be as close to the station as possible to reduce the pumping capacity required by the system cooling water system⁵.
 - (vi) should not be exposed to large amounts of debris, such as seaweed, jetsam or other litter which might block the intake apertures.
- 4.2.3 From an environmental perspective, the intakes must be sited such that they do not abstract large amounts of aquatic fauna, including larval or egg life-stages.
- 4.2.4 In reality, the heat sink needs to be considered holistically. For example, at (iv) above, the location of the associated outfall works is noted as a constraint on the location of the intakes but, of course, the location of the outfall headworks is itself also constrained by certain criteria (see Section 9.5).
- 4.2.5 Finally, for Hinkley Point C specifically, consideration also had to be taken of the operational Hinkley Point B power station. The cooling water intake and outfall works are located several hundred metres offshore of Hinkley Point, and cognisance of both potential recirculation issues (for both stations) and

³ Even though geologically inactive locations are chosen, the headworks and tunnels are built to be able to withstand earthquakes.

⁴ Water discharged by the outfall will be approximately 11° C warmer than ambient, and so if this water is 're-circulated' into the intake it has less cooling capacity than ambient seawater, making the heat sink cooling process less efficient.

⁵ The longer the tunnels are, the more friction there is in the system which requires larger pumps to be installed to pump the water.

environmental impacts with both stations operating in-combination needed to be made when locating the Hinkley Point C intakes.

- 4.2.6 With all of the above in mind, the cooling water intake headworks for Hinkley Point C are approximately 3km offshore north-north-west of the Hinkley Point C site.
- 4.2.7 Each unit has a separate intake tunnel, to which 2 intake heads are connected. The intakes on each tunnel are approximately 200 m apart. The two tunnels are approximately 450 m apart. This spatial separation is to provide redundancy so that the station can continue to operate should one of the individual intakes become unavailable.
- 4.2.8 The precise locations of the intake heads are presented in Table 3, where co-ordinates are presented as 3 points along the axis, running centrally through the structure as shown in Figure 3.

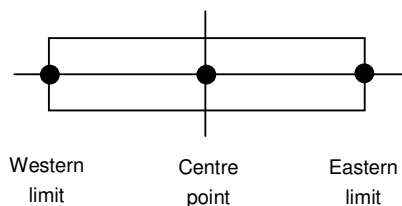

Figure 3: Intake co-ordinate points.

Table 3: Co-ordinates of the offshore intake heads (see Figure 4)

Unit & Intake	Location	Grid Reference	Latitude	Longitude
Unit 1, Intake 1	Western Limit	ST 18569 48839	51.232904	-3.1677029
	Centre Point	ST 18590 48843	51.232943	-3.1674031
	Eastern Limit	ST 18612 48847	51.232982	-3.1670889
Unit 1, Intake 2	Western Limit	ST 18454 49003	51.234361	-3.169387
	Centre Point	ST 18476 49007	51.234401	-3.1690729
	Eastern Limit	ST 18497 49011	51.234440	-3.1687731
Unit 2, Intake 1	Western Limit	ST 18114 48692	51.231517	-3.1741846
	Centre Point	ST 18136 48696	51.231556	-3.1738705
	Eastern Limit	ST 18158 48699	51.231586	-3.1735562
Unit , Intake 2	Western Limit	ST 17992 48850	51.232920	-3.1759678
	Centre Point	ST 18013 48854	51.232959	-3.175668
	Eastern Limit	ST 18035 48857	51.232989	-3.1753536

- 4.2.9 In respect of the Environment Agency’s best practice reports (Refs [2] and [3]), the siting of the Hinkley Point C intakes fulfils all of the required criteria. The intakes are:
- (i) located a long way offshore, located away from any intertidal or saltmarsh areas;
 - (ii) located away from known fish migratory routes;
 - (iii) located away from known fish spawning or nursery grounds;
 - (iv) located in an open, free-flowing section of the Bristol channel where volume of debris (storm wrack etc.) is predicted to be low.

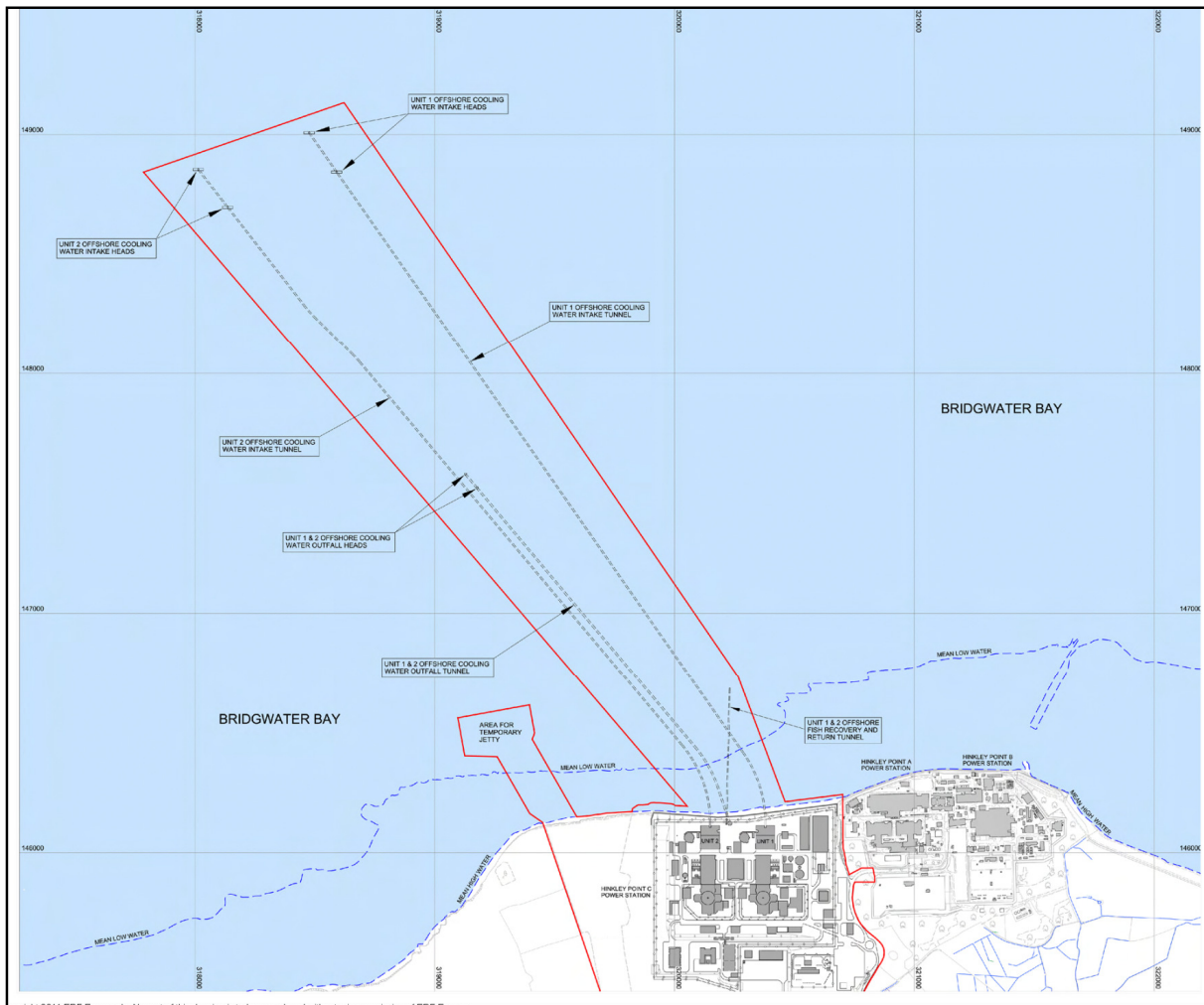

Figure 4: Locations of the intake headworks and intake tunnels (also showing outfall headworks and tunnels and Fish Return (HCF) tunnel and outfall (ref. [1]). See Appendix B for A3.

4.3 Intake heads

- 4.3.1 The Hinkley Point C intake head design remains identical to that described in the Development Consent Order (DCO) Environmental Statement (Ref [1]). It is a rectangular, Low Velocity Side-Entry (LVSE) intake designed by Jacobs (Ref [5]), using principles described in the Environment Agency's "Best Practice" for screening at intakes and outfalls (Ref [2]).
- 4.3.2 The structure is rectangular with a total size of 43.90 m x 10.00 m x 2.80 m. The structure has an isometric wedge shaped 'nose' structure at each end, and the distribution chamber (the intake section) itself is 35.50 m long. Along the two sides are apertures for water to enter the structure; these apertures have baffles within them to prevent the entry of large pieces of debris. The lower sill of the intake apertures will be approximately 1 m above the sediment level of the seabed.
- 4.3.3 The combined abstraction rate of the two Units at Hinkley Point C will be approximately $125 \text{ m}^3 \text{ s}^{-1}$ (depending on tidal state), so each individual intake head will abstract approximately $31.25 \text{ m}^3 \text{ s}^{-1}$.
- 4.3.4 The Low Velocity Side Entry design is based on three key principles to allow fish in the vicinity the maximum opportunity to escape being drawn in with the water:
- (i) intake flow rates should be slow (i.e. slower than the 'burst' swimming speed of fish) so that they can swim away from the intake, provided they are able to detect it;
 - (ii) in addition to (i) the apertures to the intake head should be perpendicular to the current flow, so that intake velocities are not added to by current/tidal flow; and
 - (iii) the intake should draw in water sideways, because fish are more able to escape from a horizontal current than they are from a vertical current.
- 4.3.5 The HPC intake head design achieves all three of these objectives.
- 4.3.6 The design for the installation of an associated Acoustic Fish Deterrent (AFD) system will take cognisance of the intake head design objectives and be designed in such a manner that it does not impact the performance of the intake heads.
- 4.3.7 The intake heads have 3 types of vertical structures: walls at 3.5m centres (to provide structural integrity), 'baffles' at 0.85m centres (to help standardise intake flows) and bars at 0.26m centres to prevent large pieces of debris from entering the intake.
- 4.3.8 The design of the Hinkley Point C Low Velocity Side Entry (LVSE) intake head is presented in Figures 5 - 7. The dimensions are presented in Table 4.

Table 4: Dimensions of the LVSE intake head

Parameter	Dimensions (m)
Overall length	43.90
Length of distribution chamber	35.50
Length of nose sections	4.20
Height of intake section	2.80
Width	10.00
Width of the 3 baffle sections towards ends	3.50
Width of central baffle section	11.30
Width between individual baffles	0.85
Width between 3no. bars between baffles	0.26



Figure 5: 3 Dimensional views of the intake heads (Type 1 on the left and Type 2 on the right; only the foundations are different; hydraulic performance are the same for both types)

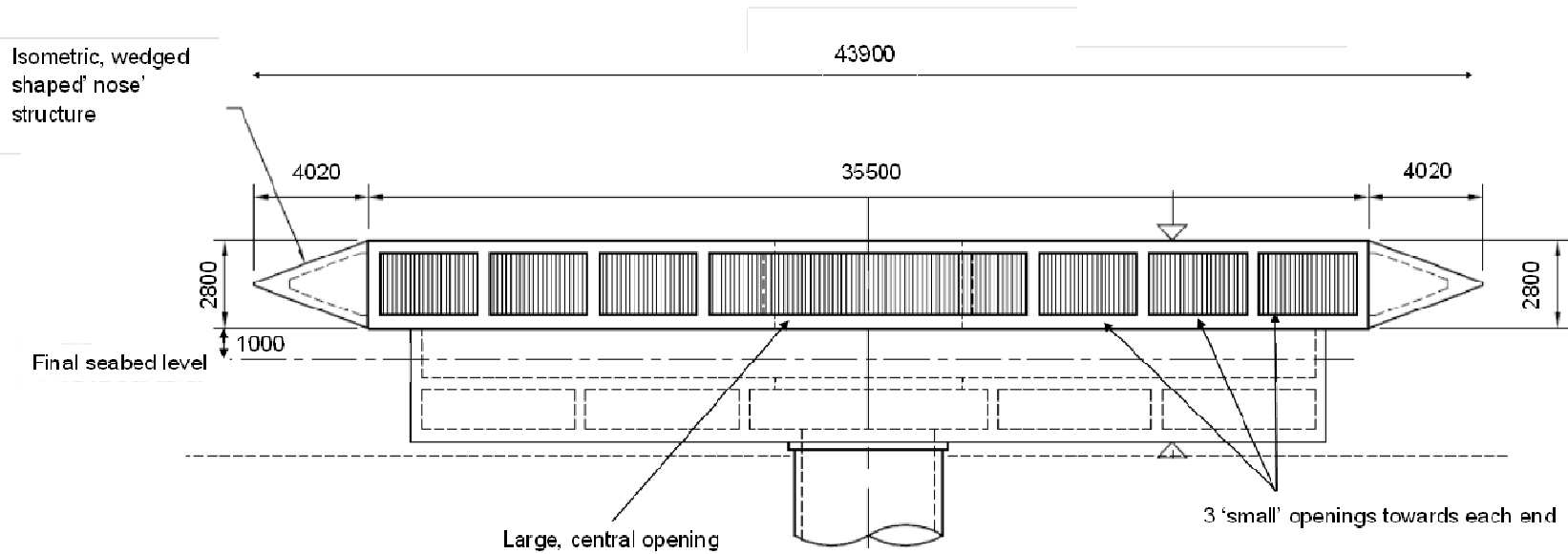

Figure 6: Side view of low velocity, side-entry intake head

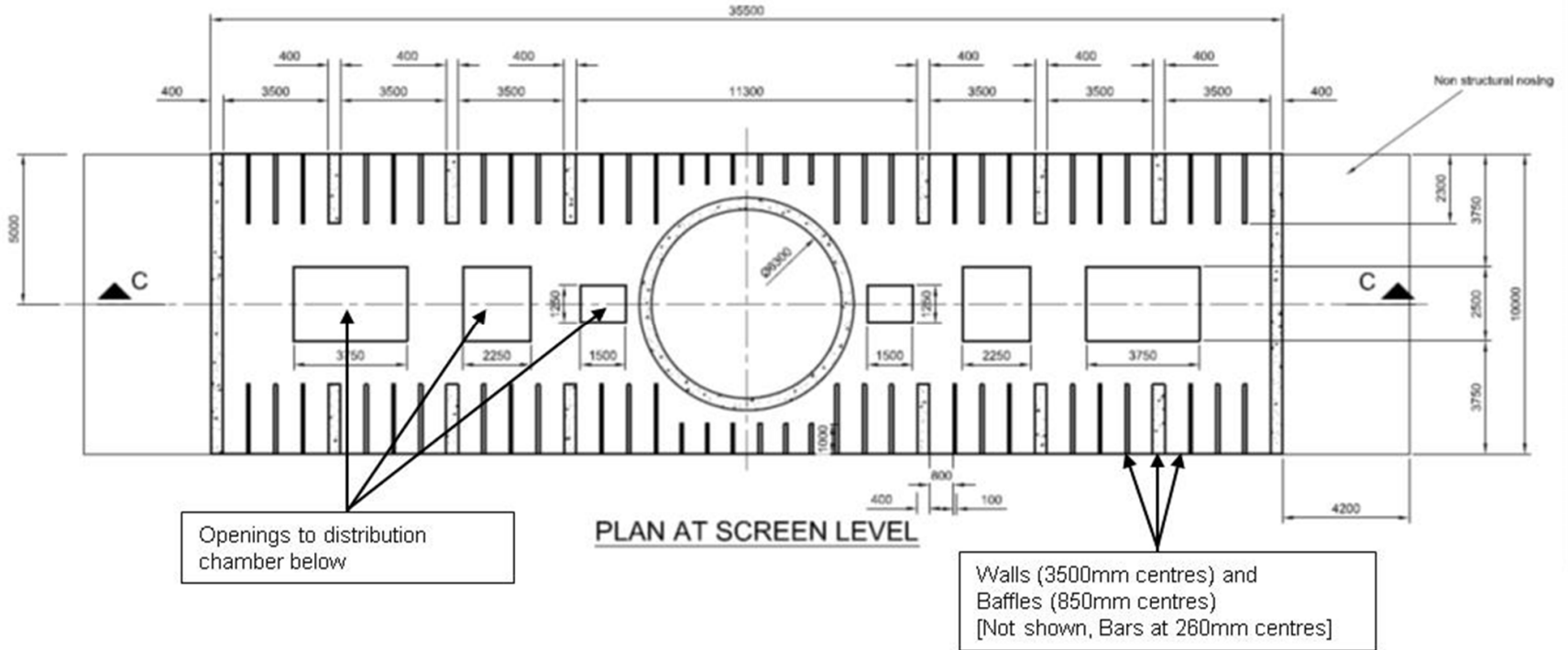

Figure 7: Plan view of low velocity, side-entry intake head

4.4 Intake Shafts

- 4.4.1 Each intake head linked to the intake tunnel by a vertical shaft. Each shaft will be approximately 30 m deep, the precise depth will be determined by site specific bathymetry and geology. Each shaft will be 4.6 m diameter.
- 4.4.2 The shafts will be lined with pre-fabricated concrete segments; as they segments are moulded, they will have a very smooth finish.

4.5 Intake Tunnels

- 4.5.1 The offshore intakes are linked to the station onshore by large tunnels. As explained in section 4.1, each Unit has its own, separate intake tunnel to which 2 offshore intakes are connected (see Figure 3).
- 4.5.2 The length of the Unit 1 intake tunnel is approximately 3845 m and the length of the Unit 2 tunnel is approximately 3390 m. The length of the tunnels is dictated by the locations of the intake and outfall heads – this information is presented in section 4.1
- 4.5.3 For each tunnel, one intake shaft is connected at the very end the tunnel and the other is connected approximately 200 m landward along the tunnel. This duplication is to provide redundancy should one of the intake heads become unavailable.
- 4.5.4 The horizontal alignment of the two intake tunnels is undergoing detailed assessment for construction purposes and may change slightly from those illustrated in the Development Consent Order application, whereby the curves at the more landward end follow slightly different, more easterly paths before re-aligning with the original, DCO profile. The intake locations are fixed so, for the avoidance of doubt, this re-alignment does not alter the intake locations nor the associated impact assessments.
- 4.5.5 Both intake tunnels will have similar vertical profiles. Each tunnel will exit its respective forebay and pass under the sea wall at a depth of approximately -15.50 m ODN. The tunnels then descend at an angle of approximately -8% to a depth of approximately -40.70 m ODN, before rising at an incline of approximately 0.1% out towards the intake shafts, which they join at a depth of approximately -39.0 m ODN (-39.1m ODN for the southern outfall shafts and -38.9 m ODN for the northern outfall shafts).
- 4.5.6 The horizontal profiles of the intakes tunnels confirmed to date (notwithstanding what is said at Section 4.5.4) are shown in Figure 8 (and at A3 in Appendix B).
- 4.5.7 The vertical profiles of the intakes tunnels for Units 1 and 2 are shown in Figures 9 and 10, respectively (and at A3 in Appendix B).
- 4.5.8 Each tunnel will have a finished internal diameter of 6 m.
- 4.5.9 The tunnels will be bored using earth pressure balance-type tunnel boring machines (TBM) then lined with reinforced, precast concrete segments, fitted with water proofing gaskets. Because the segments are moulded, they will have a very smooth finish.
- 4.5.10 Under normal operational conditions, water will flow at approximately 2.3 m s^{-1} along the tunnel.

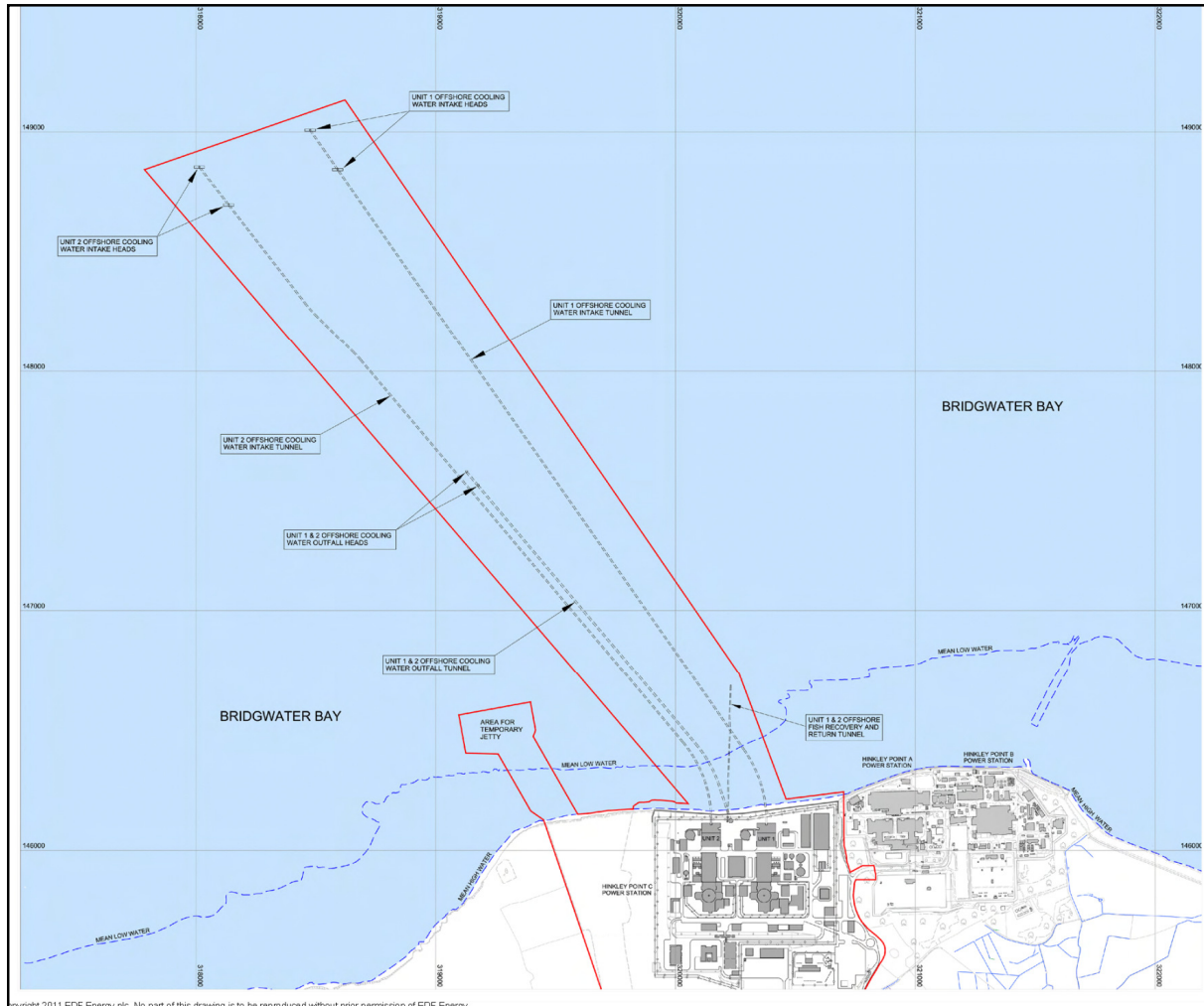

Figure 8: Horizontal profiles for the intake tunnels

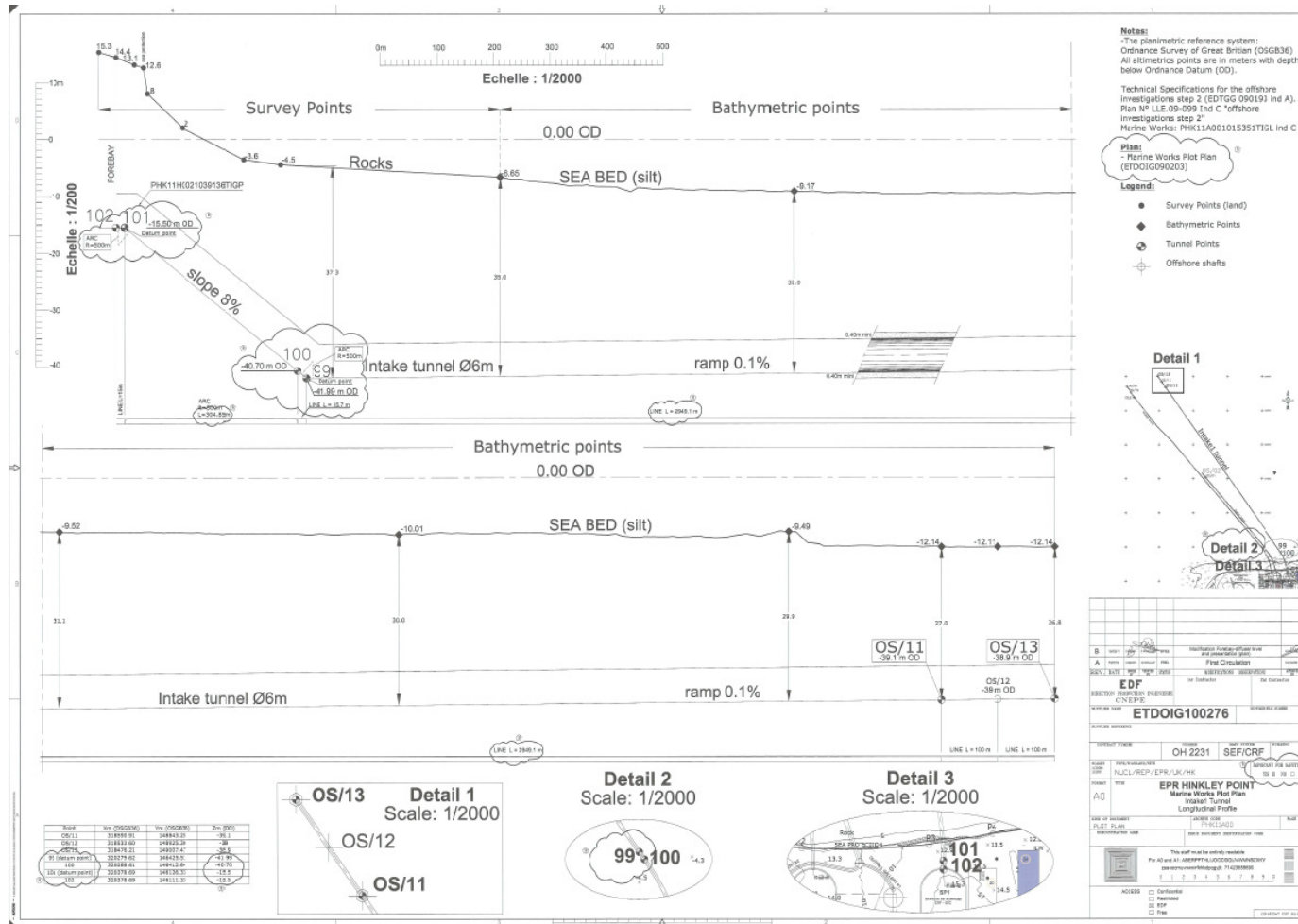

Figure 9: Vertical profile for the intake tunnel to Unit 1

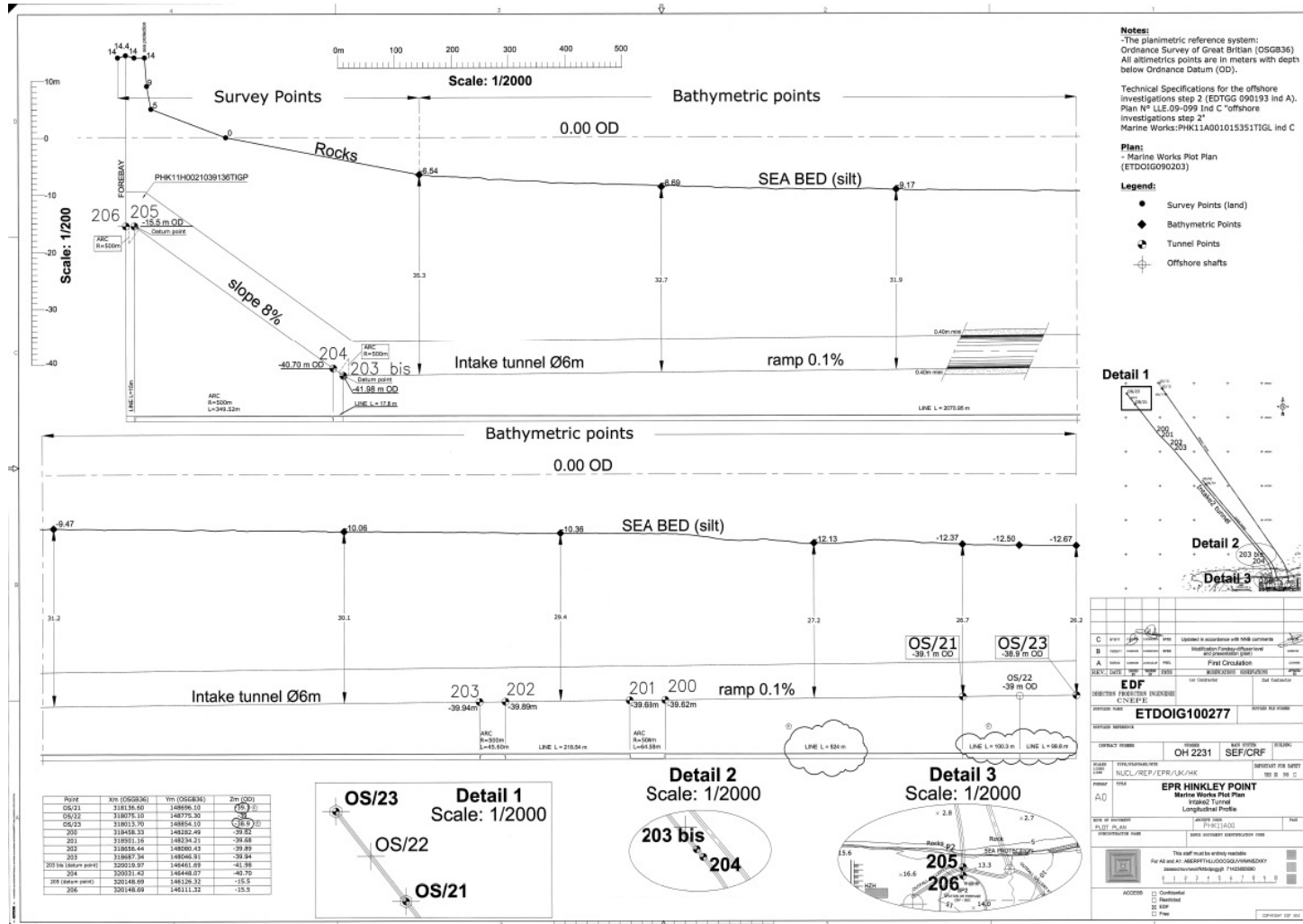

Figure 10: Vertical profile for the intake tunnel to Unit 2

5 FOREBAY (HPF)

- 5.1.1 At its landward end, each intake tunnel terminates at the forebay (HPF). The forebay (HPF) is a large volume structure that serves to dissipate the hydraulic energy from the water exiting the intake tunnel before it enters the cooling water pump house (HP) (where the large pumps that pump the water through the cooling water system are situated). This is necessary to limit turbulence from the flow so that the water enters the cooling water pump house (HP), and to allow a smooth distribution of flow into the different water channels.
- 5.1.2 The design of the Hinkley Point C forebay (HPF) has had to be modified from that described in the Development Consent Order (DCO) due to site specific environmental constraints. The original forebay (HPF) had the flexibility to either semi-circular or rectangular within the DCO parameter approved in March 2103. A non-material change application was approved in September 2015 which increased the width of the forebay (HPF) but retained these shape parameters. The original forebay (HPF) design was a semi-circular structure, with internal baffles to dissipate hydraulic energy, however, detailed analysis of the hydraulics and sediment loading of the Bristol Channel showed that there would be significant sedimentation within the forebay (HPF). The design was, therefore, changed to a Blayais-style⁶ forebay.
- 5.1.3 The Hinkley Point C forebay (HPF) design is essentially a deep, rectangular structure. It will comprise a surge chamber that accommodates the incoming cooling water during normal, operational pumping and an expansion chamber to accommodate any transient surges from pump trips etc. The dimensions are as follows (see also Figures 11 and 12):
- (a) the surge chamber will be 19 m long and 30 m deep;
 - (b) the expansion chamber, located above the surge chamber, will be 4 m deep and 31 m long;
 - (c) both chambers will have a total width of 60 m, although a wall will separate them into two halves (one half supplying each of the 2 drum screens in the cooling water pump house (HP); see Section 6.3);
- 5.1.4 Because the forebay (HPF) surge chamber is split into two halves, the intake tunnel splits into two 'forks' (each of 4.6 m diameter) to supply them (Figure 12). Above the point where the tunnel splits there is a vertical access shaft to allow isolation of half of the forebay (HPF) for maintenance purposes.
- 5.1.5 The incoming seawater enters the forebay (HPF) at base level in the surge chamber, at a velocity of approximately 2.0 m s^{-1} .
- 5.1.6 Once in the surge chamber, water flows left or right to supply the four trains of the drum screen. On the outer side of each surge chamber there is also a single train to supply the band screen (Figures 11 and 12). The trains leading to the drum screens are 6.5 m high by 3.5 m wide (2 water channel each side of the drum screen), and the trains leading to the band screens are 6.5 m high by 2.0 m wide.
- 5.1.7 The flow velocity in the concrete gallery linking the forebay to the band screen train of the cooling water pump house is 2 m s^{-1} at Mean Sea Level (MSL) under normal conditions.

⁶ Blayais is an EDF nuclear power station on the banks of the Gironde estuary in western France.

5.1.8 The flow velocity in the concrete gallery linking the forebay to the drum screen train of the cooling water pump house is 2 m s^{-1} at Mean Sea Level (MSL) under normal conditions.

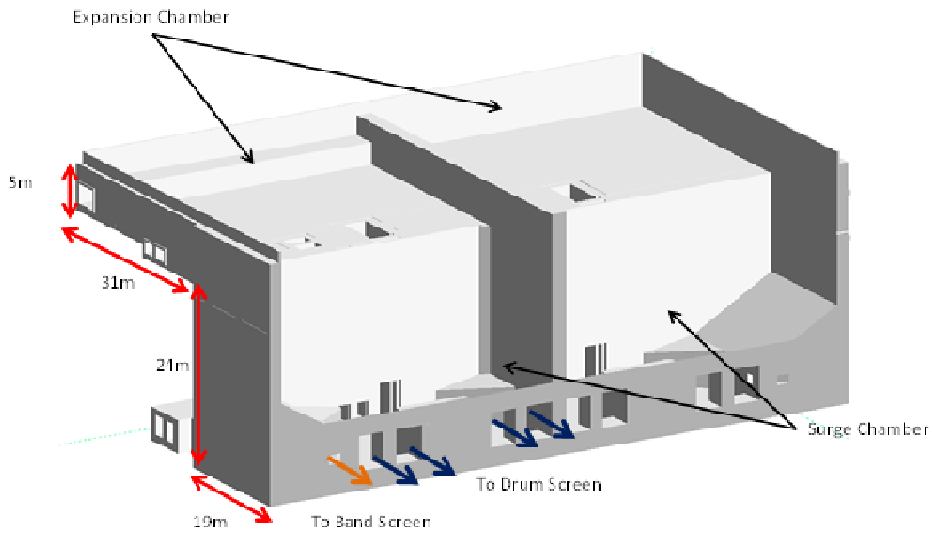

Figure 11: Hinkley Point C Forebay Design (looking seaward))

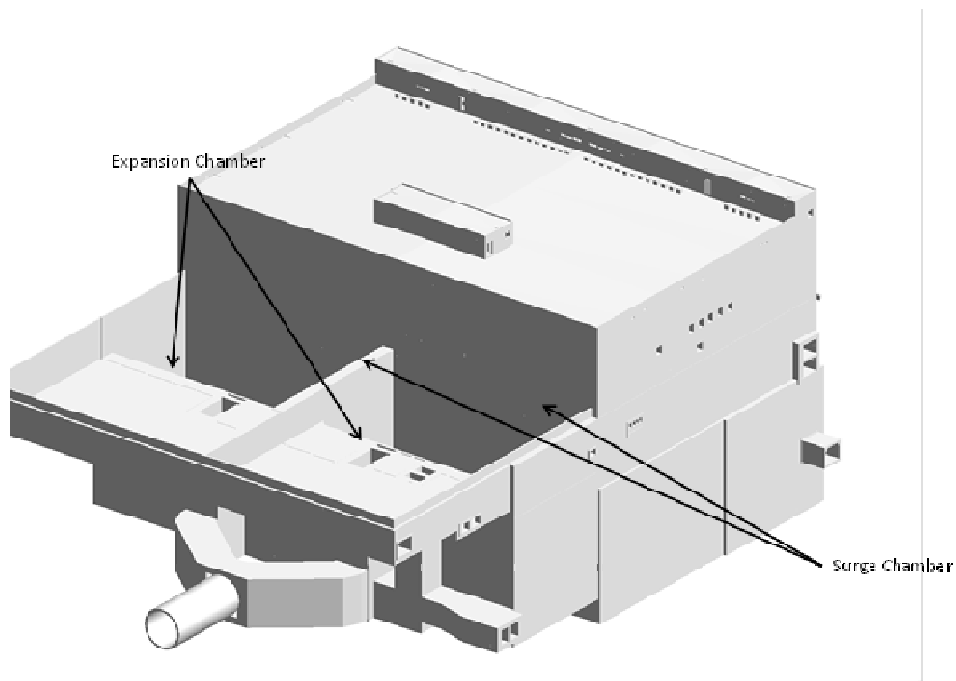

Figure 12: Hinkley Point C Forebay Design (looking landward))

6 COOLING WATER PUMP HOUSE (HP)

6.1 Debris (Trash) Racks and Rakes (SEF)

- 6.1.1 Water exits the forebay (HPF) surge chamber and enters the cooling water pump house (HP) through 10 water channels: one channel for each of the two lateral trains (one train leading to each of the two band screens) and four water channels for each of the central trains (one train leading to each of the two drum screens).
- 6.1.2 Before the water enters these screens it is passed through a debris (trash) rack (SEF system), which filters large pieces of debris from the cooling water that could otherwise potentially damage the fine mesh of the drum and band screens. There is a separate rack and raking system on each band screen train and four rack and raking systems on each drum screen train, giving 10 systems in total per Unit. The racks and rakes are also referred to as 'coarse filtration'. See Ref [6].
- 6.1.3 Velocity through the band screen channel trash rack under normal operating conditions is 0.23 m s^{-1} at Mean Sea Level (MSL). It can vary between 0.2 and 0.3 m s^{-1} with the tide.
- 6.1.4 Velocity through the drum screen channel trash rack under normal operating conditions is 0.36 m s^{-1} at Mean Sea Level (MSL). It can vary between 0.3 and 0.4 m s^{-1} with the tide.
- 6.1.5 Upstream of each debris (trash) rack is a sluice gate to allow isolation of the relevant channel.
- 6.1.6 The debris (trash) rack has vertical bars that extend from the bottom level of the water channel up to 6.5 m. The width of debris (trash) rack channel is 3.5 m for the drum screens and 2.00 m for the band screens). The bars will be 10 mm wide and 70 mm deep (10 mm facing the flow). The bars will be made of austenitic-ferritic, stainless steel (super duplex) or similar, suitable material.
- 6.1.7 Debris trapped on the rack is cleared periodically by a moving rake. Routine raking frequency is not yet determined, but could be 3 or 4 times per day, controlled by a timer. Raking will also be triggered, should significant clogging of the rack occur, when the raking screen differential exceeds 50 mm above normal.
- 6.1.8 The rake itself consists of a 'skip' (or bucket) which passes from the bottom to the top of the rack, by means of a hoist system with hydraulic power pack, collecting material impinged on the rack as it does.
- 6.1.9 The skips are scaled according to which fine filtration unit they protect. The skips protecting the drum screens will be 3.5 m long, whereas the skips protecting the band screens will be 2.0 m long. Skips will be of similar width and depth, ca. 386 mm and 168 mm, respectively. Total width of the skip, including the tines, will be approximately 569 mm (see Figure 13).

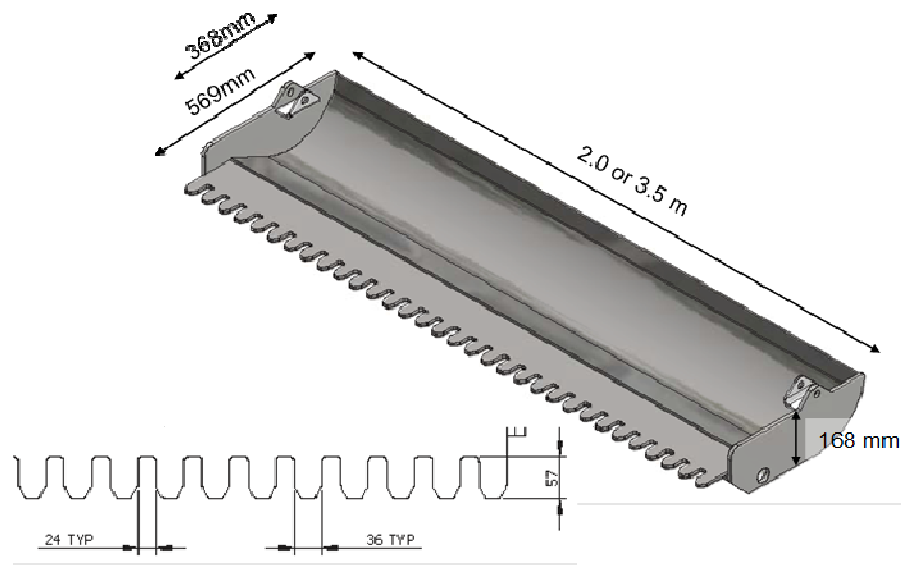
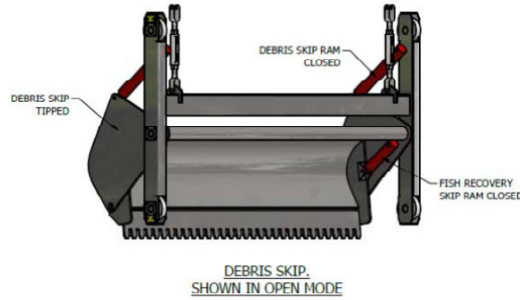
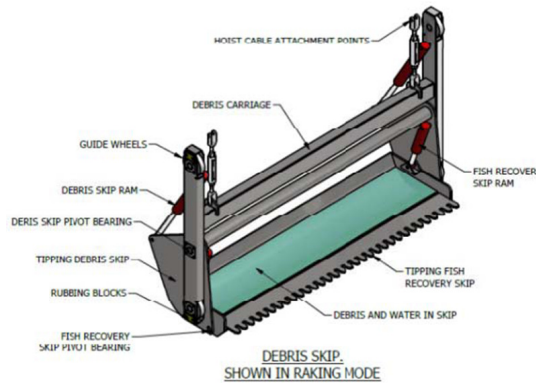

Figure 13: Skip design and dimensions

- 6.1.10 The skips are trough shaped so that they collect and retain water along with the debris and fish. For the drum screens, the large skip capacity is 58 l whereas, for the band screens, the small skip capacity is 33 l. Water depth retained in the trough will be approximately 78 mm for both types of skip.
- 6.1.11 The skip has tines, angled upwards, on its leading edge to facilitate removal of debris from the rack bars. The tines are 57 mm long, 36 mm wide and have a gap of 24 mm between them (typical dimensions, within manufacturing tolerances).
- 6.1.12 As the rake rises, the skip collects material impinged on the rack collecting. When the rake reaches the top of the rack, the skip continues upwards in mid-air for a further 16 m (approximately) until it reaches deck level. Here, the skip is tipped to allow water, debris and any impinged fish to discharge into the collection gutter, before a scraper scrapes out any trapped debris. Hydraulic rams perform the tipping motion of the skip. See Figures 14 and 15.
- 6.1.13 The skip discharges directly into a collection gutter (launder) which runs parallel to the raking system for transfer of the debris and fish to the filtering debris recovery pit (HCB). The drop height, dictated by the slope of the gutter across the ca. 80 m width of the cooling water pump house, will be approximately 500 mm.
- 6.1.14 The rake will travel at different speeds for different parts of the cleaning cycle:
 - (a) Hoisting speed is 7.5 m min^{-1} ;
 - (b) Lowering speed is 15 m min^{-1} ;
- 6.1.15 One full cleaning cycle takes approximately 5 minutes.



Stage 1: The skip is left in 'open mode' (i.e. with the skip pulled back away from the rack bars) as it makes the descending part of the raking cycle.



Stage 2: At the bottom of the descent, a hydraulic ram extends to push the skip into 'closed mode' so that the skip is against the rack bars. The skip is then hoisted upwards, along the rack bars initially and then in free form, collecting debris and fish that are impinged on the bars.

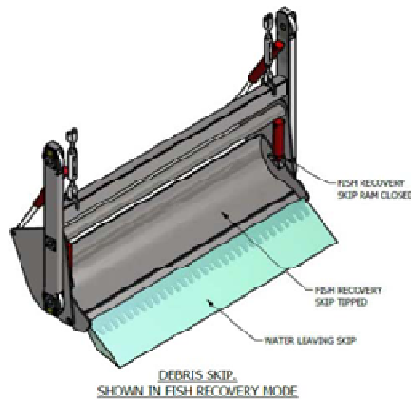

Stage 3: Once the skip reaches the top of the hoist, a hydraulic ram tips the skip so that water, fish and debris flow out of the skip and into a collection gutter (launder) at deck level. Finally another hydraulic mechanism pushes a scraper across the skip to push out any debris that does not flow out under gravity.

Figure 14: Trash / debris rake operating cycle

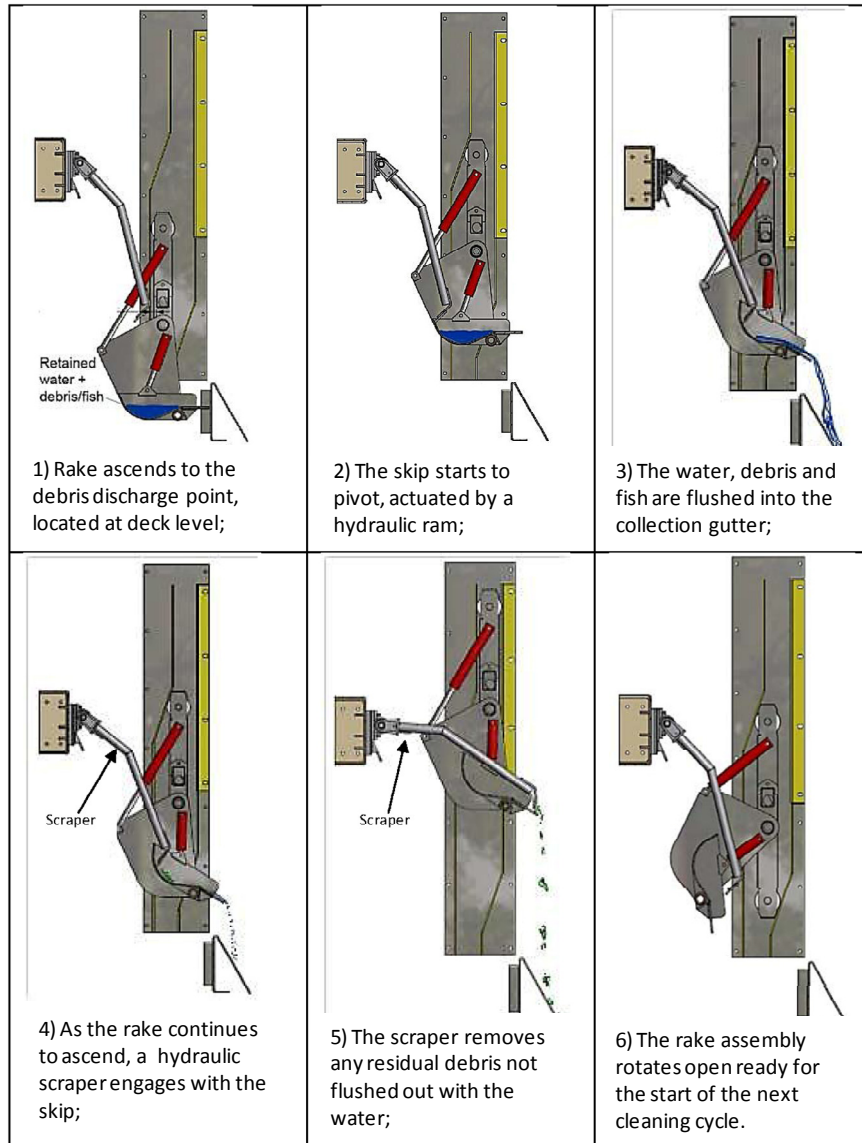

Figure 15: Detailed view and description of the discharge mechanism

6.2 Band Screens (CFI)

6.2.1 Hinkley Point C will have two types of ‘fine filtration’ (CFI system): band screens and drum screens. These are located in the cooling water pump house (HP building). The drum screens filter water that mostly to supply the main cooling water system (CRF system) (but also the essential service water and ultimate cooling water systems; SEC and SRU, respectively), and the band screens filter water that serves the service and safety cooling water systems (the auxiliary cooling water, essential service water and ultimate cooling water systems; SEN, SEC and SRU, respectively).

6.2.2 The band screens are nuclear safety classified. They are seismically qualified and qualified to withstand air plane crash (APC qualified).

- 6.2.3 As described in Section 5.1.6 and shown in Figure 12, 1 train (split into 4 channels) goes to each drum screen and 1 train (single channel) goes to each band screen, but the band screens receive only a small fraction of the total cooling water exiting the forebay. The volume of water passing through the band screens will depend upon tidal conditions, but will not exceed 9% of the total cooling water flow. This equates to a total of $11.25 \text{ m}^3 \text{ s}^{-1}$ ($2.81 \text{ m}^3 \text{ s}^{-1}$ for each band screen) based on the 'average' total flow of $125 \text{ m}^3 \text{ s}^{-1}$ for both Units. The maximum flow through a single band screen will be $3.7 \text{ m}^3 \text{ s}^{-1}$ (during high water on the highest tides).
- 6.2.4 As its name suggests, the band screen comprises a continuous 'band' of fine filtration mesh which travels in a conveyor-like motion around a spindle at the top and bottom of the band. The mesh at Hinkley Point C will be made from stainless steel and will have a mesh size of $5 \text{ mm} \times 5 \text{ mm}$. See Ref [7].
- 6.2.5 For Hinkley Point C, the band screen will be of the 'dual-flow' screen type (See Figure 16). This means that the band screen is orientated parallel to the flow and the water passes from the outside though both the ascending and descending sides of the band into the inside of the band, before the filtered water exits the band screen well via a conduit at the rear of the screen called the 'suction eye'. The dual-flow type of band screen is essential on a nuclear power station as it prevents debris from being carried over to the filtered, exit chamber.

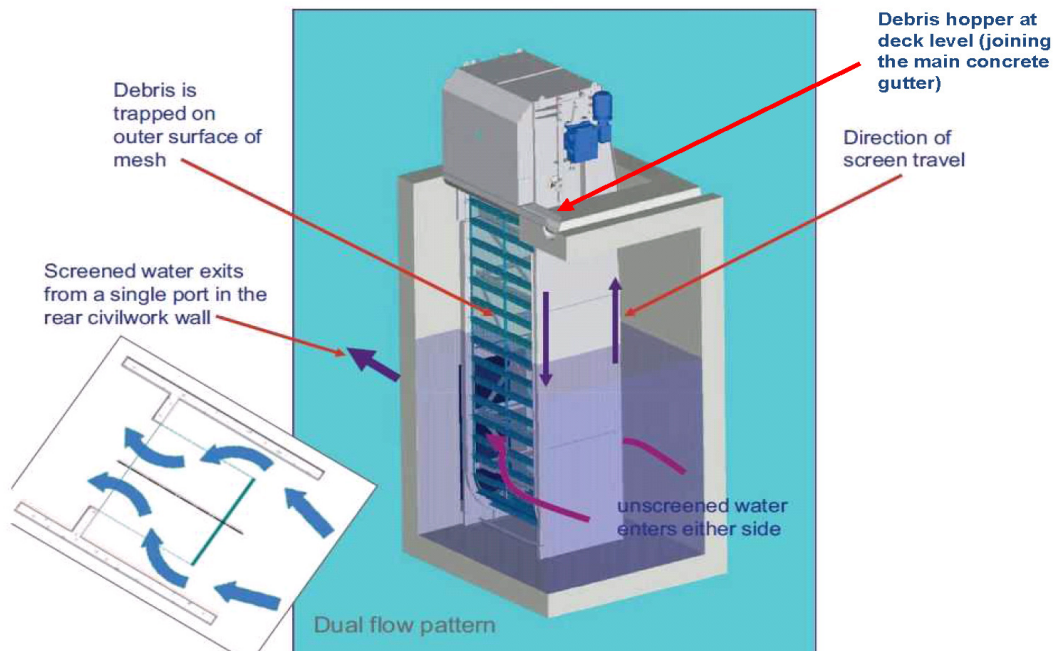

Figure 16: Dual-flow Band Screen design

- 6.2.6 The band screens will be approximately 25 m high and 2.5 m wide

- 6.2.7 The very large size of the band screens is due to the very large tidal range at Hinkley Point, where there is 13.21 m between the highest and lowest tides⁷. The band screen size needs to be large enough to accommodate water levels at all stages of the tide but, in fact, the tidal range experienced in the cooling water pump house (HP) itself is 3.7 m greater at the very lowest tide due to head loss in the system. The tidal range experienced within the cooling water pump house (HP) is 16.91 m, with HAT = +7.12 m ODN and LAT = - 9.08 m (- 6.09 m tidal level minus 3.7 m head loss). The system also has to be able to withstand 'extreme' water levels defined on a return period basis of 10 000 year with consideration of tidal and storm surges and climate change related sea level rise (extreme high water level (EHWL) at Hinkley Point is +9.73 m ODN).
- 6.2.8 Average velocities through the band screen filtering surface were provided in a dedicated report (Ref [7]):
- (i) Highest Astronomical Tide (HAT): 0.05 m s⁻¹
 - (ii) Mean Sea Level (MSL): 0.06 m s⁻¹
 - (iii) Lowest Astronomical Tide (LAT): 0.16 m s⁻¹
- It should be made clear that these values are averages, calculated by dividing the flow rate across the whole surface area of the screen. In reality there is a much greater flow at the bottom of the screen where flow is greatest near to the suction eye. At the suction eye, the flow is closer to 1 m s⁻¹, equating to 0.5 m s⁻¹ cross the screen in this area (flow is via both sides of the screen, hence halving the value).
- 6.2.9 The band screens run in guides mounted vertically in the chamber walls. Rotation is achieved by the motor unit housed in the head frame, which sits directly above the band screen at deck level (10.80 m ODN). The head frame houses a chain and gear to rotate the screen which is powered by electrical motors (different motors allow for different rotation speeds). The guides also provide a seal which prevent unfiltered water and debris larger than the filtration threshold from bypassing the band screens.
- 6.2.10 The band screen will be able to rotate at 3 different speeds: the 'usual' High and Low Speeds and also a Very Low (a continuous 'creep') Speed specifically to enable fish protection. High speed and Low speeds are 10 m min⁻¹ and 2.5 m min⁻¹, respectively, and will operate according to clogging as triggered by the detection of a pressure differential across the screen until the clogging is clear. Very Low Speed is 0.5 m min⁻¹ and the screens will travel at this speed continuously so that impinged fish are continuously recovered from the screen (instead of being impinged until the next rotation is triggered, as would normally happen). Very Low Speed is not a standard operational speed for band screens but has been incorporated to allow the screen to be operated continuously to enable fish recovery; continuous operation at Low Speed would cause excessive wear of the screens motor chains (this is true for all metal screens available and referred to in Ref [3]).
- 6.2.11 Due to the large size of the bandscreens, the time for the screen to do one complete rotation can vary significantly depending on operation speed. Times for one complete rotation are approximately 5, 20 and 100 minutes for High, Low and Very Low speeds, respectively.
- 6.2.12 The band screens are fitted with buckets for the safe recovery of fish from the screens. Buckets are fitted at approximately 600 mm intervals. Each bucket will retain approximately 40 l of water,

⁷ Highest astronomical tide (HAT) is +7.12 m ODN and lowest astronomical tide (LAT) is -6.09 m ODN

equating to an approximate depth of 90 mm once the screen emerges from the water as it ascends towards the top of the screen.

- 6.2.13 The buckets will be approximately 523 mm wide and approximately 2.5 m long (i.e. the full width of the band screen). Depth varies with the profile of the bucket, but will be around 100 mm.
- 6.2.14 The basic bucket profile can be seen in Figure 17. As can be seen, the bucket has curves over to help prevent more active fish species from flipping out of the bucket.
- 6.2.15 As the band screen buckets exit the water vertically, water level retained in the bucket is constant irrespective of tide level.
- 6.2.16 Washer sprays in the head frame are used to flush debris and fish from the mesh and buckets and into collection gutters (launders). Three types of washer spray that vary in spray pressure are fitted: High, Low and Very Low Pressure sprays are 6.5 bar, 3.5 bar and 1 bar, respectively. The Very Low Pressure spray is used specifically, and in isolation, to flush fish from the hoppers as higher pressures might damage the fish.



Figure 17: Basic band screen bucket in profile

- 6.2.17 Once the bucket gets to deck level, they continue over the apex of the band screen before discharging their contents into the collection gutter under gravity. The discharge sequence is shown in detail in Figure 18.
 - (i) As the bucket reaches the very top of the band, and so arches over from horizontal to perpendicular, water flows downwards under gravity and drains through the mesh of the screen;
 - (ii) As the bucket continues over the top of the band, the upper exterior Very Low Pressure sprays flush the fish out of the bucket and across the screen. As the bucket continues the interior Very Low Pressure sprays spraying through the mesh, and the lower exterior Very Low Pressure spray, flushes the fish and debris off the mesh so that they discharge, under gravity, into the

upper collection gutter (see Figure 18). The free drop from the screen mesh into the collection gutter is approximately 500 mm.

- (iii) As the screen continues to rotate, any debris stuck on the mesh panel (for example, seaweed) is flushed off by the Low Pressure spray (or High Pressure spray under a severe clogging scenario) into the lower collection gutter.

6.2.18 Approximately $56 \text{ m}^3 \text{ h}^{-1}$ of the water retained in the buckets and the flushing sprays (approximately 34%) reaches the collection gutter, with an additional $37.5 \text{ m}^3 \text{ h}^{-1}$ provided by an additional sparge (or flushing) pipe. This sparge supplements the flushing flow in the gutter as much of the water retained in the bucket drains back into the well through the mesh screen as the bucket tips.

6.2.19 As explained above, there are two separate collection gutters. The upper gutter collects fish and debris washed out of the buckets, and the lower gutter collects debris washed off by the Low (or High) Pressure spray. Both these gutters feed into the common gutter that transfers fish and debris to the filtering debris recovery pit (HCB) (see Sections 6.4 and 7).

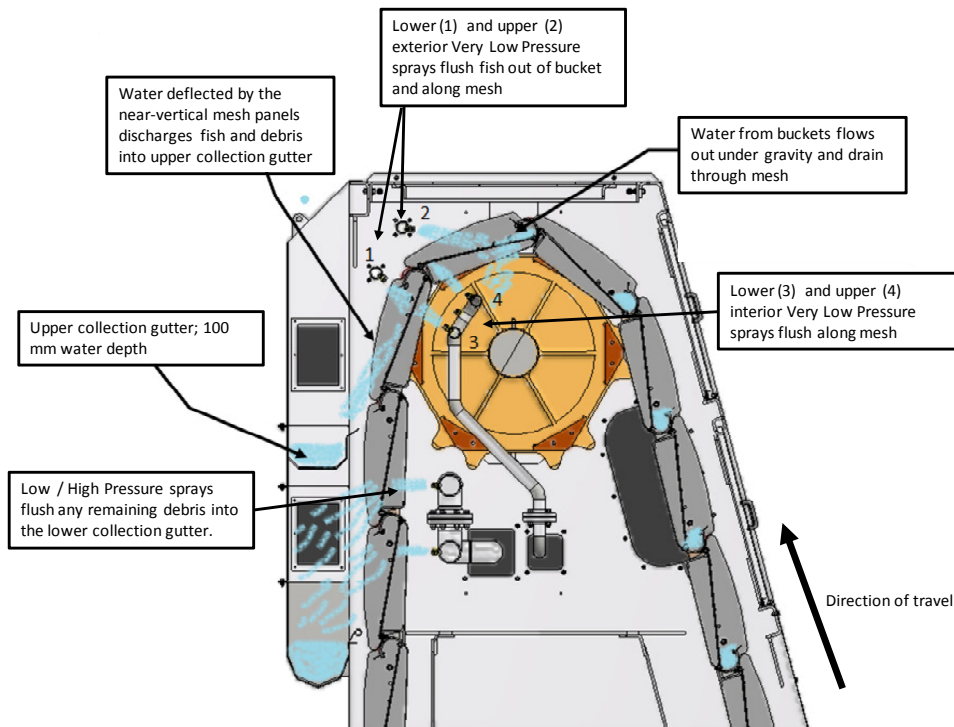

Figure 18: Detailed section of band screen head frame showing flushing and discharge of collected material.

6.3 Drum Screens (CFI)

6.3.1 The other type of fine filtration (CFI system) is the drum screens. Each Unit will have two drum screens, fed by 2 trains exiting the forebay (HPF) (each train is split into 4 (see Section 5.1.6) and passes through a coarse filtration debris rack; see Section 6.1). The drum screens filter water that supplies the main cooling water system (CRF system) and also the essential service water and ultimate cooling water systems (SEC and SRU, respectively)) and so filter the vast majority of the total volume of water exiting the forebay (HPF) (>90%).

- 6.3.2 As with the band screens, the drum screens are safety classified structures; this means they have to be able to withstand earthquakes. The drum screens are not required to withstand an airplane crash (APC).
- 6.3.3 The drum screens consist of a large rotating cylindrical structure with mesh filtration panels attached to the periphery. The mesh panels are the same specification as these on the band screens: mesh size = 5 mm × 5 mm and made of stainless steel. See Ref [8].
- 6.3.4 The drum screens will be able to rotate at 3 different speeds, depending on the degree of headloss (indicative of debris loading). The lowest operational elevation rate (speed) will be 2.5 m min^{-1} , and this will be the normal operational speed. Under increased debris clogging scenarios, the rotation speed can be increased to high (10 m min^{-1}) and very high speeds (20 m min^{-1}) in order to clear the debris more quickly.
- 6.3.5 Like the band screens (see section 6.2.7), the drum screens also need to accommodate the whole range of potential water levels for the large tidal range encountered at Hinkley Point. Because of this, the drum screens at Hinkley Point C will be the largest of their kind in the world, measuring 27 m diameter and 6.65 m wide; each screen will have a mass of approximately 80 t.
- 6.3.6 The centre of each drum screen is mounted at -1.48 m ODN, with the bottom and top at -14.98m ODN and +12.02m ODN respectively.
- 6.3.7 The Hinkley Point C drum screens are of typical double-entry, 'in-to-out' design. This means that they receive water from both sides, which flows into the centre of the drum and then out through the mesh filtration panels (see Figure 19). As the water passes through the mesh panels, debris (and fish) are impinged on the mesh and, as the drum rotates, are lifted out of the water up to deck level where they are flushed out into collection "hoppers" (large troughs).
- 6.3.8 To improve fish protection, the drum screen has one collection bucket mounted at the junction of every radial spoke of the drum (where spokes join the drum there is a cross member that joins the spokes on opposite sides of the drum, the cross members create a ledge which often partially traps fish before they drop back in to the drum screen well). This gives a total of 56 collection buckets on each side of the drum screen.
- 6.3.9 Flow velocities entering the drum screen (on both sides) is 0.50 m s^{-1} under normal conditions.
- 6.3.10 The drum screen bucket details are shown on Figure 20.

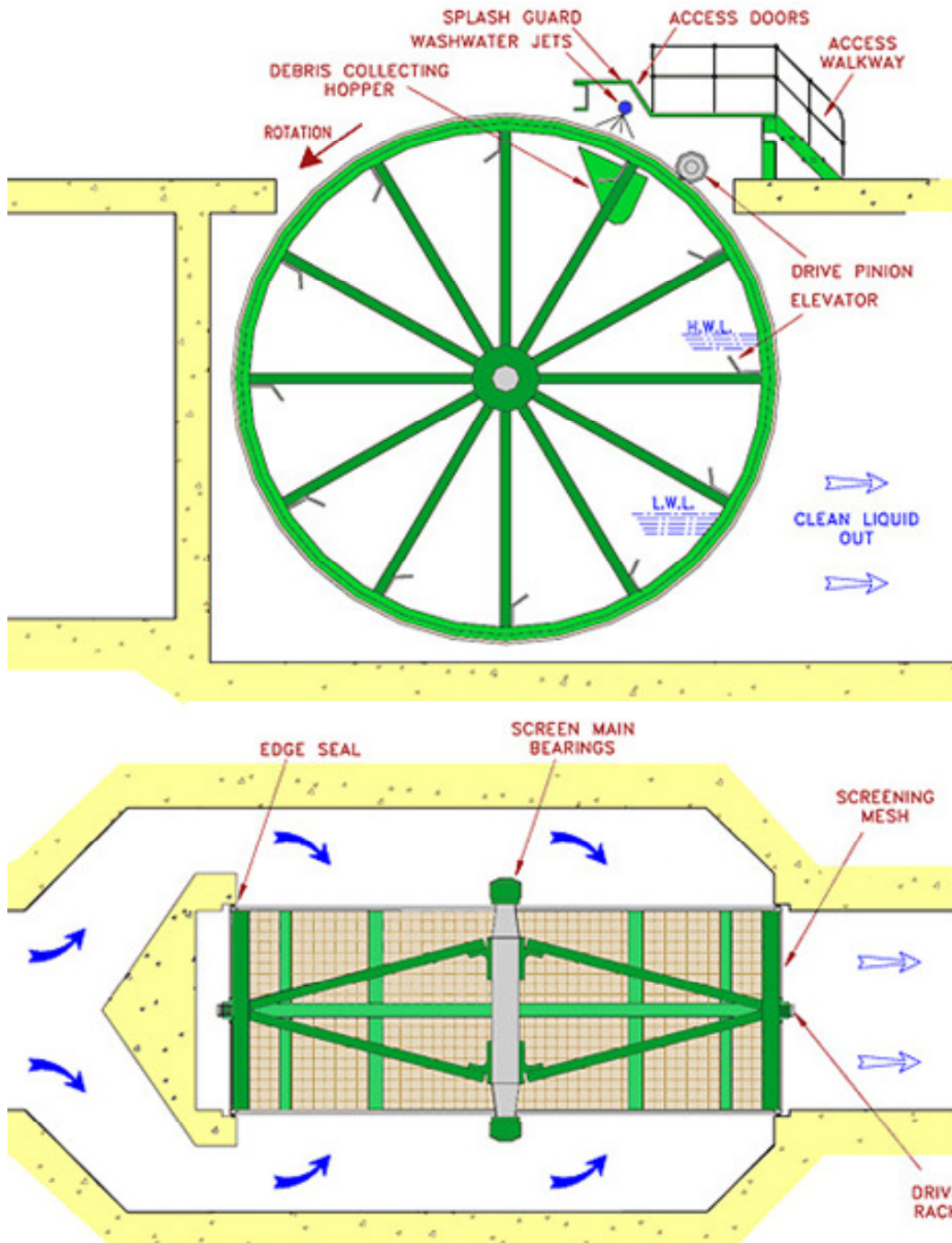

Figure 19: Double-entry, 'in-to-out' drum screen

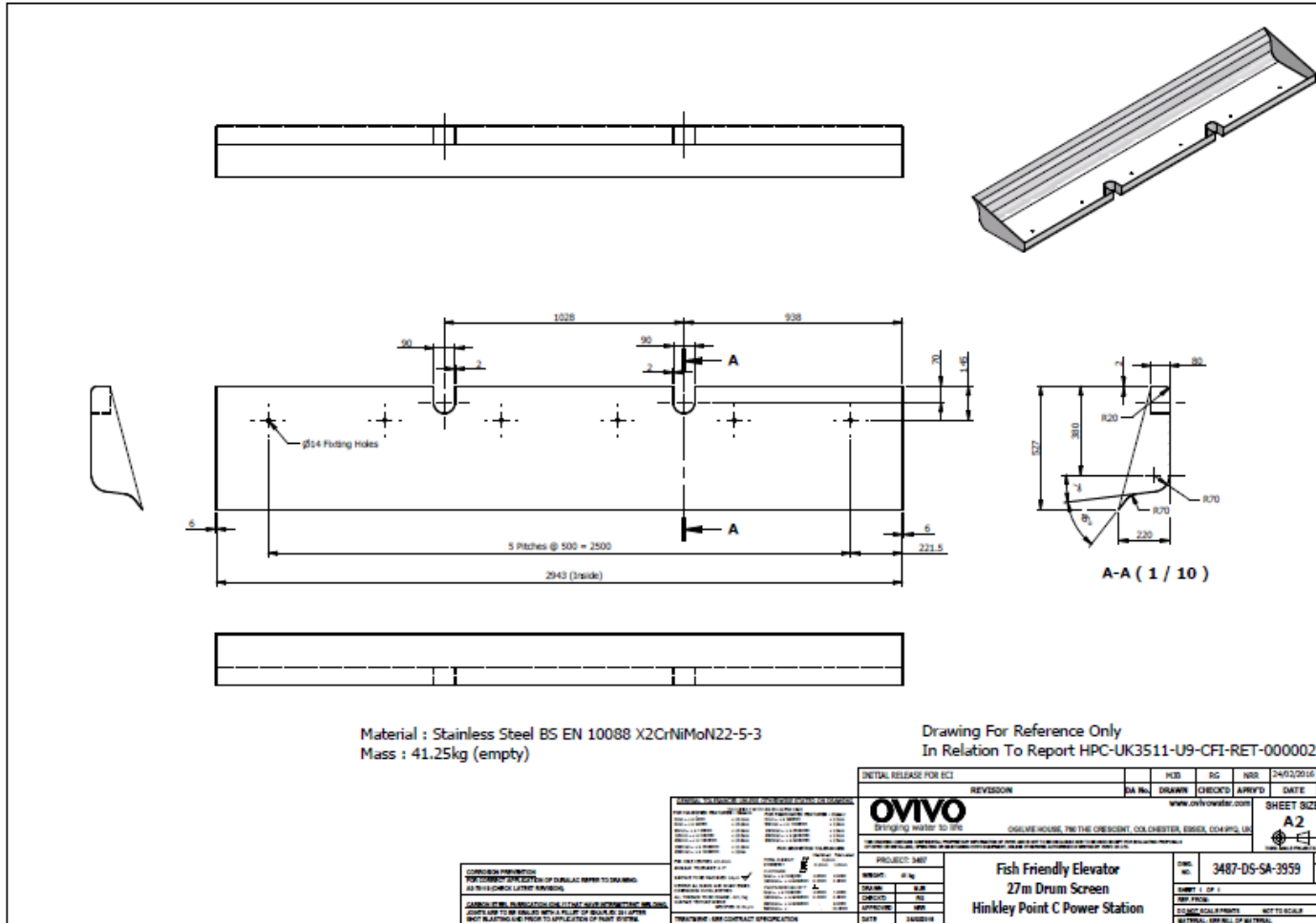

Figure 20: Drum screen bucket design detail

- 6.3.11 As the drum screens are round, and the water level in the cooling water pump house varies according to tidal level, the volume of water retained in the buckets will vary according to tidal level in the estuary. Water is retained in the bucket as the bucket exits the water; because the drum screen is round the bucket will exit the water at different angles depending on the tide level (see Figure 21).
- 6.3.12 Similarly, as the water level in the cooling water pump house varies due to tidal level in the estuary, the transit time from emergence from the water until the drum screen rotates the bucket around to the wash water sprays and collection hoppers varies (being longest at Lowest Astronomical Tide (LAT) and shortest at Highest Astronomical Tide (HAT). See Ref [8].
- 6.3.13 When the bucket leaves the water at Lowest Astronomical Tide (LAT), the bucket points upwards at an angle of approximately 40° (see Figure 21 (top)).
- 6.3.14 At this point the bucket will retain 9 litres of water with a depth of 48 mm and will travel 26.2 m taking 8 minutes to reach the start of the hopper collection phase. When the bucket reaches the true horizontal position this volume of water will disperse across the bucket to a depth of 7.5 mm. As the bucket transcends to the collection hopper 14% of this volume will be lost as the changing bucket approach geometry releases water.
- 6.3.15 When the bucket leaves the water in a horizontal position (mid-tide level), the bucket will retain 99 litres of water filling the bucket to its maximum depth of 78 mm and will travel 15.8 m taking 4.8 minutes to reach the start of the hopper collection phase. As the bucket transcends to the collection hopper 92% of this volume will be lost as bucket releases water (see Figure 21 (middle)).
- 6.3.16 When the bucket leaves the water at Highest Astronomical Tide (HAT), each bucket will be pointing downwards at approximately 40° (see Figure 19 (bottom)). Each bucket will retain 34.25 litres of water with an effective depth of 81mm and will travel 5.46m taking 1.65 minutes to reach the start of the hopper collection phase. As the bucket transcends to the collection hopper 77% of this volume will be lost as bucket releases water (see Figure 21 (bottom)).
- 6.3.17 The loss of water due to the rotation geometry of the drum screen and tidal range at Hinkley Point cannot be mitigated by altering the bucket design. Re-shaping the bucket to ensure retention of more water would mean that the bucket would not flush efficiently at the top of the cycle, potentially leaving fish and water in the bucket until they reach the high-pressure sprays.
- 6.3.18 The HPC screen supplier, Ovivo, is the market leader and will apply learning for other sites (e.g. Pembroke and Longannet, both of which use Ovivo screens) to ensure optimum bucket design for fish species and conditions encountered at HPC.
- 6.3.19 As with the band screens, the drum screens are equipped with sprays to wash the debris and fish out of the buckets and off the screens. Again, different pressures are used for flushing debris and fish: a Very Low Pressure spray (1 Bar) is used to flush the fish from the buckets and Low Pressure (3 bar) and High Pressure (6.5 bar) sprays are used to wash other debris from the screen.
- 6.3.20 The spray and hopper assembly is repeated on both halves of the drum screen, such that fish and debris exit the drum screen from both sides (see Figure 22).

- 6.3.21 The flushing sequence is based on the same principles as those described for the band screens (Section 6.2.17). As the drum rotates, the bucket rises up out of the water and moves around to the top of the screen (See Figure 22).
- (i) As it travels across the top of the drum, the bucket transitions from a horizontal plane to a vertical plane, allowing the contents of the bucket to slide out, under gravity, into the collection hopper.
 - (ii) At this point, the bucket passes the Low Pressure sprays which help to gently flush the fish and debris out of the bucket. There is also a sparge pipe that sprays across the hopper to cushion the fall for the fish and help flush them along;
 - (iii) As the drum continues to rotate, the bucket moves around past the High Pressure sprays which flush more persistent debris out of the bucket and off the screen mesh.
- 6.3.22 Material washed from the screen flows under gravity, being carried in the wash water, out of the hopper and into the collection gutters which carry the fish and debris to the filtering debris recovery pit (HCB) (see Sections 6.4 and 7). Fish and debris travel in common gutter to the filtering debris recovery pit (HCB).

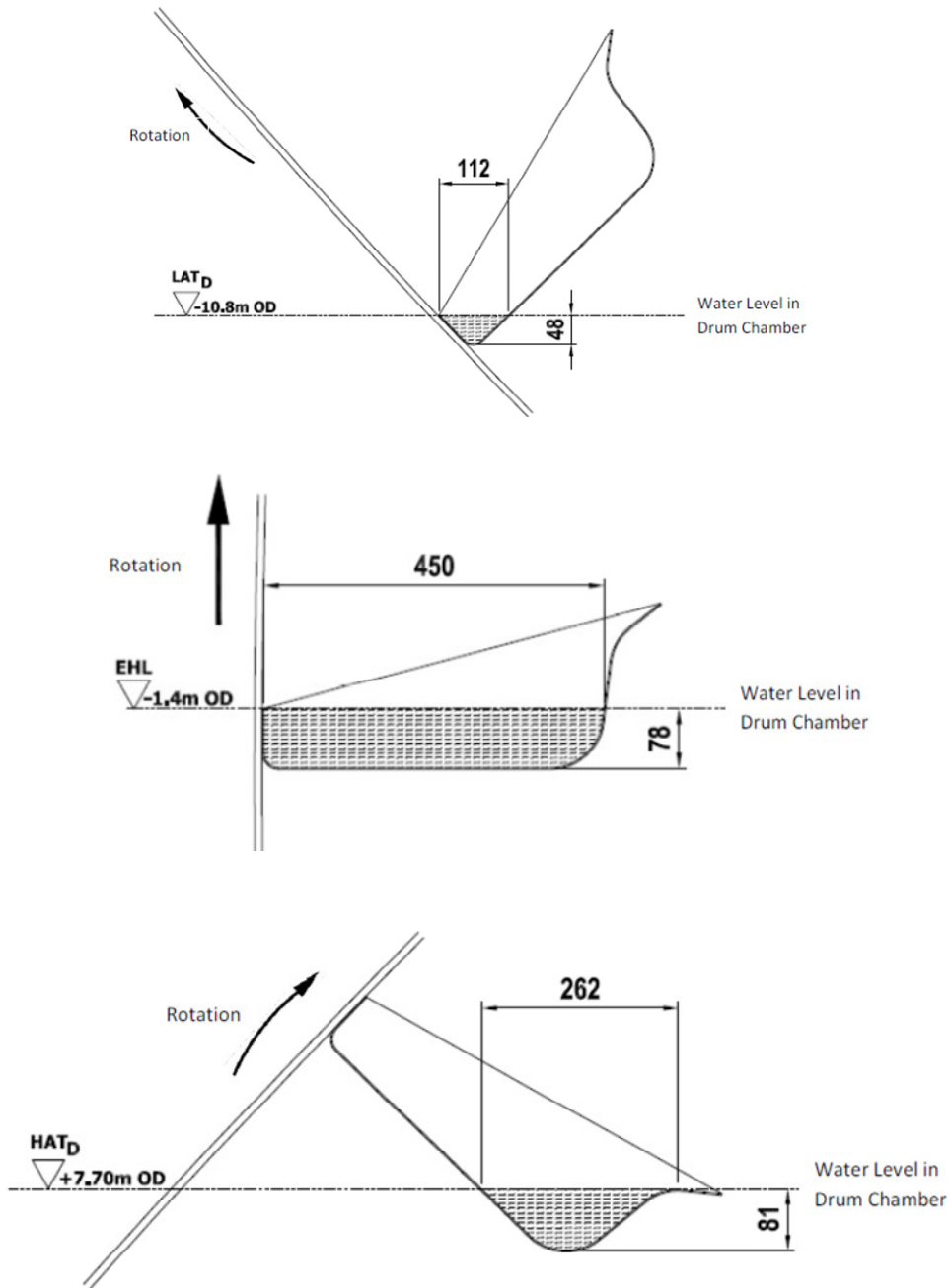

Figure 21: Water depths in the drum screen buckets as they emerge from the water in the screen well at various tidal levels. Top = LAT, Middle = mid tide, Bottom = HAT).

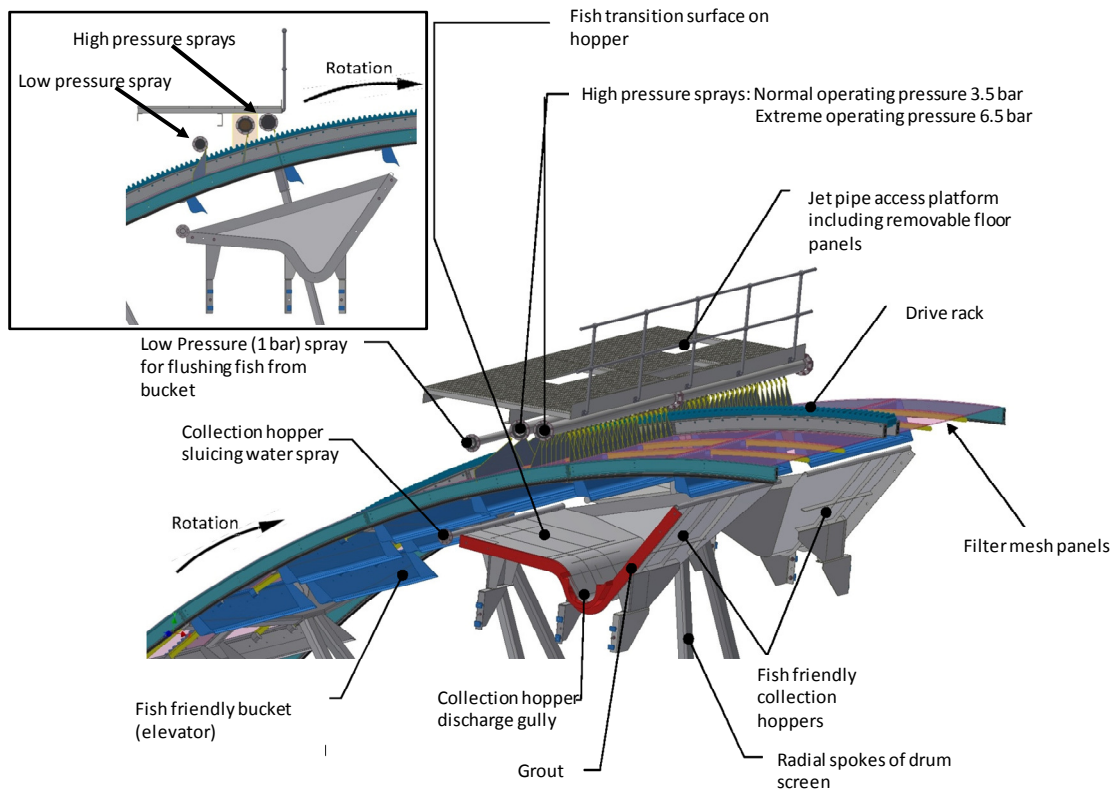

Figure 22: Detailed section of drum screen discharge assembly

6.4 Cooling water pump house (HP) Collection gutters

- 6.4.1 Fish and debris are transported from the debris racks, the band screens and the drum screens by gutters to the filtering debris recovery pit (HCB). The material is flushed along under gravity by both the wash water from those systems and, in places, by additional wash water supplied from the auxiliary cooling water (SEN) system. See Ref [9].
- 6.4.2 The gutter routing can be seen in Figure 23.
- 6.4.3 Coarse filtration (SEF) gutters
- 6.4.4 The material from the debris racks (coarse filtration / SEF) is transported to the filtering debris recovery pit (HCB) in a single gutter common to all racks, except train 1. Material is deposited directly into this common gutter.

- 6.4.5 The raking system for one of the band screens (train 1) has its own a dedicated gutter, separate from the raking systems for the other band screen and two drum screens (trains 2, 3 and 4), to provide diversification (redundancy) for nuclear safety purposes⁸.
- 6.4.6 The internal surface of the coarse filtration gutters will be finished with High Density Polyethylene (HDPE) (or a material of similar smoothness) so the surface will be very smooth. ‘Smoothness’ can be expressed by the Strickler coefficient and for the gutters in the cooling water pump house (HP) the value is $100 \text{ m}^{1/3} \text{ s}^{-1}$ – this is high and indicative of a very smooth surface.
- 6.4.7 The gutters for the coarse filtration (SEF) system will have a diameter of 600 mm.
- 6.4.8 The coarse filtration (SEF) gutter for trains 2, 3 and 4 will have a gradient of 0.5%, and the gutter for train 1 will have a gradient of 1.0%.
- 6.4.9 The flow hydraulics for the coarse filtration (SEF) system gutters are summarised in Table 5. This flow is dominated by water supply tapped from the auxiliary cooling water (SEN) (although some water is collected in the debris (trash) rake buckets, the volume is negligible when compared to that tapped from the auxiliary cooling water (SEN) system).
- 6.4.10 For the common gutter for trains 2, 3 and 4, the flow rate tapped from the auxiliary cooling water (SEN) will range from 425 to $685 \text{ m}^3 \text{ h}^{-1}$, depending on the discharge from the washing spray s. Flow velocity will range from 1.58 to 1.80 m s^{-1} , depending flow volume.
- 6.4.11 For the gutter for train 1, the flow rate tapped from the auxiliary cooling water (SEN) system will range from 95 to $155 \text{ m}^3 \text{ h}^{-1}$, depending on the discharge from the washing spray s. Flow velocity will range from 1.30 to 1.50 m s^{-1} , depending on head loss due to tidal levels.
- 6.4.12 The flushing flow drawn from the auxiliary cooling water (SEN) system is the maximum amount of flow that can be diverted to the cooling water pump house (HP) gutters without adversely impacting the flow to other systems, namely the conventional island closed cooling water (SRI) system and the condenser vacuum system (CVI) heat exchangers. Supply to the conventional island closed cooling water (SRI) system and the condenser vacuum system (CVI) heat exchangers is the auxiliary cooling water (SEN) system’s primary purpose. The flushing flow rates are $95 - 155 \text{ m}^3 \text{ h}^{-1}$ for train 1 (the individual band screen debris rake gutter) and $425 - 685 \text{ m}^3 \text{ h}^{-1}$ for trains 2, 3 and 4 (the drum screens and remaining band screen gutter).
- 6.4.13 Depth of water in the gutters will be 190 mm to 240 mm for the gutter serving the debris racks for trains 2, 3 and 4 and 80 mm to 100 mm for the gutter serving the debris rack for train 1.

Table 5: Flow hydraulics for the coarse filtration (SEF) system collection gutters.

⁸ As explained in Section 4.8, the band screens are responsible for filtration of the auxiliary and safety circuits cooling water. Providing each band screen with its own separate gutter means that should one become unavailable, the other will still provide cooling water filtration for those essential, safety systems.

Gutter	Slope	Flow Rate (m ³ h ⁻¹)	Flow velocity (m s ⁻¹)	Draft of water (mm)
Trains 2, 3 and 4	0.5	425 – 685	1.58 – 1.80	190 – 240
Train 1	1.0	95 - 155	1.30 – 1.50	80 - 100

6.4.14 The mechanism by which material (debris and large fish) exits the debris (trash) rakes is described in Section 6.1 (see Figures 14 and 15). As the material exits the debris rake it falls into the collection gutter and the height of this drop from each rake necessarily varies because the collection gutter slopes across the cooling water pump house (HP). The drop height increases along the collection gutter from approximately 300 mm at train 4 to approximately 700 mm at train 1 because the gutter slopes downwards from train 4 to train 1.

6.4.15 Drop heights across along the debris (trash) rakes into the collection gutter are presented in Table 6⁹.

⁹ At present, the drop heights are presented relative to the cooling water pump house (HP) surface slab level (set at 10.14 m ODN); the rake tipping point may not be [precisely at this level because the supplier (Ovivo) will determine the exact tipping point of the debris (trash) rakes at the detailed design stage. However, Ovivo are instructed to optimise this to make the drop as small as possible.

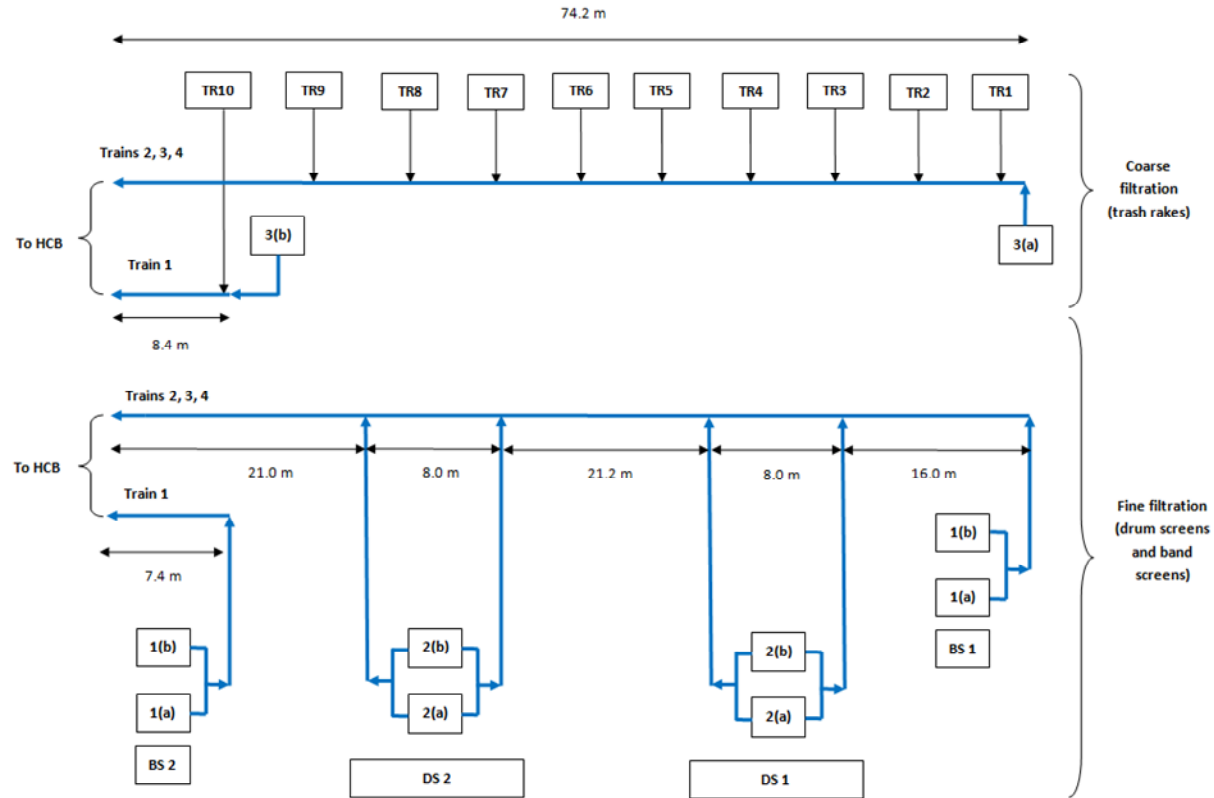

Figure 23: Schematic of cooling water pump house (HP) gutter routing. DS = drum screen; BS = band screen; TR = trash(debris) rack. Numbers with bracketed letters refer to gutter rinsing flow inputs: 1(a) = band screen (train 4) very low pressure spray; 1(b) = band screen(train 4) low pressure + high pressure sprays; 2(a) = drum screen very low pressure spray; 2(b) = drum screen low pressure + high pressure sprays; 3(a) = trash (debris) rack gutter rinsing flow; and, 3(b) = band screen (train 1) gutter rinsing flow.

Table 6: Drop heights from the coarse filtration (SEF) system rakes into the collection gutters (see footnote ⁷ Section 6.4.15).

Point	Invert level of main gutter (m ODN)	Draft of water in main gutter (m)	Water level in main gutter (m ODN)	Vertical drop (from 10.14 mODN) (m)
TR1	9.66	0.19 – 0.24	9.85 – 9.90	0.29 – 0.24
TR2	9.62		9.81 – 9.86	0.33 – 0.28
TR3	9.59		9.78 – 9.83	0.36 – 0.31
TR4	9.53		9.72 – 9.77	0.42 – 0.37
TR5	9.50		9.69 -9.74	0.45 – 0.40
TR6	9.47		9.66 – 9.71	0.48 – 0.43
TR7	9.41		9.60 – 9.65	0.54 – 0.49
TR8	9.38		9.57 – 9.62	0.57 – 0.52
TR9	9.35		9.54 – 9.59	0.60 – 0.55
Exit from HP (trains 2, 3 and 4)	9.29			9.48 – 9.53
TR10	9.37	0.08 – 0.10	9.45 – 9.47	0.69 – 0.67
Exit from HP (train 1)	9.29		9.37 – 9.39	N/A

- 6.4.16 Fine filtration (CFI) gutters
- 6.4.17 The material from the band screens falls into 2 separate gutters, one (higher) gutter for fish and debris discharged by the Very Low Pressure sprays and a separate (lower) gutter for the more persistent material washed off by the Low/High Pressure Sprays (see also Section 6.2.17; Figure 18). These then merge when they join a common collection gutter that collects material from both band screens (and both drum screens) to the debris recovery building.
- 6.4.18 All of the material from the drum screens is transported to the filtering debris recovery pit (HCB) in the same common gutter as the used for fish and debris discharged from the band screens. Again, each screen has its own gutters linking its hopper to the common gutter.
- 6.4.19 To provide diversification (redundancy), material from one band screen (train 1) is transported to the filtering debris recovery pit (HCB) in a completely separate gutter from the material from the other band screen and two drum screens (trains 2, 3 and 4).
- 6.4.20 As with the coarse filtration (SEF) system gutters (see section 6.4.6), the internal surface of the gutters for the fine filtration (CFI) system will also be finished with High Density Polyethylene (HDPE) (or a material of similar smoothness) so the surface will be very smooth (Strickler coefficient = $100 \text{ m}^{1/3} \text{ s}^{-1}$; this is high and indicative of a very smooth surface).
- 6.4.21 The hydraulics of the debris gutters at Hinkley Point C have been optimised to improve their fish friendliness, both in respect of their geometry and their flow rates.
- 6.4.22 All gutters for the fine filtration material (band screens and drum screens; CFI) are 400 mm diameter.
- 6.4.23 The gutters that collect and transfer material from the individual drum screens to the common collection gutter have a gradient of 2.0%. The gutters that collect and transfer material from the individual band screens to the common collection gutter are likely to have a similar gradient, but this will only be confirmed at the detailed design stage by the supplier, Ovivo.
- 6.4.24 The common collection gutter has a gradient of 0.5%.
- 6.4.25 Flow in the upper (fish) collection gutter of the band screen for train 1 comprises water from the fish collection buckets, water from the wash sprays (Very Low Pressure) only.
- 6.4.26 Water flow in the common collection gutter that serves the two drum screens (trains 2 and 3) and the material from the band screen for train 4 comprises water from the drum screen wash sprays (Very Low Pressure plus Low/High Pressure), water from the band screen (train 4) wash sprays (Very Low Pressure only).
- 6.4.27 Water level in the connection gutters (from the screens to the common gutter) will be 100 – 130 mm deep.
- 6.4.28 Water level in the common collection gutter will vary across its length. In Figure 23, which shows the gutter routing of the cooling water pump house (HP), the flow is from right to left. It can be seen that as the material flows from right to left (east to west) more and more material and water are added to the gutter as it passes the various screens (trains 4, 3 and 2, respectively). As it does so, the water level in the gutter

increases from 100 – 120 mm at the start to 380 – 450 mm at the point the gutter exits the cooling water pump house (HP).

- 6.4.29 Figure 24 shows the flow dynamics (volume, velocity and depth of water) in the fine filtration (CFI) gutters. This information is summarised in Table 7

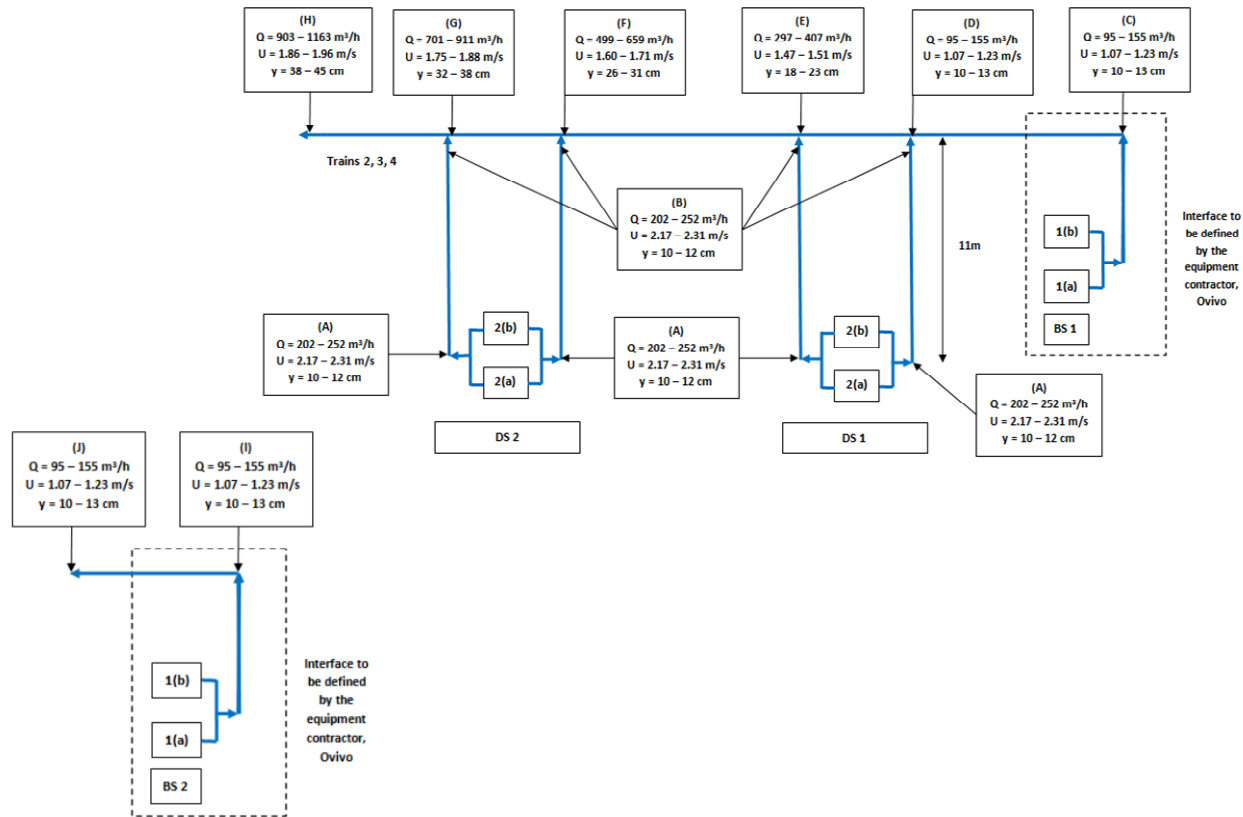

Figure 24: Summary of the flow dynamics of the cooling water pump house (HP) fine filtration (CFI) gutters. DS drum screen; and, BS = band screen. Q = volumetric flow rate; U = flow velocity in each gutter section; and, y = depth of water in each gutter section. Other labels are as defined in Figure 23 for each flow input.

Table 7: Flow hydraulics in cooling water pump house (HP) gutters. See also Figure 24 for location points. All gutters are diameter 400 mm and have Strickler coefficient (K; $m^{1/3}/s$) of 100.

Point	Description	Slope	Flow rate ($m^3 h^{-1}$)	Flow velocity ($m s^{-1}$)	Draft of water (mm)
A	Start of drum screen gutters	2.0	202 – 252	2.17 – 2.31	100 – 120
B	Intersection of DS gutters with train 2, 3, 4 gutter				
C	Start of train 2, 3, 4 common gutter	0.5	95 – 155	1.07 – 1.23	100 – 130
D	Train 2, 3, 4 Common gutter				
E	intersection with DS1 gutters	0.5	297 – 407	1.47 – 1.51	180 – 230
F	Train 2, 3, 4 gutter	0.5	499 – 659	1.60 – 1.71	260 – 310
G	intersection with DS2 gutters	0.5	701 – 911	1.75 – 1.88	320 – 380
H	Train 2, 3, 4 gutter at exit from HP	0.5	903 – 1163	1.86 – 1.96	380 – 450
I	Start of train 1 gutter	0.5	95 – 155	1.07 – 1.23	100 – 130
J	Train 1 gutter at exit from HP				

6.4.30 The cooling water pump house gutter network has been designed such that, wherever, possible, there are no vertical drops where the individual connection gutters from the band and drum screens meet the common connection gutter. Due to civil design constraints, two intersections may have vertical drops between the connection gutters and the water surface of the common gutter (depending on flow rates) but the drops

are only very small (maximum 30 mm). Information on vertical transitions between connection gutters and the common gutter are presented in Table 8.

Table 8: Drop heights from the individual collection gutters from the band and drum screens into the common collection gutter.

Intersection	Invert level of main gutter (m OD)	Draft of water in main gutter (m)	Water level in main gutter (m OD)	Invert level of DS/BS gutter into main gutter (m OD)	Vertical drop from DS/BS gutter to main gutter (m)
BS1 – C	9.57	0.10 – 0.13	9.67 – 9.70	Interface to be defined by equipment contractor, Ovivo	
DS1: B – D	9.49	0.10 – 0.13	9.59 – 9.62	9.62	0.03 – nil
DS1: B – E	9.45	0.18 – 0.23	9.63 – 9.68		nil – nil
DS2 : B – F	9.34	0.26 – 0.31	9.60 – 9.65		0.02 – nil
DS2 : B – G	9.30	0.32 – 0.38	9.62 – 9.68		nil – nil
H – Exit from HP	9.20	0.38 – 0.45	9.58 – 9.65	N/A	N/A
BS2 – I	9.24	0.10 – 0.13	9.34 – 9.37	Interface to be defined by equipment contractor, Ovivo	
J – Exit from HP	9.20	0.10 – 0.13	9.30 – 9.33	N/A	N/A

- 6.4.31 To improve the transmittal of fish and debris through the intersection of the individual collection gutters and the common collection gutter, the ends of the individual gutters are curved (Figure 25) so that the individual gutters ‘sweep’ into the common collection gutter.
- 6.4.32 As the gutter diameters are 400 mm (see Section 6.4.22), bends should have a radius of at least 600 mm (1.5 × diameter) to meet best practice. The radius of the swept curves at the end of the individual collection gutters are 600 mm.

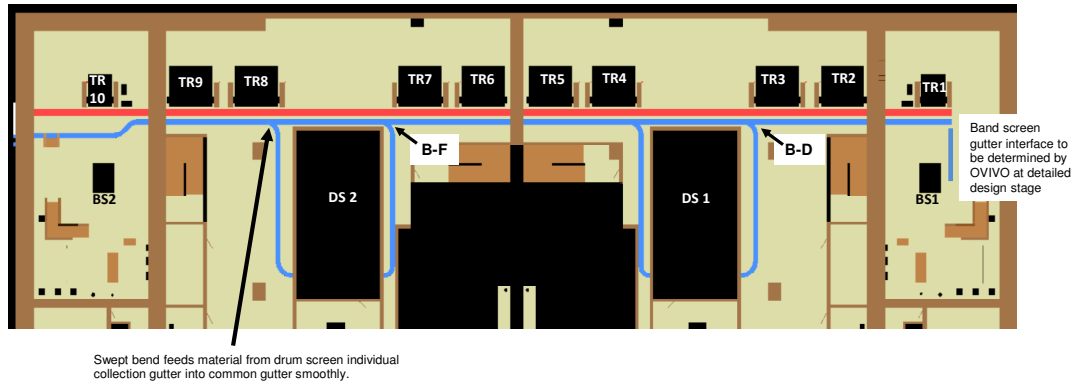

Figure 25: Drum screen gutter transitions in cooling water pump house (HP) (codes as for Figure 24). Individual collection gutters from the drum screens feed into the common collection gutter via swept bends of 600 mm radius. Drops (maximum 30 mm) occur at only 2 of the transitions, marked as B-F and B-D (see Table 7 for full details). The interface between the individual band screen gutters and the common gutter will be determined by the supplier (Ovivo) at the detailed design stage.

6.4.33 Material from the coarse (SEF) and fine (CFI) filtration systems exit the cooling water pump house (HP) (to the left on Figures 23 to 25) and flow directly into the filtering debris recovery pit (HCB).

7 FILTERING DEBRIS RECOVERY PIT (HCB)

- 7.1.1 Material from the coarse (SEF) and fine (CFI) filtration systems exit the cooling water pump house (HP) (to the left on Figures 23 to 25) and flow directly into the filtering debris recovery pit (HCB) (Ref [10]).
- 7.1.2 The role of the filtering debris recovery pit (HCB), as its name suggests, is to recover the debris that the coarse (SEF) and fine (CFI) filtration systems have removed from the cooling water. The debris removed is disposed to a licensed waste disposal facility. For stations that have a Fish Recovery and Return system (as at HPC) there is a need for the debris recovery building to be modified in two aspects:
- (i) the raking system for removing the debris needs to allow as many fish as possible to pass through unharmed; and,
 - (ii) there needs to be a route back to sea for the fish recovered from the coarse (SEF) and fine (CFI) filtration systems.
- 7.1.3 The raking system is, therefore, constrained by the need to prevent the route back to sea from being blocked by pieces of large debris. The route to sea, in this context, comprises two elements:
- (i) an Archimedes' screw which is required to lift the water, fine debris and fish to an elevation that is high enough to allow return to sea under gravity (in this case 12.8 m ODN); and,
 - (ii) the fish return (HCF) system, which comprises a connection gutter, tunnel back to sea and outfall head structure.
- 7.1.4 Material arriving at the filtering debris recovery pit (HCB) from the coarse (SEF) and fine (CFI) filtration systems is handled differently:
- (i) material recovered by the coarse (SEF) filtration system will have a minimum size such that it do not pass through a 50 mm rack and an unconstrained maximum size (other than it must be able to enter the 270 × 2000 mm intake head aperture). This material must, therefore, be re-filtered to remove material large that could potentially block the return to sea (i.e. the Archimedes' screw in the filtering debris recovery pit (HCB) and the fish return (HF) system gutter and tunnel);
 - (ii) material recovered from the fine (CFI) filtration system has already passed through the 50 mm rack of the coarse (SEF) filtration system and can, therefore, be transferred back to sea without risk of blocking the route to sea (i.e. the Archimedes' screw in the filtering debris recovery pit (HCB) and the fish return (HCF) system gutter and tunnel). Material from the fine filtration (CFI) system, therefore, by-passes the debris recovery (HCB) raking system and is returned directly to sea via the Archimedes' screw and fish return (HCF) system.
- 7.1.5 The filtering debris recovery pit (HCB) is shown in plan view in Figure 26 and in section in Figure 27. As can be seen, it can essentially be considered as two components, the basin that receives the material from the filtration systems and the Archimedes' screw used to elevate the water, debris and fish to allow gravity led discharge to sea (see Ref [10]).

- 7.1.6 As described in Section 6.4, flow rates and velocities of water entering the debris recovering (HCB) building from the coarse (SEF) filtration gutter for trains 2, 3 and 4 (the common collection gutter) are 425 to 685 m³ h⁻¹ and 1.58 to 1.80 m s⁻¹, respectively. Flow rate and velocity of water from the coarse (SEF) gutter from train 1 are 95 to 155 m s⁻¹ and 1.30 to 1.50 m s⁻¹, respectively. This information is summarised in Table 9.
- 7.1.7 Flow rate and velocity of water entering the debris recovering (HCB) building from the fine (CFI) filtration gutter for trains 2, 3 and 4 (the common collection gutter) are 903 to 1163 m³ h⁻¹ and 1.86 to 1.96 m s⁻¹, respectively. Flow rate and velocity of water from fine filtration (CFI) gutter from train 1 are 95 to 155 m³ h⁻¹ and 1.07 to 1.23 m s⁻¹, respectively (see Table 9). Water flow through the filtering debris recovery pit (HCB) are shown in Figure 28

Table 9: Flow hydraulics for material entering the filtering debris recovery pit (HCB) (see also Section 6.4)

Filtration system	Train	Invert level (m ODN)	Flow rate (m h ⁻¹)	Flow velocity (m s ⁻¹)	Draft of water (mm)
Coarse (SEF)	1	9.29	95 to 155	1.30 to 1.50	80 to 100
	2, 3 and 4	9.29	425 to 685	1.58 to 1.80	180 to 240
Fine (CFI)	1	9.2	95 to 155	1.07 to 1.23	100 to 130
	2, 3 and 4	9.2	903 to 1163	1.86 to 1.96	380 to 450

- 7.1.8 Water, debris and fish enter the filtering debris recovery pit (HCB) from the coarse (SEF) filtration gutter at an invert level of 9.39 m ODN, and from the fine (CFI) filtration gutter at 9.20 m ODN. Water level in the filtering debris recovery pit (HCB) basin will be maintained at 9.39 m ODN also by means of the Archimedes' screw operating at variable speed.
- 7.1.9 Energy dissipation in respect of the drop from the coarse (SEF) and fine (CFI) gutters into the filtering debris recovery pit (HCB), therefore, is simply a function of the water depth in the gutters and so varies between the two gutters and also between operational flow rate (Ref [10]):
- 7.1.10 Energy dissipation for material dropping from the coarse filtration (SEF) system varies between 16 and 33 W m³; and,
- 7.1.11 Energy dissipation for material dropping from the fine filtration (CFI) system varies between 68 and 100 W m³.
- 7.1.12 Power dissipation higher for the material dropping from the fine filtration system because a greater volume of water is being dropped. For the same reason, the higher values for both drops relate to greater volumes associated with higher (maximum) operation flows.

- 7.1.13 Material exiting the cooling water pump house (HP) from the coarse filtration (SEF) and fine filtration (CFI) system initially enter the filtering debris recovery pit (HCB) in different channels:
- 7.1.14 Material from the coarse filtration (SEF) system enters a channel 1.5 m wide and 3 m long before passing through an additional coarse filtration raking system. After the raking system the channel tapers to 0.9 m wide for a further 3.5 m; the purpose of the tapering being to increase velocity and so reduce the potential for siltation.
- 7.1.15 Material from the fine filtration (CFI) system enters a parallel channel that is 1.1 m wide along its entire 6.5 m length and has no additional coarse filtration rake in this channel.
- 7.1.16 The two channels then merge into a common basin that is 1.1 m wide by 1.81 m long from where they are diverted into one of two channels leading to the Archimedes' screws.
- 7.1.17 The filtering debris recovery pit (HCB) has two Archimedes' screws but only one will operate at any one time (the other provides a second unit that can be used while the first Archimedes' screw is being serviced). Each Archimedes' screw is served by its own dedicated channel, and flow is diverted to the operating channel by a sluice.
- 7.1.18 As described at Section 7.1.4 material from the coarse (SEF) filtration system passes through an additional debris (trash) rack and raking system, the purpose of which is to remove large material that could potentially obstruct the route back to sea.
- 7.1.19 The trash rake itself, in the filtering debris recovery pit (HCB) will be a 'Bosker'- type rake (see Figure 29). The rake traverses a monorail and ascends/descends on a cable winch. The rake cleans the trash rack on the down stroke by gravity with the grab in the open position. Once fully descended, the grab snaps shut with the aid of hydraulic actuators and then ascends back to the top. The rake then traverses the monorail across to the platform and deposits the contents into a skip, which is evacuated by lorry once full. The rake will operate on both head loss and an adjustable timer.

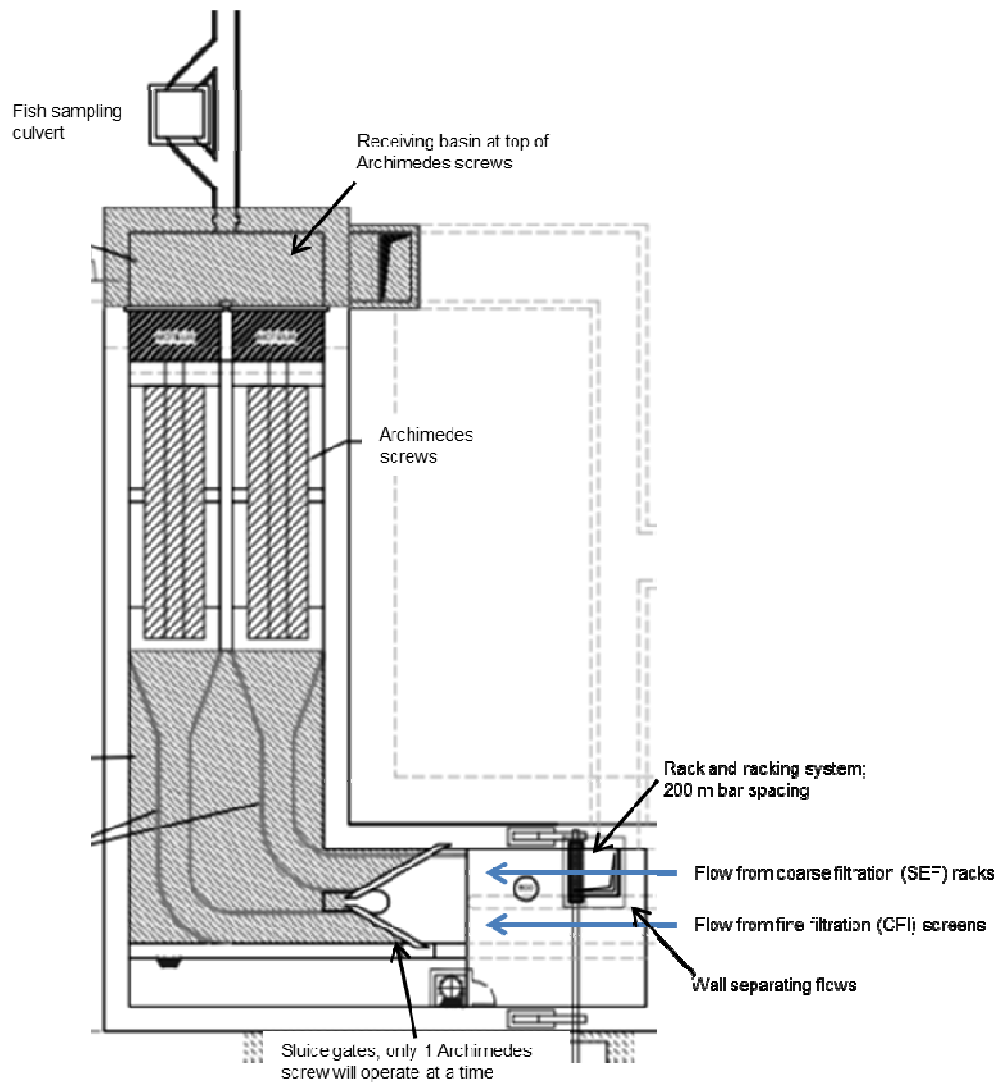

Figure 26: Plan view of filtering debris recovery pit (HCB)

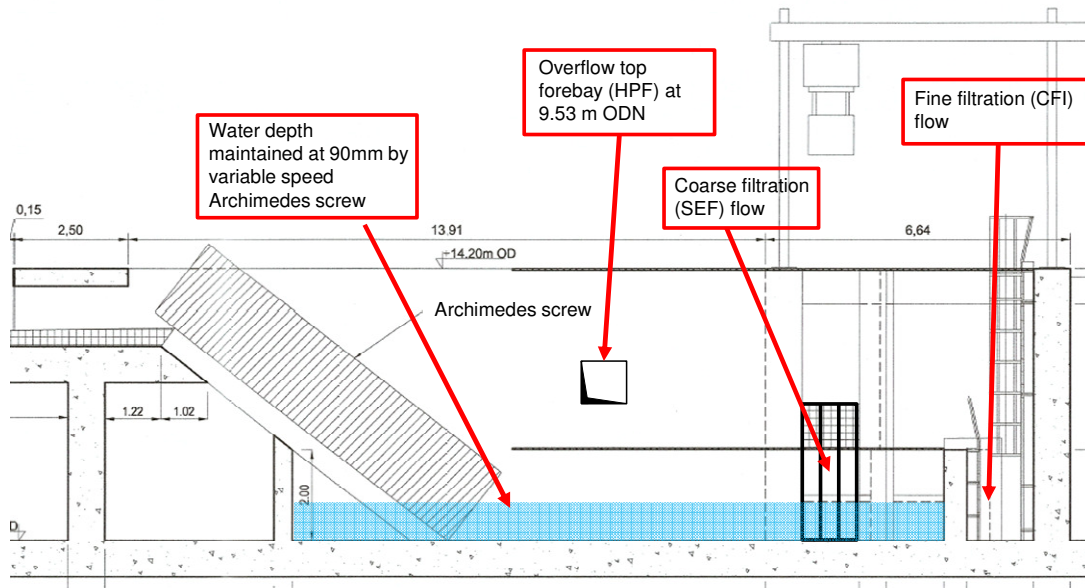

Figure 27: Section through filtering debris recovery pit (HCB)

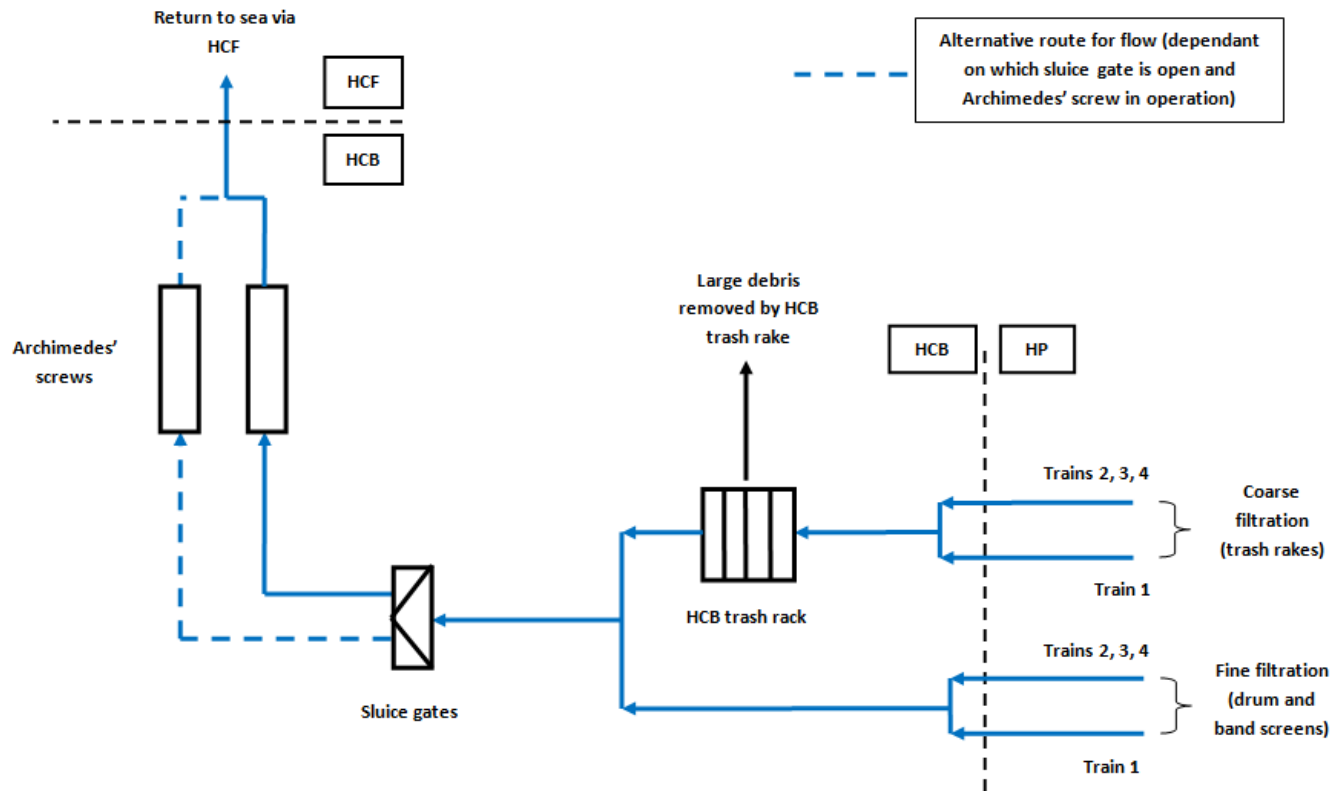

Figure 28: Schematic of flow through the filtering debris recovery pit (HCB)



Figure 29: Bosker'- type rake

- 7.1.20 Material recovered from the filtering debris recovery pit (HCB) rack and raking system is disposed of to a licensed waste disposal facility so any fish recovered by this rack and raking system will not be returned to sea. In order to allow as many fish to sea as possible, the rack spacing is sized as large as possible to allow as many large fish to pass through as possible, but small enough to adequately protect the Archimedes' screw and fish return (HCF) system from obstruction.
- 7.1.21 Empirically, the bar spacing must be at least 3 times smaller than the diameter of the pipe. At Hinkley Point C, the filtering debris recovery pit (HCB) debris (trash) rake is sized at 200 mm bar spacing (giving a ratio of 1:3.3; Figure 26).
- 7.1.22 Water, fine debris and fish exit the filtering debris recovery pit (HCB) via one of two installed Archimedes' screws.
- 7.1.23 As described earlier, the purpose of the Archimedes' screws is to elevate the water, debris and fish so that they can be returned to sea by gravity.
- 7.1.24 Discharge of water, debris and fish back to sea directly from the filtering debris recovery pit (HCB) basin is not possible due to the large tidal range at Hinkley Point and the various platform levels of Hinkley Point C. A detailed analysis of this issue is provided in Ref [11]. In summary, if a tunnel was taken direct from the floor of the filtering debris recovery pit (HCB) to discharge water, debris and fish below low water on the very lowest tide (Lowest Astronomical Tide, LAT) the filtering debris recovery pit (HCB) would not be able to drain completely at certain states of the tide (i.e. a high water levels on higher (Spring) tides). This is because the tunnel itself would be partially full due to tidal inundation and because friction (also referred to as head loss) in the tunnel would prevent the water from draining properly. It is possible should the filtering debris recovery pit (HCB) not drain adequately that the water level could rise to such an extent

that it could cause water in the filtration gutters to back up and overflow in the cooling water pump house (HP). To prevent this risk of flooding in the cooling water pump house (HP) there is an overflow channel from the filtering debris recovery pit (HCB) back to the forebay (HF) at a lower invert level than the filtration gutters. A discharge direct to sea from the filtering debris recovery pit (HCB), whereby water does not drain efficiently at high water, increases the possibility of the overflow being used, leading to recirculation and, potentially, notifiable shut down events. For this reason, there is a need to elevate the fish and an Archimedes' screw is a suitable method to do so.

- 7.1.25 Two Archimedes' screws will be fitted (see Figure 26), but only one will operate at any one time (the other is available for faults or servicing). A sluice gate is installed in the filtering debris recovery pit (HCB) basin seal the non-operating Archimedes' screw so that water, debris and fish are diverted to the operating Archimedes' screw.
- 7.1.26 The Archimedes' screws will be fully enclosed or 'shrouded', meaning that the blades lie within an outer casing, to which they are attached, so that the whole assembly rotates as one unit. The use of a 'shrouded' Archimedes' screw design is specifically to improve fish protection as it removes the interface between the blades and the concrete chute on 'unshrouded' screws which can cause pinching of fish and fins. 'Shrouded' Archimedes screws are more onerous to clear should the screw become blocked, hence the second screw being fitted for diversification.
- 7.1.27 The leading edges of the Archimedes' screw will be rounded to improve fish protection.
- 7.1.28 The exact dimensions of the Archimedes' screws are not yet available as they will be determined at the detailed design stage by the equipment supplier (yet to be confirmed). This will define the diameter and number of blades of the Archimedes' screw. The specifications are expected to be of the order 11 m in length at an incline angle of between 26° and 38°, with a maximum of 3 flights.
- 7.1.29 The Archimedes' screws will be rotated by a variable frequency drive (VFD). A variable frequency drive allows the Archimedes screw to be rotated at variable speeds to compensate for different flow rates through the filtering debris recovery pit (HCB). The Archimedes' screws will be rotated at the appropriate revolutions per minute to maintain a standing water of 900 mm in the filtering debris recovery pit (HCB) basin. Maintaining the water depth at 900 mm ensures that power dissipation where the filtration (SEF and CFI) gutters enter the filtering debris recovery pit (HCB) basin remains below 100 W m³.
- 7.1.30 Water, debris and fish will exit the top of the Archimedes' screw into a basin immediately prior to discharge into the fish return system gutter. The basin floor is at 12.8 m ODN.
- 7.1.31 The interface between the top of the Archimedes' screw and the basin, in particular the height of the vertical drop from the screw into the basin, is not yet known as it will depend on the length and angle of incline (see 7.1.28). Similarly the depth of water in the basin cannot be defined yet. The design of the interface will be constrained to ensure that the power dissipation for material dropping into the basin from the screw is below 100 W m³.
- 7.1.32 Meeting the above criteria defined in Environment Agency documents will ensure that the Archimedes' screw section of the HCB building is optimised for fish friendliness.

-
- 7.1.33 A long term means of sampling the fish as they travel through the fish recovery and return system is required at HPC to allow comparison of actual fish impingement with predicted (i.e. in the Environmental Impact Assessment (EIA) and Habitats Regulations Assessment (HRA) that supported the application for development consent). This post scheme appraisal is required for the operational Water Discharge Activity environmental permit¹⁰ issued by the Environment Agency.
- 7.1.34 Numbers and types of fish caught as well as fish survivorship through the system will need to be monitored. The basin at the top of the Archimedes' screw is considered the most appropriate place for such sampling because by the time that fish have reached this point they have experienced all mechanical handling within the system (i.e. coarse (SEF) or fine (CFI) filtration, potentially further filtration in the filtering debris recovery pit (HCB) and the Archimedes' screws). Downstream of this location the pipework soon descends underground into the fish return system (HCF) where the fish travel through the fish return gutters and tunnel and out to sea.
- 7.1.35 There is also room at ground level for the necessary temporary storage tank(s) for survivability studies and temporary works area (including temporary welfare facilities).
- 7.1.36 The most efficient, less invasive (in terms of fish handling) way to sample fish from the system is to incorporate a culvert into which flow can be diverted to collect fish (the water re-joins the main gutter usually via a weir-type arrangement) (see Figures 30; Ref [3]). This option will be incorporated into the design if there is sufficient space to do so (see Figure 26)¹¹.
- 7.1.37 If a culverted sampling point cannot be incorporated into the design due to lack of available space then fish sampling will be made by the use of stop nets in the basin to sample fish.

¹⁰ Hinkley Point C Power Station. Permit Number EPR/HP3228XT

¹¹ There is a network of subterranean galleries that need to be accommodated and so there may not be sufficient vertical space to incorporate a culvert design.

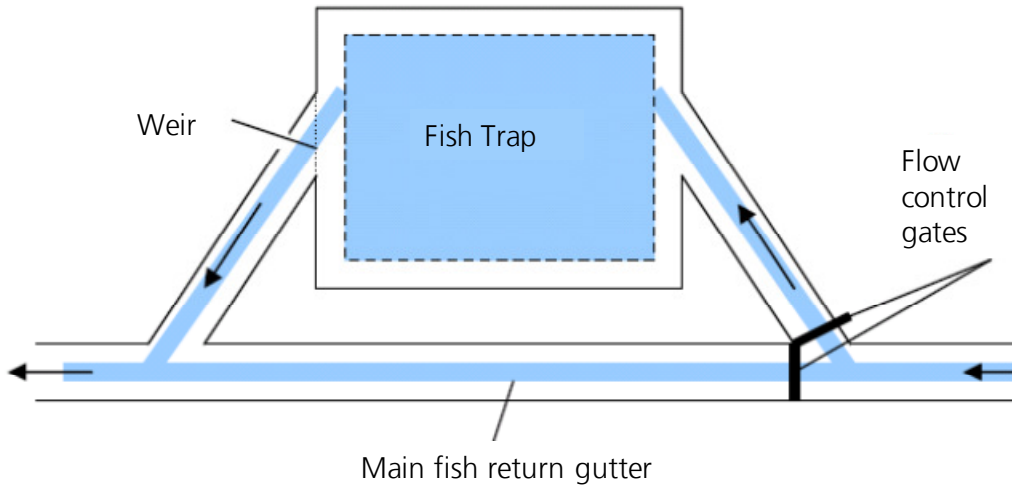

Figure 30: Typical 'culvert' style fish sampling point (Ref [3])

8 FISH RETURN SYSTEM (HCF)

- 8.1.1 The fish return system (HCF) comprises the gutter running from the filtering debris recovery pit (HCB), the tunnel that transfers the water, debris and fish from the Hinkley Point C site to below a point on the shore that lies below low water on the very lowest tide (Lowest Astronomical Tide, LAT), and a concrete outfall head structure. See Ref [12].
- 8.1.2 The fish return system unifies the water, debris and fish from the two units at a junction immediately prior to the fish return tunnel. The routing of the fish return (HCF) system is shown in Figure 31.
- 8.1.3 The fish return system also incorporates a means to sample the fish so that assessments can be made in respect of numbers and types of fish caught as well as fish survivorship through the system.
- 8.1.4 Fish return system (HCF) gutters:
- 8.1.5 The fish return system gutter (HCF) exits the filtering debris recovery pit (HCB) at 12.8 m ODN.
- 8.1.6 The fish return system (HCF) pipes are 651 mm internal diameter.
- 8.1.7 The fish return system (HCF) gutters will be made of High Density Polyethylene (HDPE) (or a material of similar smoothness) so the surface will be very smooth. ‘Smoothness’ can be expressed by the Strickler coefficient and for the gutters in the cooling water pump house (HP) the value is $100 \text{ m}^{1/3} \text{ s}^{-1}$ – this is high and indicative of a very smooth surface.
- 8.1.8 The design parameters of the fish return system (HCF) gutter varies depending on which EPR Unit it serves. The gutter for Unit 2 (the western unit on the Hinkley Point C site) is the longer gutter and has more bends because its starting point is furthest away from the fish return (HCF) tunnel (see Figure 31). Because of this the gradient needs to be shallower.
- 8.1.9 The fish return system (HCF) gutters are 197 and 231 m long for Units 1 and 2, respectively.
- 8.1.10 The fish return system (HCF) gutters slope at 0.65% and 0.56% for Units 1 and 2, respectively.
- 8.1.11 Bends along the two fish return system (HCF) gutters vary in respect of radius, but the gutter diameter is large (0.65 m) and all radii are more than 1.5 times the diameter. The smallest radius for the 90° bends is 3.25 m (equal to 5 times the gutter diameter of 0.65 m). The radius for the 180° bends at the Y-shaped transition structure is also 3.25 m.
- 8.1.12 Discharge rate along each fish return system (HCF) gutter will vary according to operational condition. Maximum flow will be $2268 \text{ m}^3 \text{ h}^{-1}$ and minimum flow will be $1404 \text{ m}^3 \text{ h}^{-1}$. Flow velocities will be in the order of 1.89 m s^{-1} (closed conduit) and 2.02 m s^{-1} (free flow) for maximum and minimum flow rates, respectively¹².

¹² Velocities are presented for a slope of 0.5% gradient

- 8.1.13 Draft of water each fish return system (HCF) gutter will vary according discharge rate, being 400 mm at maximum flow and 350 mm at minimum flow.
- 8.1.14 Flow dynamics in the fish return system gutters are presented in Table 10.

Table 10: Flow hydraulics for the fish return system (HCF gutters)

Scenario	Rate (m ³ h ⁻¹)	Velocity (m s ⁻¹) ⁸	Draft (mm)
Maximum operational flow	2268	1.89 (closed conduit) ¹³	400
Minimum operational flow	1404	2.02 (free surface flow) ⁹	350
2 Unit Outage flow	864	1.73 (free surface flow) ⁹	220

¹³ Free surface flow occurs where the water is not constrained on all sides compared with conduit flow where it is (i.e. the pipe is full); consequently conduit flow experiences great friction which causes increased head loss and slower flow velocities. Flow volume during minimum operational flow and outage are not sufficient to achieve conduit flow (i.e. not sufficient to fill the pipe).

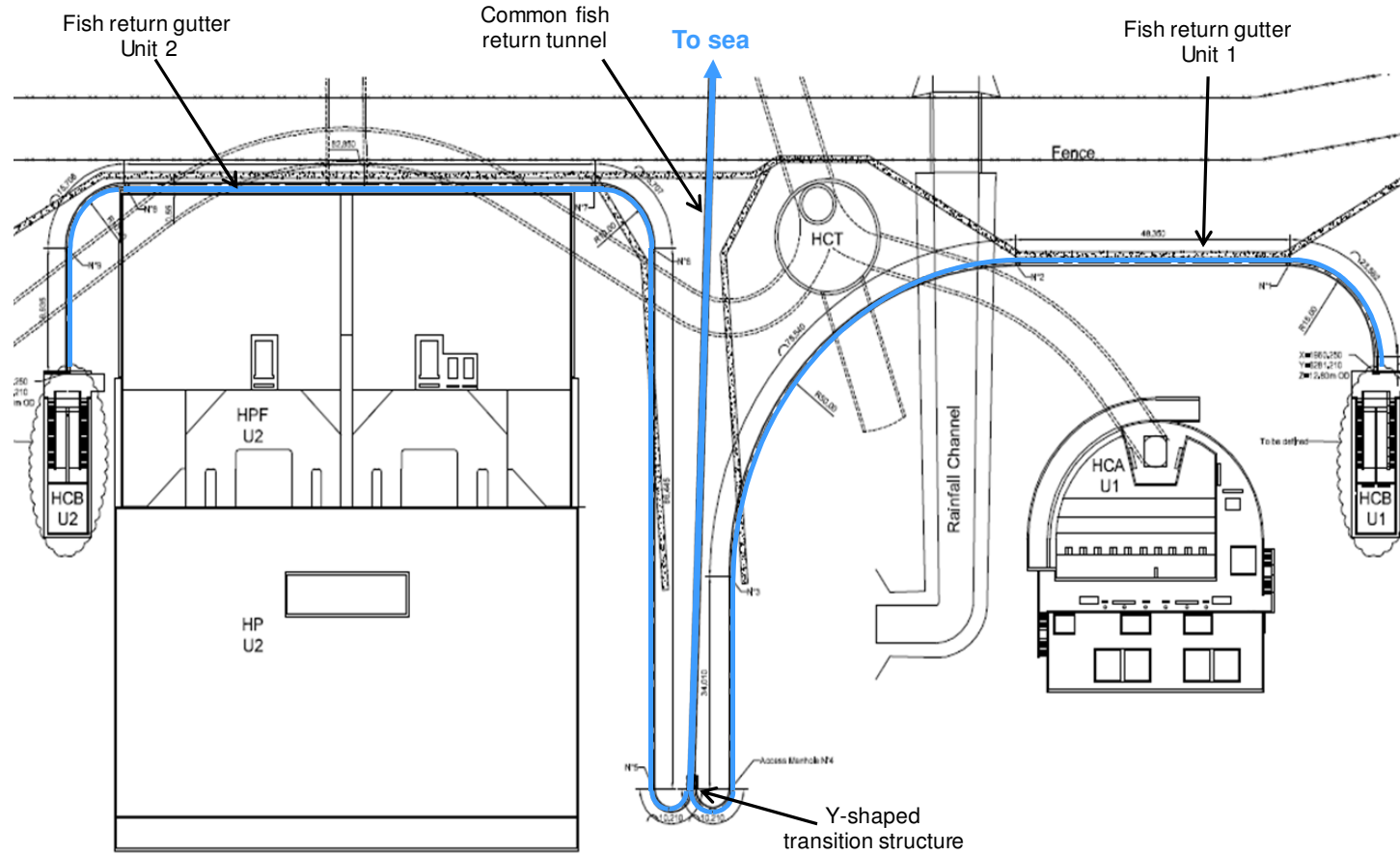

EPR Unit 2

Figure 31: Routing of the Fish Return System (HCF)

-
- 8.1.15 Fish return system (HCF) transition structure
- 8.1.16 The two fish return system (HCF) gutters join at a Y-shaped transition structure, where their contents merge as they enter the fish return system (HCF) tunnel (see Figure 32).
- 8.1.17 The long fish return system (HCF) gutter lengths before the transition structure are to allow the gutter elevation to be low enough such that a continuous slope can be used to return the fish to sea. From the exit from the filtering debris recovery pit (HCB) (at 12.8 m ODN) to the fish return system (HCF) outfall (at -6.10 m ODN for lowest astronomical tide, LAT) there is a vertical drop of 18.9 m. To achieve this drop in elevation at suitable gradients (between 0.56 and 0.65 % and an average of 10.9% for the fish return system (HCF) gutters and tunnel, respectively), the fish return system (HCF) gutters need to meander southwards from their exits from the filtering debris recovery pit (HCB)s to provide a long enough run to achieve the required gradient.
- 8.1.18 Access chambers will be incorporated along the fish return system (HCF) gutters at 100 m intervals and at every point where the gutters change direction.
- 8.1.19 The gutters curve 180° (to flow north) immediately before they enter the Y-shaped transition structure. The radius of the curve is 3.25 m (5 times the gutter diameter of 0.65 m).
- 8.1.20 As the two separate fish return system (HCF) gutters merge the diameter increases from 0.65 m for each gutter to 0.938 m for the fish return system (HCF) tunnel.
- 8.1.21 An access chamber with a removable cover slab lies above the Y-shaped transition structure to allow maintenance of the tunnel.

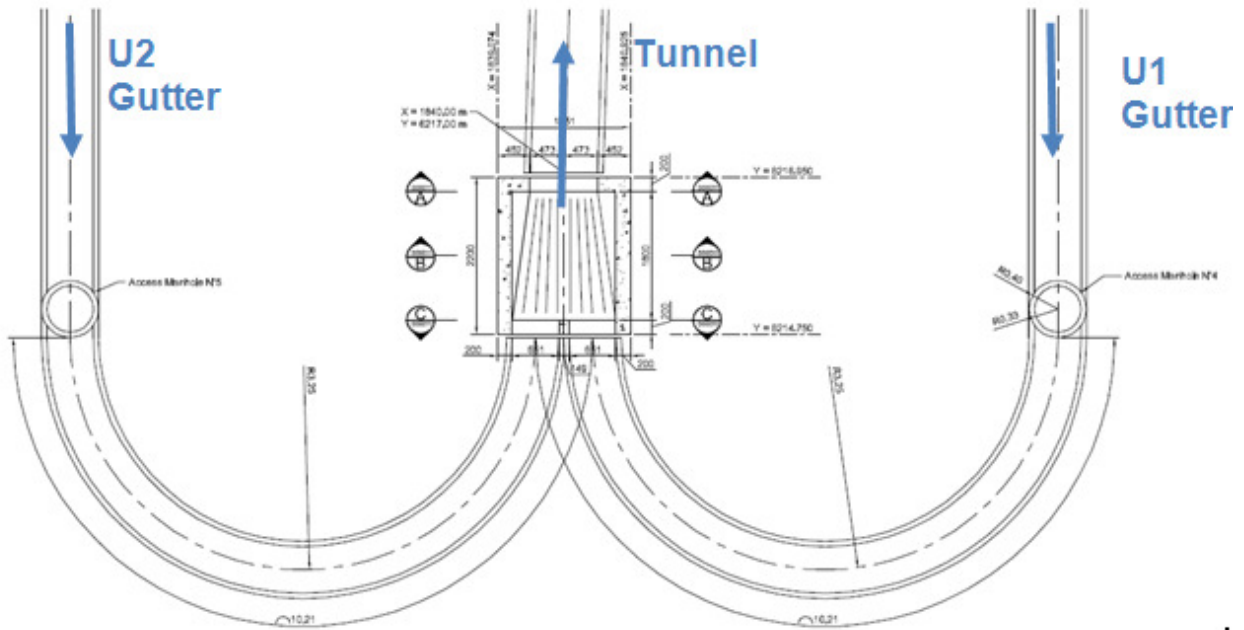

Section A-A
Scale 1/25

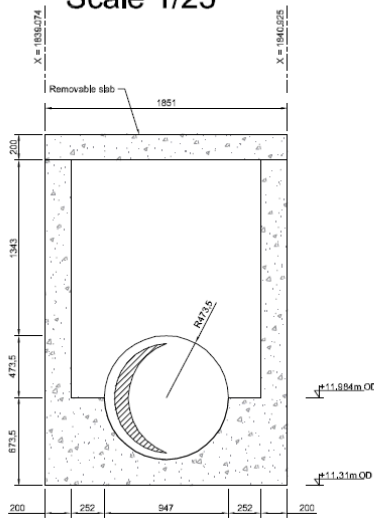

Section B-B
Scale 1/25

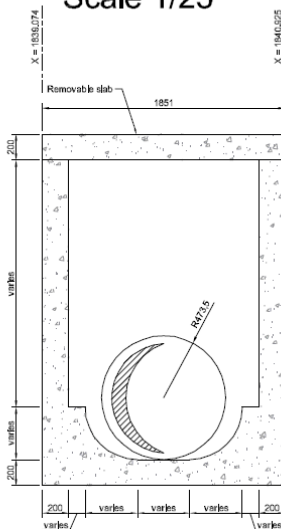

Section C-C
Scale 1/25

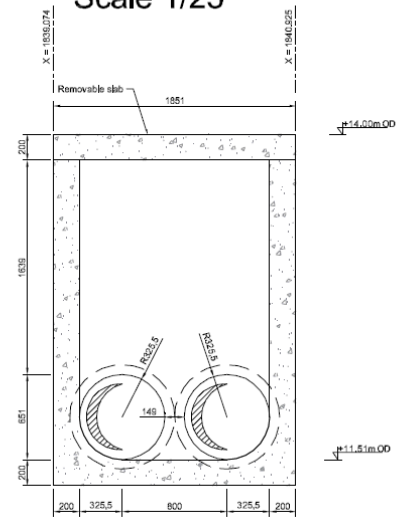

Figure 32: Transition structure for the fish return system (HCF)

Fish return system (HCF) tunnel

- 8.1.22 The fish return system (HCF) tunnel will be curved vertically; it will descend, underneath the sea wall and rock platform before rising up again for the outfall point below the lowest low water mark (Lowest Astronomical Tide; LAT) (Figure 33).
- 8.1.23 The tunnel will be 658 m in length and 0.938 m internal diameter.
- 8.1.24 The tunnel will be lined with High Density Polyethylene (HDPE) (or a material of similar smoothness) so the surface will be very smooth. 'Smoothness' can be expressed by the Strickler coefficient and, for the fish return tunnel (HCF), the value is $100 \text{ m}^{1/3} \text{ s}^{-1}$ – this is high and indicative of a very smooth surface.
- 8.1.25 The fish return system (HCF) tunnel starts at 11.51 m ODN, at which point it has a gradient of 13.7%. The gradient of the fish return system (HCF) tunnel varies due its vertically curved path; the average slope is 10.9 % (Ref [12]).
- 8.1.26 Due to the tidal nature of the Hinkley Point C site, the depth to which the fish return system (HCF) tunnel is flooded is variable because it opens into the sea. The highest point of flooding will be at high water on the Highest Astronomical Tide (HAT) and the lowest will be at low water on the Lowest Astronomical Tide (LAT). However, due to friction in the fish return system (HCF) tunnel, these flooded levels are at higher elevations than the tidal level on the shore (for example, + 1.2 m at LAT).
- 8.1.27 The longest tunnel length that will be non-flooded (at low water on the Lowest Astronomical Tide (LAT)) is 152 m. At the flooded/non-flooded interface for LAT the tunnel will have a gradient of 12%.
- 8.1.28 The flooded and non-flooded nature of the fish return system (HCF) tunnel means that water flow along its length occurs as two types: free surface flow (in the non-flooded sections) and conduit flow (in the flooded sections). Free surface flow occurs where the water is not constrained on all sides compared with conduit flow where it is (i.e. the pipe is full); consequently conduit flow experiences great friction which causes increased head loss and slower flow velocities. Thus, due to the tidal nature of the Hinkley Point C site, therefore, free surface flow is a transient condition varying according to tidal state (reaching a maximum length of 152 m at Lowest Astronomical Tide; LAT).
- 8.1.29 The hydraulics of the fish return system (HCF) tunnel are presented in Table 11.
- 8.1.30 The maximum free surface flow reached is 9.5 m s^{-1} (maximum operational flow at the point of maximum incline (13%)). At the interface at Lowest Astronomical Tide (LAT), where the incline is 12%, free surface flow is 9.07 m s^{-1} .
- 8.1.31 The draft of water under maximum operational flow is 220 mm.
- 8.1.32 Flow velocities and draft decrease as operational flow decreases (see Table 11).
- 8.1.33 At maximum operational flow rate, the transit time from the entrance to the fish return system (HCF) and the interface with the flooded section of the tunnel at Lowest Astronomical Tide (LAT) (worst case due to longest non-flooded length) is 17 s.

Table 11: Flow hydraulics for the fish return system (HCF) tunnel

Scenario	Rate (m ³ h ⁻¹)	Free surface flow velocity at 13.7% (m s ⁻¹)	Free surface flow velocity at 12.0% (m s ⁻¹)	Closed conduit flow velocity (m s ⁻¹)	Draft
Maximum operational flow	4536	9.50	9.07	1.82	220
Minimum operational flow	2808	8.27	7.9	1.14	170
2 Unit Outage flow	1728	7.06	6.75	0.69	130

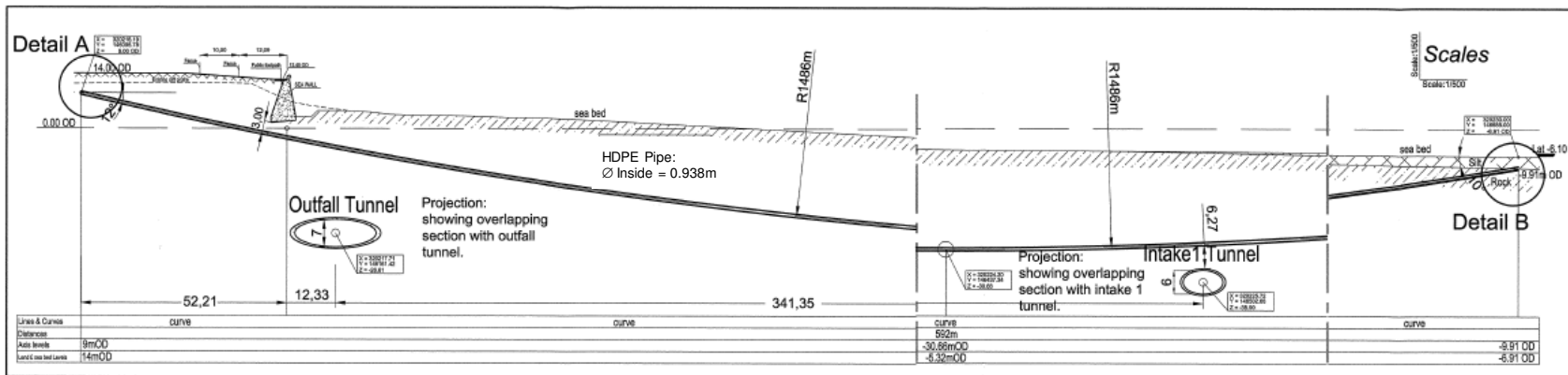

Figure 33: Fish return system (HCF) tunnel

Fish return system (HCF) outfall structure

- 8.1.34 The fish return system (HCF) tunnel terminates with a concrete outfall structure which will act as a diffuser (Figure 34) (Ref [12]).
- 8.1.35 The fish return system (HCF) outfall structure is a pre-fabricated concrete structure. It is 3 m long, 1.55 m deep and 1.34 m wide. The internal diameter of the outfall structure conduit is 938 mm (i.e. the same internal diameter as the fish return system (HCF) outfall tunnel).
- 8.1.36 The fish return system (HCF) outfall structure will be located at a point whereby the fish will be returned to the sub-tidal at all tidal states (i.e. below Lowest Astronomical Tide; LAT). This location is at 320230, 146685.
- 8.1.37 The invert level (exit) of the fish return system (HCF) outfall structure will be at an elevation of -6.71 m ODN. This is approximately 200 mm above the typical silt level at the outfall head location and so will mitigate sediment ingress.
- 8.1.38 During some low tide periods the top section of the fish return system (HCF) outfall structure will be above the tidal level¹⁴, although it should be noted that the outfall invert itself will always be below the tidal level – the minimum water depth at low water on the Lowest Astronomical Tide (LAT) will be 610 mm (see Figure 34).
- 8.1.39 The outfall tunnel will be maintained by ‘pigging’. ‘Pigging’ involves passing a large sphere (the ‘pig’), that has a diameter equal to the tunnels internal diameter, along the length of the tunnel, clearing debris as it does,

¹⁴ An analysis of the previous 25 years tidal data in the Bristol Channel by CEFAS predicts that the tidal water level will drop below the top of the fish return system (HCF) outfall structure average of 24 times per year, with an average duration of 45 minutes and a maximum duration of 2 hours.

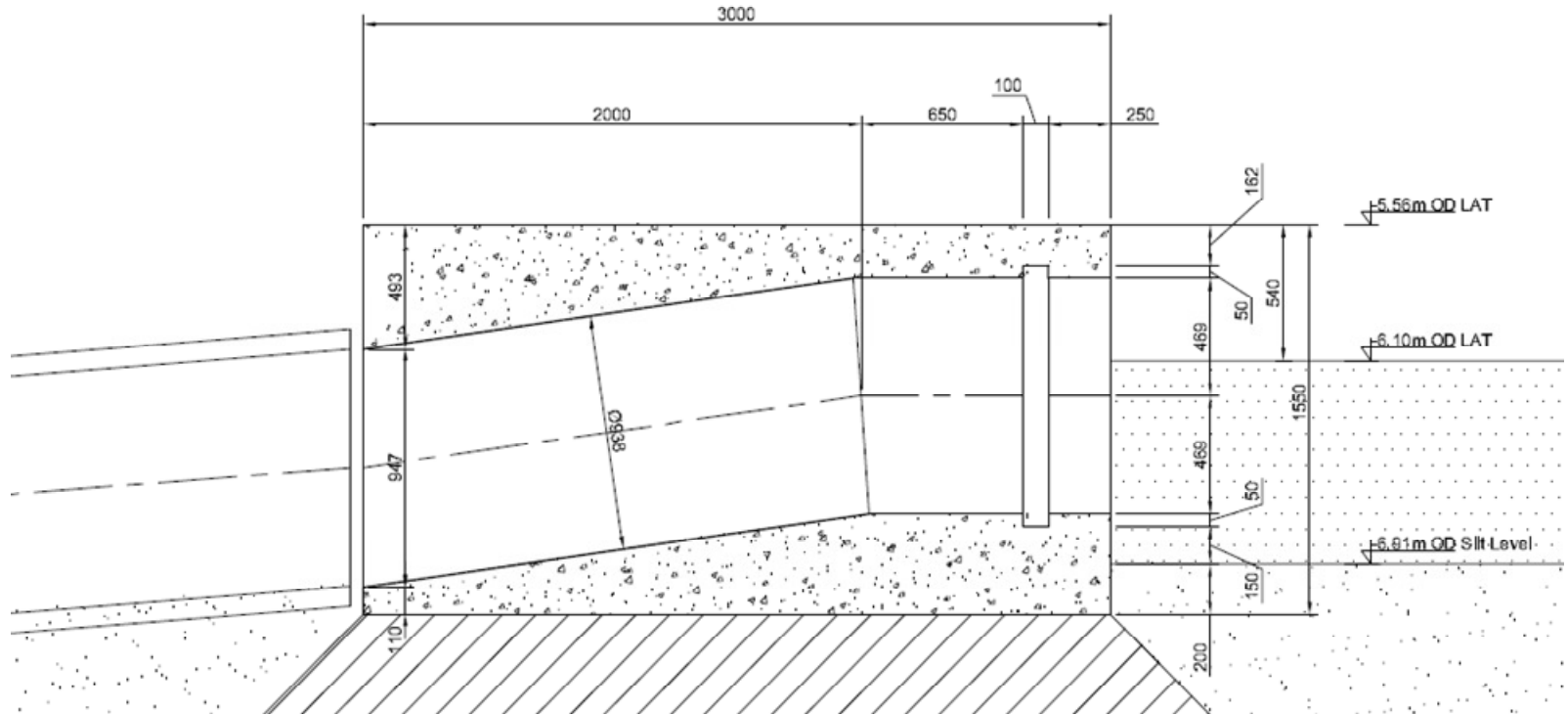

Figure 34: Fish return system (HCF) outfall structure

9 COOLING WATER OUTFALL

9.1 General description

- 9.1.1 As described in Section 4, the two EPR Units at Hinkley Point C will share a common outfall tunnel that extends out into the Bridgwater Bay. The cooling water outfall tunnel terminate with 2 sets of headworks, each set comprising an outfall head on the seabed and a vertical shaft linking the head to the tunnel.
- 9.1.2 No aspect of the cooling water outfall works are designed to mitigate impacts on fish. Water discharged from the main cooling water outfall will not contain fish (or debris) as these will have been filtered out at the cooling water pump house (HP). The water will contain organisms small enough to pass through the 5 mm band and drum screen mesh (including phytoplankton, zooplankton and fish eggs). However, the design of the outfall head has no impact on these entrained organisms.

9.2 Location of outfall

- 9.2.1 Design of the heat sink (the means by which the station loses the heat from its condensers) is an extremely important aspect of system design for nuclear power stations, in terms of both safety and efficiency as well as environmental impacts.
- 9.2.2 From an operational perspective, a number of factors have to be considered when choosing the location of cooling water outfall (many of these are similar to the requirements of the intake headworks). The site should:
- (i) be geologically suitable (i.e. comprises suitable bedrock for construction and is inactive¹⁵ in respect of faulting or tectonic movements);
 - (ii) not cause a hazard to navigation by ships (to minimise risk of impact on the headworks);
 - (iii) be situated in water deep enough to enable stratification, whereby the warm water can rise to the water surface and lose heat to the air as opposed to mixing with the surrounding water;
 - (iv) be sufficiently far away from the associated cooling water intake headworks, so that water discharged from the outfall is not taken in by the intake¹⁶.
 - (v) be as close to the station as possible to reduce the pumping capacity required by the system cooling water system¹⁷.

¹⁵ Even though geologically inactive locations are chosen, the headworks and tunnels are built to be able to withstand earthquakes.

¹⁶ Water discharged by the outfall will be approximately 10° C warmer than ambient, and so if this water is 're-circulated' into the intake it has less cooling capacity than ambient seawater, making the heat sink cooling process less efficient.

¹⁷ The longer the tunnels are, the more friction there is in the system which requires larger pumps to be installed to pump the water.

- 9.2.3 From an environmental perspective, the outfall must be sited such that the warm water discharged (approximately 11°C warmer than ambient) does not adversely affect fauna on the seabed.
- 9.2.4 For HPC, specifically, attention had to be paid to the protected mudflats to the east of the outfall location and the operational Hinkley Point B, which is in close proximity.
- 9.2.5 With all of the above in mind, the cooling water outfall headworks for HPC are approximately 2km offshore north-north-west of the HPC site.

9.3 Outfall Tunnel

- 9.3.1 As stated above, the two EPR units at HPC will share a single, common outfall (see Figure 35) (Ref [1]).
- 9.3.2 One outfall shaft is connected at the very end the tunnel and the other is connected approximately 200 m landward along the tunnel. This duplication is not to provide redundancy should one of the outfall heads become unavailable (as one might expect) but rather due to construction constraints on the maximum diameter of the vertical shafts (meaning that two shafts and outfalls are required to provide the necessary discharge rate).
- 9.3.3 The horizontal alignment of the outfall tunnel remains the same as presented in the DCO. Under exceptional circumstances, for example previously unidentified adverse geological conditions, it is possible that the alignment might need to be altered, but this is not envisaged. Regardless, the intake locations are fixed so, even if the tunnel does need to deviate from the original route / alignment, the tunnel will return to the intended route and terminate at the correct location.
- 9.3.4 The outfall tunnel will have a somewhat different vertical profile to the two intake tunnels and will follow a constant angle of declination top the outfall shafts (Figure 36). The outfall tunnel will pass under the seawall at a depth of approximately -30.0 m ODN, and continue out towards the outfall shafts at a constant decline of -0.3%, which it joins at a depth of approximately -36.0 m ODN (-36.00 m ODN for the southern outfall shaft and -36.26m ODN for the northern outfall shaft).
- 9.3.5 The horizontal and vertical profiles of the outfall tunnel are shown in Figures 35 and 36, respectively (and at A3 in Appendix B)
- 9.3.6 The outfall tunnel will have a finished internal diameter of 7 m.
- 9.3.7 The tunnel will be excavated using an earth pressure balance type- tunnel boring machine (TBM) then lined with reinforced, precast concrete segments, fitted with water proofing gaskets. Because the segments are moulded, they will have a very smooth finish.
- 9.3.8 Under normal operational conditions (two units operating), water will flow at approximately 3.5 m s⁻¹ along the tunnel.

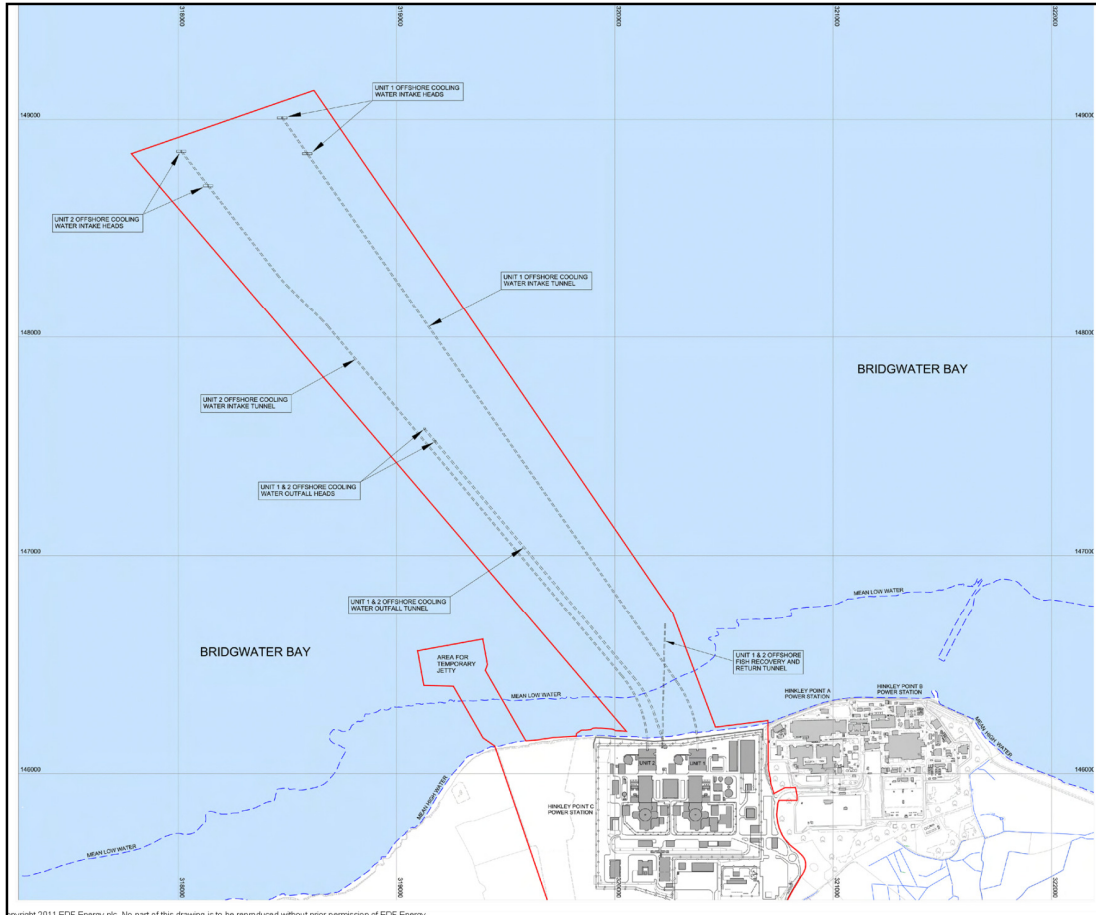

Figure 35: Locations of the intake headworks and intake tunnels (also showing outfall headworks and tunnels and Fish Recovery and Return outfall) [ref: Environmental Statement, Volume 2, Chapter 2, Figure 2.9] [Presented as A3 in Appendix B].

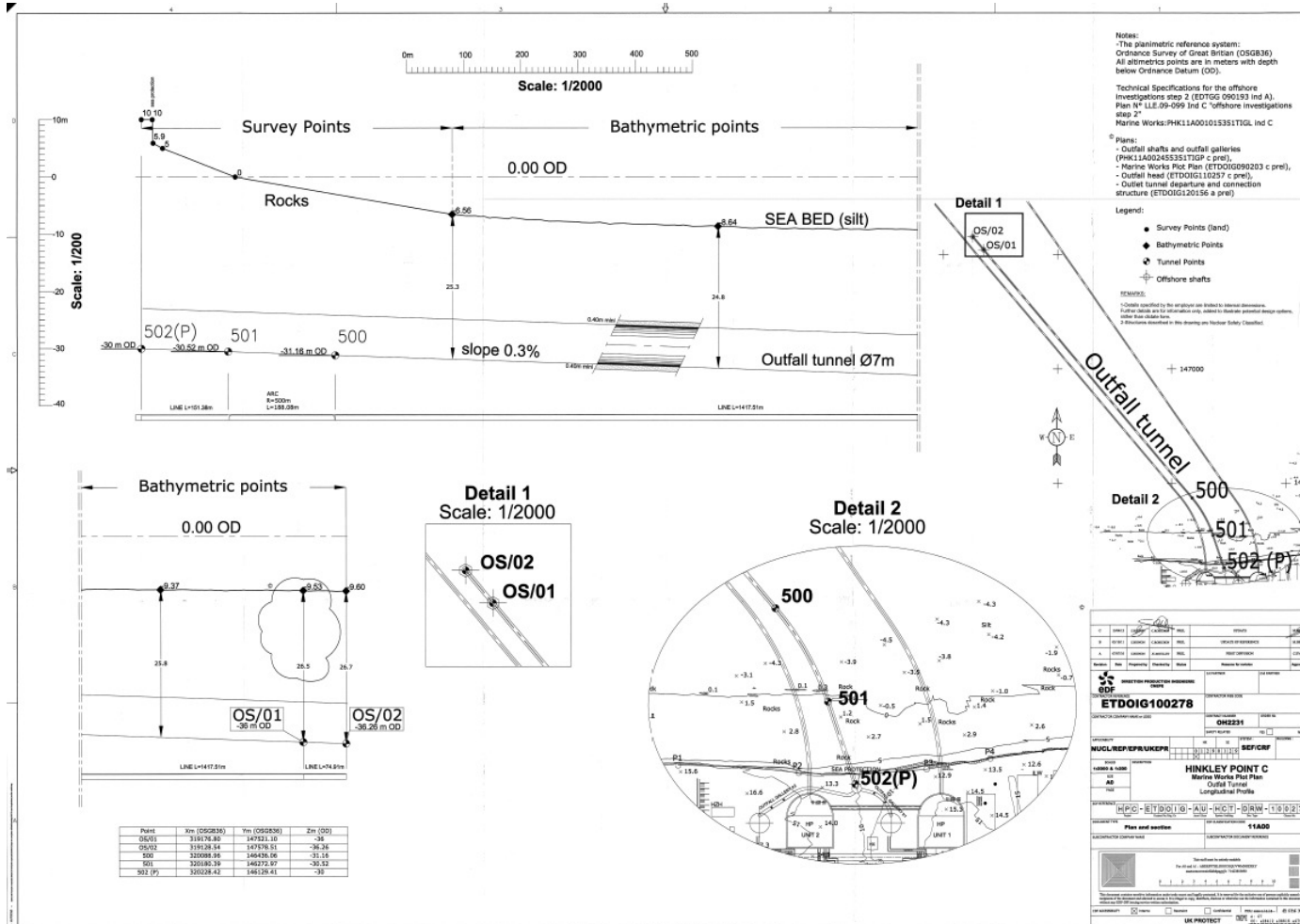

Figure 36: Vertical profile of the cooling water outfall tunnel

9.4 Outfall Shafts

- 9.4.1 The outfall tunnel will be linked to each of the 2 outfall head structures by a vertical shaft. Each shaft will be approximately 30 m deep, the precise depth will be determined by site specific bathymetry and. Each shaft will be 4.6 m diameter.
- 9.4.2 The shafts will be lined with pre-fabricated concrete segments; as they segments are moulded they will have a very smooth finish.

9.5 Outfall Head Structures

- 9.5.1 The common (shared) outfall tunnel has 2 outfall structures, approximately 200 m apart. This spatial separation is to provide redundancy so that the station can continue to operate should one of the individual outfalls become unavailable.
- 9.5.2 The precise locations of the outfall heads are presented in Table 12 , where co-ordinates are presented as 3 points along the axis, running centrally through the structure as shown in Figure 37.
- 9.5.3 The locations are shown in Figure 35

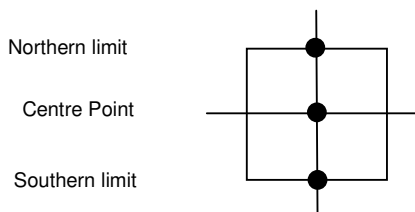

Figure 37: Outfall co-ordinate points.

Table 12: Co-ordinates of the offshore intake heads (see Figure 35)

Outfall	Location	Grid Refer	Latitude	Longitude
Outfall 1 (southern)	Northern Limit	ST 19176 47521	51.221186	-3.1587143
	Centre Point	ST 19176 47526	51.221141	-3.1587131
	Southern Limit	ST 19176 47518	51.221114	-3.1587125
Outfall 2 (northern)	Northern Limit	ST 19128 47583	51.221692	-3.1594143
	Centre Point	ST 19128 47578	51.221647	-3.1594132
	Southern Limit	ST 19128 47575	51.221620	-3.1594125

- 9.5.4 The outfall head design remains identical to that described in the application for development consent Environmental Statement (ES) (Ref [1]).
- 9.5.5 The outfall headworks are nuclear safety classified, meaning they are seismically qualified, and require regular inspection. To allow inspection there is an inspection hatch incorporated into the top of the design.
- 9.5.6 The outfall head itself has a somewhat simple design, being funnel shaped to expel the cooling water at seabed level. The head is wider at the front (outflow side) than at the rear. The aperture for the outflow is split vertically into 2 sections.
- 9.5.7 The outfall head has no bars across the aperture. The flow exiting the outfall head will be sufficient to prevent animals from entering the outfall structure.
- 9.5.8 The outfall head design is presented in Figures 38, 39 and 40. The dimensions are presented in Table 13.



Figure 38: 3 dimensional view of the cooling water outfall structure

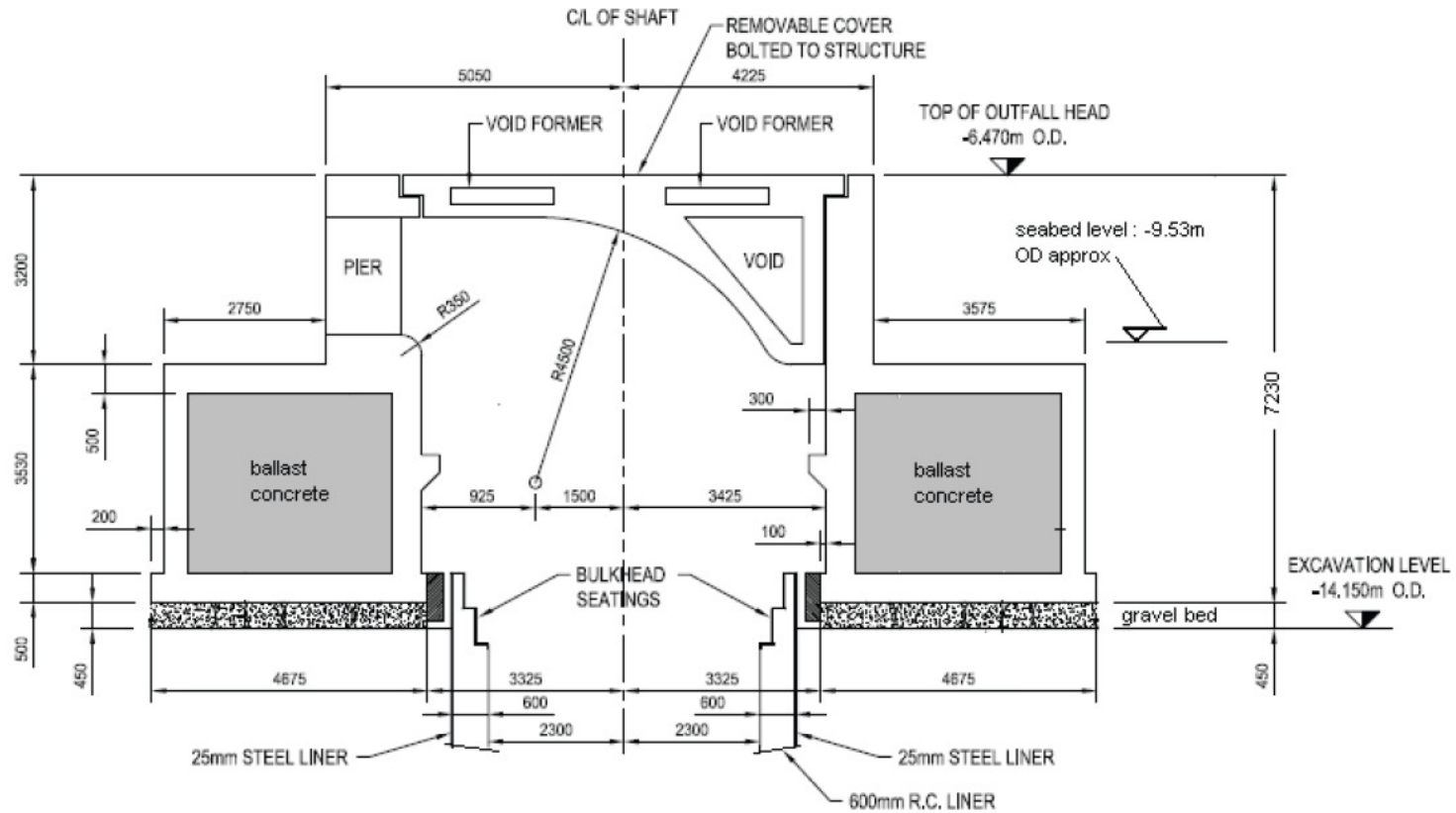

Figure 39: Section through cooling water outfall structure

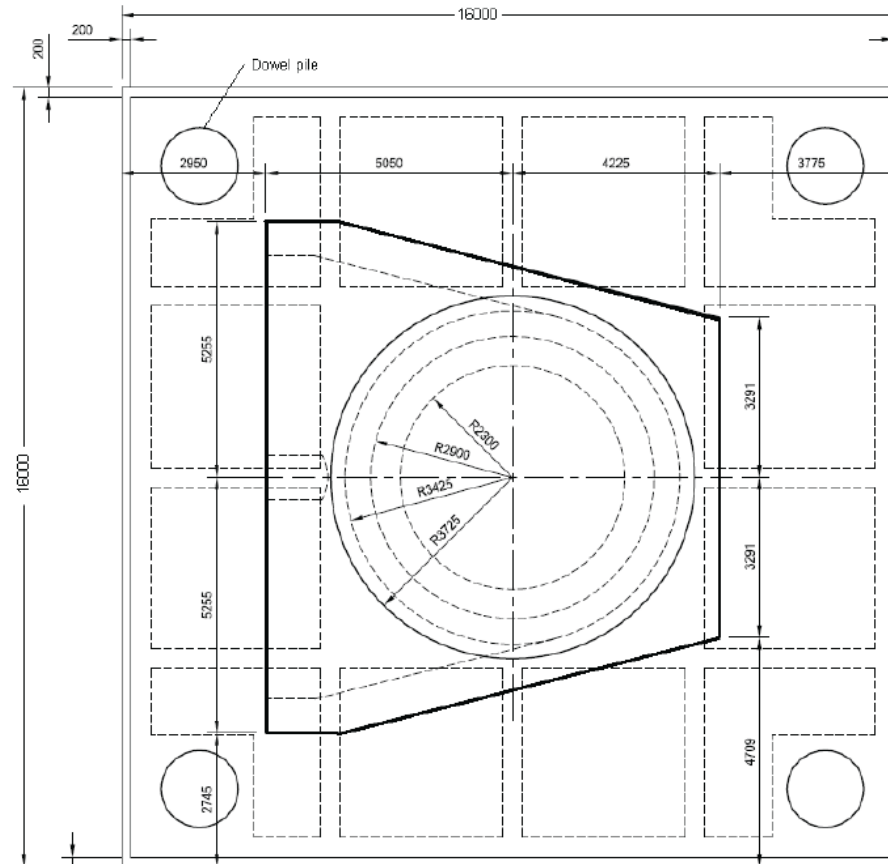

Figure 40: Plan view of cooling water outfall structure

Table 13: Dimensions of the outfall head structures.

Parameter	Dimensions
Overall length	9.26 metres
Width at back	6.58 metres
Height outfall section	3.20 metres
Width at front	10.45 metres

10 COMPLIANCE WITH EA FISH PROTECTION DOCUMENTS

- 10.1.1 The design of the Hinkley Point C cooling water infrastructure in particular, but not limited, to the intake heads and cooling water pump house (HP) filtration equipment, has been modified for fish protection. As explicitly stated in the Development Consent Order (DCO) requirement (CW1), in so far as possible, the design of the fish protection measures has been made to meet recommendations and requirements described in Environment Agency Science and Evidence Reports. These are:
- (i) Environment Agency (2005) *Screening for Intake and Outfalls: a best practice guide*. By Turnpenny, AWH and O’Keeffe, N. Environment Agency Science Report SC030231/SR3. Environment Agency, Bristol UK. [Ref 2]
 - (ii) Environment Agency (2010) *Cooling Water Options for the New Generation of Nuclear Power Stations in the UK*. By: Turnpenny, AWH, Coughlan, J, Ng, B, Crews, P, Bamber, RN and Rowles, P. Environment Agency Evidence Report SC070015/SR3. Environment Agency, Bristol UK. [Ref 3]
- 10.1.2 Although not explicitly specified in DCO Requirement CW1, design of the fish protection measures has also been assessed for compliance with post-DCO recommendations made in Environment Agency (2011) “*Screening at intakes and outfalls: measures to protect eel*” (Ref [4]).
- 10.1.3 The following sections compare the design of the Hinkley Point C fish protection measures with the criteria provided in the three Environment Agency reports. Where recommended criteria are not met by the Hinkley Point C design two things are provided:
- (i) an explanation or justification as to why the recommended criterion cannot be met, which may include reasons of nuclear safety, system hydraulics, physical space and the large tidal range encountered at Hinkley Point C¹⁸; and,
 - (ii) an assessment of how not meeting the criteria may, or may not, affect the ‘fish friendliness’ of the Hinkley Point C cooling water infrastructure design.
- 10.1.4 Technically the term ‘fish recovery and return’ applies from the point in the system where the fish are first recovered (i.e. at the filtration equipment in the cooling water pump house (HP)), but during consultation with the Environment Agency (and others) on the Hinkley Point C fish protection measure it has been acknowledged that in reality any part of the system that the fish travel through needs to be as ‘fish friendly’ as possible to improve the cumulative chance of survival through the system and subsequent return to sea.
- 10.1.5 As with the description of the system itself, the following sections are structured in order that the fish encounter them through the system, from intake to fish return system (HCF) outfall.

¹⁸ The tidal range in the Bristol Channel is the third largest in the world, after the Bay of Fundy and Ungava Bay in Canada, with a 9.6 m difference in height between low tide and high tide at Avonmouth, Bristol.

11 INTAKES

11.1 Intake Location

11.1.1 Compliance with Environment Agency Criteria

11.1.2 Environment Agency guidance (Ref [2]) recommends that consideration should be made of the following points when selecting the location of the cooling water intakes:

- (i) They should be located in an area where the seabed is open and free from obstructions so the abstraction does not affect the ambient flow regime significantly;
- (ii) They should not be located in intertidal or saltmarsh areas, or any other areas where fish might congregate. increases the risk of drawing in juvenile fish;
- (iii) They should not be located in narrow estuaries where migratory fish such as salmonid smolts may migrate in mid-channel; and,
- (iv) They should not be located in fish spawning or nursery areas, including those of both national and local importance.

11.1.3 The Hinkley Point C intakes will be located approximately 3 km offshore from the (south) coast of the Bristol Channel (Ref [1] [13]). The location is in open water and not near any fish spawning or nursery grounds.

11.1.4 Conclusion

11.1.5 The location of the Hinkley Point C intakes is compliant with Environment Agency criteria.

11.2 Intake heads

11.2.1 Compliance with Environment Agency criteria

11.2.2 The intake head can be considered the first line of defence in respect of fish protection, as if it can be designed to minimise fish entrapment the fewer fish need to be recovered and returned to sea.

11.2.3 Fish entrapment at abstraction intakes can be mitigated in several ways intake velocities can be reduced in several ways, the combination of which is a 'low velocity, side-entry' (LVSE) intake design.

11.2.4 Environment Agency guidance (Ref [2]) recommends minimising the velocity at which water enters the intake to provide the fish the best opportunity to swim away.

11.2.5 Environment Agency guidance (Ref [2]) states that "for most power plant intake purposes a design fish-escape velocity (i.e. intake velocity) of 0.3 m s^{-1} will be suitable and meet best requirements". It goes on to state, "Where a different value might be preferable, the guide [i.e. Environment Agency, 2005 (Ref [3])] should be consulted".

11.2.6 The side entry aspect of a Low Velocity Side Entry (LVSE) intake design mitigates fish entrapment in two ways. Firstly, as its name suggests, it abstracts water sideways, as fish are more able to swim away from horizontal currents than vertical ones. Secondly,

by the entry apertures at 90° to the river and/or tidal flow, the velocity of the current is effectively removed (Ref [13]).

- 11.2.7 Hinkley Point C has an LVSE design for its 4 offshore intakes, the first of their kind to be used for a direct-cooled power station.
- 11.2.8 The design of the LVSE for Hinkley Point C started with a basic capped (side-entry) intake and, following computational flow dynamic (CFD) modelling, refinement of the design and further modelling, evolved to the design described in Section 4.3 (Ref [5]).
- 11.2.9 Assessment of the LVSE against the recommended criterion of 0.3m s^{-1} has been made using numerical (CFD) (Ref [5]) and physical modelling (Ref [14]). Selected outputs from the two modelling studies are provided in Appendix B.
- 11.2.10 Performance of the LVSE intake head was assessed against a series of combinations of tidal levels and current velocities chosen to be representative of ‘worst case’ environmental conditions.
- 11.2.11 For each selected water level, two different current velocities were tested corresponding respectively to the mean and extreme (5% exceedance probability) current velocities. Tested environmental conditions are summarised in Table 14, together with their corresponding exceedance probability levels. The water levels are chosen from the lower half of the tide (early flood or late ebb), on the basis that the impact of the structure on local flow patterns will be greater at lower water levels for a given current
- 11.2.12 1.5m s^{-1} is the 95%-ile value for depth-averaged tidal velocities at a depth of 0.0m OD at Hinkley Point (Figure 40) and was, therefore, chosen as a suitable maximum value for the numerical modelling work. Intermediate tidal velocities were also modelled (0.6 and 0.85m s^{-1}) to capture tidal velocities (95%-iles) at other states of the tide (Tables 14 and 15).
- 11.2.13 In the absence of an environmental current, the incoming flow is well distributed along the intake structure and below 0.3 m s^{-1} .

Table 14: Environmental conditions (tidal level determined current velocities) modelled to assess performance of LVSE intake heads (Ref [14]). [LAT = Lowest Astronomical Tide; MSL = Mean Sea Level]

Tidal level (m ODN)	Current velocity (m s^{-1})	Statistic
-6.1 (LAT)	0.0	0
-4.0	0.6	Mean
-4.0	0.9	95%-ile
-2.0	0.85	Mean
-2.0	1.3	95%-ile
0.1 (MSL)	1.0	Mean
0.1 (MSL)	1.5	95%-ile

Table 15: Modelled distribution of approach velocities and flows for the Hinkley Point C intake head at tidal velocities of 0.6 , 0.85 and 1.5 m s^{-1} (Ref [5]).

Intake Velocity Range (m s ⁻¹)	Tide Stream Velocity								
	0.6m s ⁻¹			0.85m s ⁻¹			1.5m s ⁻¹		
	In-Flow (m s ⁻¹)	% of Flow	Cum. %	In-Flow (m s ⁻¹)	% of Flow	Cum. %	In-Flow (m s ⁻¹)	% of Flow	Cum. %
0.1	2.59	8%	8%	1.39	4%	4%	1.15	3%	3%
0.2	4.97	15%	23%	6.65	20%	24%	3.49	10%	13%
0.3	15.21	47%	70%	13.86	43%	67%	14.51	45%	58%
0.4	5.74	18%	88%	4.12	13%	80%	9.85	30%	88%
0.5	3.99	12%	100%	2.86	9%	89%	0.82	3%	91%
0.6	0	0%	100%	3.63	11%	100%	1.15	4%	95%
0.7	0	0%	100%	0	0%	100%	0	0.0%	95%
0.8	0	0%	100%	0	0%	100%	1.53	5%	100%
0.9	0	0%	100%	0	0%	100%	0	0.0%	100%
Total	32.5	100%	100%	32.5	100%	100%	32.5	100%	100%

- 11.2.14 The target intake approach velocity value of 0.3 m s⁻¹ was achieved across around 70% of the intake head aperture at current velocities 0.6 and 0.85 m s⁻¹ and across approximately 60% of the intake head aperture at a tidal velocity of 1.5 m s⁻¹ (Table 15).
- 11.2.15 However, approximately 0.4 m s⁻¹ was achieved across almost 90% of the intake head aperture at tidal velocities of 0.6 and 1.5 m s⁻¹ (80% at 0.85 m s⁻¹); and almost all of the flow entering the intake was at 0.5 m s⁻¹ (Table 15).
- 11.2.16 The physical modelling study largely corroborated the findings of the numerical modelling study. Variations between the two modelling studies were largely accountable to the ways the two sets of data are handled and presented. The physical model provides values for specific points (i.e. each impellor) whereas the numerical modelling averages flows across a defined area.
- 11.2.17 One additional output from the physical model is intake velocities at 0 m s⁻¹, i.e. when the tide is not flowing. At high water at the Mean High Water Spring tidal level, approximately 0.3 m s⁻¹ was achieved over 38% of the intake and approximately 0.4 m s⁻¹ was achieved over approximately 97%.
- 11.2.18 Measurement of the tidal current in the vicinity of the intake locations was made from a bed mounted current meter (Figure 40) (Ref [15]). This recorded current profiles throughout the water column over a whole spring-neap tidal cycle, but at the height corresponding to the of the intake heads current velocities were <0.6 m s⁻¹ for 48% of the time, between 0.6 and 0.85 m s⁻¹ for 22% and between 0.85 and 1.5 m s⁻¹ for 30% of the time.
- 11.2.19 Combining this information from Ref [15] with that provided in Table 15 shows that the target intake velocity of 0.3 m s⁻¹ (or less) will be met (47 + 15 + 8) * 0.48 + (4 + 20 + 43) * 0.22 + (3.5 + 10.7 + 44.6) * 0.30 = 66% of the time over a complete spring-neap tidal cycle.

11.2.20 The same calculation shows that 0.4 m s^{-1} will be achieved 86% of the time, and 0.5 m s^{-1} will be achieved 95% of the time, again, over a complete spring-neap tidal cycle.

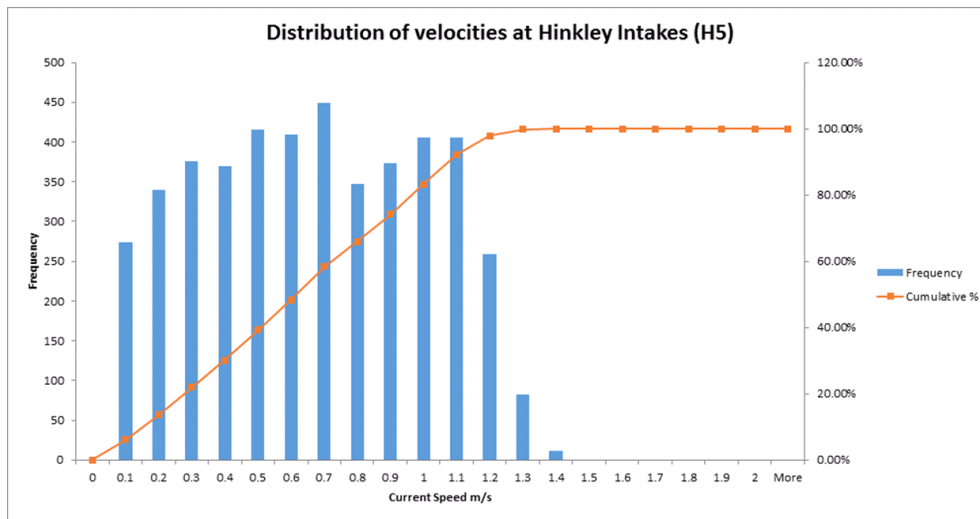

Figure 40: Tidal velocities (average in blue, 95%-ile in red) recorded at the location of the Hinkley Point C intake locations (Ref [15]).

11.2.21 Both models demonstrated that flow varied across the length of the intake structure, with lower intake velocities occurring towards the centre of the intake structure aperture and higher values occurring towards the two ends. This is due to the hydraulics inside the intake head, where the abstracted water is channelled towards the centre of the intake and pass down into the vertical shaft. The introduction of more baffles along the face of the intake head might reduce this variation by increasing the hydraulic resistance (A. Turnpenny, pers comm), however, to do so would reduce the existing baffle and bar spacing and thus increase the risk of clogging.

11.2.22 Should blinding of the intake occur, due to large pieces of debris obscuring the intake opening, intake velocities would necessarily increase because the surface area available for abstraction would decrease.

Justification of Design

- 11.2.23 The Hinkley Point C intakes head was designed to achieve and approach velocity of 0.3 m s⁻¹ along the whole length of the intake all of the time.
- 11.2.24 Numerical modelling demonstrates that the final design will achieve the recommended 0.3 m s⁻¹ for approximately two thirds of the time and that approach velocities will vary along the length of the intake head. NNB GenCo (HPC) Ltd considers that this is the best that can be achieved for a system this large when all constraints are considered.
- 11.2.25 There are two factors that affect the intake velocities: rate of extraction and size of abstraction (intake head) aperture. Rate of extraction is fixed and is constrained by the cooling requirements of the nuclear power station. Size of the abstraction aperture could be increased in one of two ways, namely make the 4 intake heads larger or have more intake heads. The reasons that Hinkley Point C cannot have larger or more intake heads are detailed in Ref [16]. Ref [16] is the assessment of the cooling water intake and outfall design for the heat sink. The assessment detailed in Ref [16] is to demonstrate that the nuclear safety risk related to the current design is As Low As Reasonably Practicable (ALARP).
- 11.2.26 The intake heads are already very large: 43.6 m long, 10 m wide and almost 2.8 m high and are nuclear safety classified; in terms of civil engineering these structures are already very challenging. The intake structures are already considered to be at the limit of constructability and safety classification.
- 11.2.27 Increasing the number of heads in theory would reduce the intake velocities further, but incurs additional issues. Firstly, increasing the number of intakes per tunnel would not result in a uniform reduction in intake velocities across all intakes in any case (due to different tunnel lengths between the intake and the shore) the more intake heads there are, the more the likely variation between their hydraulic performance. Secondly, the additional costs of building and installing additional intake heads, with associated vertical shafts and Acoustic Fish Deterrent system are extremely significant given the limited benefit in terms of fish entrapment. Increasing the number of intake heads is not expected to provide significant gains in terms of reducing fish entrapment.
- 11.2.28 The relevant extract from Ref [16] is presented below:

“The argument regarding intake velocities could be extended to include the three or four intake heads per tunnel options, however in these cases it would become increasingly hard to equilibrate the intake velocity across the multiple intake heads. This would likely result in one intake head drawing more water than the others, which would nullify any environmental benefit gained through these options.”
- 11.2.29 The ALARP assessment justifying the size of the intake heads explains why the heads have no ‘over capacity’ (in respect of intake velocities) to allow for blinding of the intakes. As described at 11.2.22, should significant blinding occur the intake velocities would necessarily increase. Where possible, intakes can be overs-sized to provide contingency for blinding causing increases in intake velocity but, for the reasons described in Ref [16] the Hinkley Point C intakes are as large as they can be.
- 11.2.30 In any case, blinding to the extent that would cause significant increases in intake velocities is not expected. As an example, for blinding to cause a 20% in approach

velocities the intake head would need to be obscured by 20% (i.e. the relationship between approach velocity and surface area is linear). For the HPC design, a 20% reduction equates a reduction from 126 m² to 105 m² - which corresponds to a blinding of the openings over a length of 10m (1/3rd of the useful length of one face) and over all of their height (2m). Blinding on such a scale (i.e. 20 m²) is not expected, and so it is not expected that blinding will have any significant effect on intake velocities. As discussed in Ref [16], perfect equilibration of hydraulic performance between the 2 intake heads is unlikely and so blinding may cause intake velocities to increase over a more localised area as opposed to the cumulative intake area of all 2 intakes.

- 11.2.31 Depending on where, and over what area, blinding occurs, it may actually help to reduce variability in intake velocities along the face of the intake head by increasing the hydraulic resistance locally (A Turnpenny, pers. comm.).
- 11.2.32 The mid-channel location of the intakes means the probability of a significant clogging of the intake screens is very low. In addition, both dense debris on the seabed and debris floated on the surface are avoided by the intake aperture being mid-water (there is a 1 m between the sea bed and intake head, and a 2 m gap between the intake head extreme low sea water level).
- 11.2.33 OPEX from Hinkley Point B confirms that blinding of the HPC intake head is not likely. There are no Condition Reports (CRs) relating to clogging of the intake caisson, which has a bar spacing of 230mm (i.e. closer than the 260mm bar spacing on the HPC intake head) (B Webber, HPB Cooling Water System Engineer, pers comm).
- 11.2.34 OPEX shows that clogging of the forebay coarse screens by seaweed (which have a bar spacing of 75 mm) only happens infrequently, and typically following storms when local wrack is torn off from the littoral and near sub-littoral due to sever wave action. The HPC intake, being 2.9 km offshore, is not expected to experience significantly more intake of storm derived seaweed, indeed it is more likely that it will take in less.
- 11.2.35 Given the location of the HPC intake heads, and the spacing of the bars, the risk of blinding occurring to the extent that would significantly impact fish protection performance of the intake heads is considered negligible.
- 11.2.36 The risk of biological fouling in the HPC cooling water system is considered low. Regardless, biofouling of the intake head is mitigated to some extent by the use of copper-nickel for the bars between the intake head baffles. The risk, therefore, that fouling of the intake head might impact intake head velocities to significantly impact the fish protection performance of the intake heads is considered negligible.
- 11.2.37 There is no means available to detect small alterations in intake velocity; instrumentation cannot be installed at the intake head. On site, the operator would be made aware only of very significant blinding of the intake by increase in head-loss through the system. Avoiding hydraulic head loss is critical to maintaining an adequate cooling water supply and to the safe running of the station. It is normally expected that drifting materials such as fishing nets and ropes will in time become caught on intake bars and these will be removed during planned maintenance. However, for the reasons described above, blinding is not expected to be a significant issue at HPC.

- 11.2.38 The feasibility (and appropriateness) of fitting acoustic cameras to any structures proposed to mount the Acoustic Fish Deterrent (AFD) around the intake heads in order to view the intake heads themselves will be investigated during the design stage of the AFD. A monitoring plan to help optimise the Fish Recovery and Return (FRR) system is required for Development Consent Order (DCO) Requirement CW2; potential monitoring of blinding of the intake heads using acoustic cameras will be considered for that monitoring plan
- 11.2.39 As described in the Development Consent Order (DCO), it is planned that Hinkley point C will be fitted with an Acoustic Fish Deterrent (AFD) System to provide a behavioural cue for fish to swim away from the intake head and thus avoid being entrapped in the first place. The AFD would be more effective for those fish species with good and moderate hearing such as sprat and herring – these species are delicate and not expected to survive impingement on the filtration screens anyway. The Acoustic Fish Deterrent (AFD) system is currently in the very early stages of design and will be discussed through a separate work stream and reported in a subsequent report to inform the discharge of DCO Requirement CW1 (when paragraph (2) is addressed).
- 11.2.40 Although the design of the Acoustic Fish Deterrent (AFD) system is not finalised, the design of the intake heads is. The Acoustic Fish Deterrent (AFD) system is being designed with the intake head design as a fixed constraint (design input parameter).
- 11.2.41 There is no contingency plan should the Acoustic Fish Deterrent (AFD) system and Low Velocity Intake, Side Entry (LVSE) intake heads not work as predicted. The performance of both the Acoustic Fish Deterrent (AFD) system and the Fish recovery and Return (FRR) system will be optimised, where possible, but it is not be feasible to change the intake heads once the station is in operation.
- 11.2.42 Impact Assessment
- 11.2.43 From an environmental perspective, the fact that 0.3 m s^{-1} is only achieved for two thirds of the time is not considered significant for Hinkley Point C.
- 11.2.44 Firstly, and significantly, the assessment of fish impingement used in the Hinkley Point C Environmental Impact Assessment (EIA) and Habitats Regulations Assessment (HRA) took no account of intake velocity because there are no data on which to make a comparison. Impingement comparisons were scaled up from the fish impingement data at Hinkley Point B (HPB) which does not have a low velocity intake. Similarly, efficiency of the Acoustic Fish Deterrents (AFD) and Fish Recovery and Return (FRR) systems at other direct-cooled power stations but, again, these do not use low velocity intakes. Therefore, the fish impingement predictions for Hinkley Point C assume the same intake velocities as those of Hinkley Point B (with the efficiency of operating AFD systems, such as Doel). The full fish impingement datasets and predictions are presented in Ref [17].
- 11.2.45 Regardless, swimming speeds of key fish species at Hinkley Point have been assessed in respect of their swimming speeds (the defining parameter as to whether the fish can swim away from the intake).

- 11.2.46 Following the development of the final intake head design with the velocity characteristics described above, a fish risk assessment was undertaken to estimate the proportion of fish that are expected to have the swimming capacity to escape capture at the intake head (Ref [18]). The study involved three stages:
- (i) Extracting the relevant hydraulic data from the intake modelling studies, to show the probability distributions of different velocity values. This was carried out in all cases for the maximum likely tidal crossflow velocity of 1.5 m s^{-1} and for intermediate velocities of 0.60 and 0.85 m s^{-1} ;
 - (ii) Selecting a subset of key fish species (shad, cod, whiting, sole, bass, herring) from the list of those regularly impinged on the Hinkley Point B intake screens and extracting data from year 2009 Comprehensive Impingement Monitoring Programme (CIMP) on numbers caught and their length-frequency distributions. These are the key species which will rely wholly or in part upon the Acoustic Fish Deterrent (AFD) combined with low velocities;
 - (iii) Computing swimming performance versus fish length for each species, which was then used to estimate the proportion of the Hinkley Point B 2009 catch (baseline case) that would potentially be capable of escaping intake velocities associated with the various designs. As water temperature also affects fish swimming performance, the analysis took account of seasonal temperature variations using quarterly temperature and fish catch data. Average swimming performance values were used to predict the fish catch relative the Hinkley Point B baseline case; 90%-ile swimming speeds were used to represent a more pessimistic case based on the weaker swimmers within the population and finally an intermediate 'mixed' swimming ability case was calculated
- 11.2.47 Table 16(a) presents findings based on the assumption that all fish can swim at or above the average predicted swimming ability. It is shown that, across all six species, the Hinkley Point C intake design reduces potential catches to less than a quarter (18.4 to 24.4%) of the baseline (based on Hinkley Point B impingement data).
- 11.2.48 The Hinkley Point C intake design achieves this good performance over the full range of tidal velocities tested, up to 1.5 m s^{-1} . Taking a very pessimistic case, based on all fish only achieving 90%-ile swimming speed values, the Hinkley Point C intake design is predicted to reduce catches to between 56.1 and 64.7% (Table 16(b)).
- 11.2.49 It might be argued that the swimming ability assumption for Table 16(a) is over-optimistic, while that for Table 16(b) is unduly pessimistic. Therefore, Table 16(c) is provides an intermediate (but still pessimistic) condition derived by combining the mean and 90%-ile. Under this set of assumptions, the HPC intake design is predicted to reduce overall catch to 41.6-47.8% (Table 16(c)).

Table 16(a): Mean Swimming Performance

Tidal Velocity	% of Hinkley Point B Fish below Escape Velocity						
	Shad	Bass	Sole	Whiting	Herring	Cod	All Six

$m s^{-1}$							Species
0.6	14.1%	4.7%	10.8%	21.1%	8.7%	17.6%	18.4%
0.85	21.0%	8.2%	17.9%	27.0%	16.5%	22.9%	24.4%
1.5	17.8%	7.9%	15.9%	26.6%	10.3%	24.5%	23.8%

Table 16(b): 90%-ile Swimming Performance

Tidal Velocity $m s^{-1}$	% of Hinkley Point B Fish below Escape Velocity						
	Shad	Bass	Sole	Whiting	Herring	Cod	All Six Species
0.6	48.0%	27.8%	44.0%	60.2%	28.38%	60.0%	56.1%
0.85	48.8%	31.0%	46.4%	61.1%	31.5%	60.2%	57.3%
1.5	57.3%	34.7%	51.3%	69.0%	38.5%	68.8%	64.7%

Table 16(c): Mixed Swimming Performance

Tidal Velocity $m s^{-1}$	% of Hinkley Point C Fish below Escape Velocity						
	Shad	Bass	Sole	Whiting	Herring	Cod	All Six Species
0.6	36.3%	23.5%	33.0%	44.6%	25.7%	42.8%	41.6%
0.85	40.0%	26.5%	37.5%	47.9%	30.8%	45.5%	45.1%
1.5	41.8%	27.8%	38.5%	50.9%	30.6%	49.8%	47.8%

- 11.2.50 Sprat (*Sprattus sprattus*), not designated a protected species but the most abundant fish species impinged at Hinkley Point B, were not included in the original assessment presented in Table 16. However, during consultation on fish protection measures at Hinkley Point C, the Environment Agency requested information on the swimming performance of sprat in relation to the Hinkley Point C intake heads.
- 11.2.51 Impacts of not achieving $0.3 m s^{-1}$ at Hinkley Point C are not considered important for sprat (Ref [19]).
- 11.2.52 Sprat have a maximum sustainable ('critical') swimming speeds of 10-12 (average 11) body lengths per second were recorded, for example, juvenile sprat of 29-48 mm standard length have swimming speeds of $32 - 53 cm s^{-1}$. Adult sprat of c. 12 cm in length can swim at a maximum sustainable speed of $60 cm s^{-1}$.
- 11.2.53 Assuming sprats to be randomly distributed in the intake approach flow, 89 -90% would experience intake velocities of $\leq 0.5 m s^{-1}$, i.e. within their maximum sustainable

swimming speeds. In turn, 95% of these fish would be larger than 45 mm and therefore would be able to exceed this swimming speed, hence it is likely that <1% would be unable to achieve the necessary sustainable swimming speeds. Based on this information only a very small proportion of the sprat population, comprising smaller 0-group individuals, would lack the swimming ability to escape the intake velocities, as modelled for the HPC intakes. These numbers are not environmentally significant.

- 11.2.54 Three other species of protected conservation status recorded at Hinkley, the eel (*Anguilla anguilla*) and the lampreys *Petromyzon marinus* and *Lampetra fluviatilis*, should not be included in this type of analysis. The response of these species to intake screening is known to be purely tactile and therefore their swimming ability is only relevant where intake bar spacing is small enough to assure physical contact, viz. at <30mm spacing. The protection of eel, lampreys, and of other weakly swimming species such as crustaceans, therefore relies entirely upon the Fish Recovery and Return (FRR) system.
- 11.2.55 Conclusion
- 11.2.56 The Hinkley Point C intake heads are predicted to achieve an approach velocity of 0.3 m s⁻¹ 66% of the time. Although this is not entirely compliant with the 0.3 m s⁻¹ criterion recommended by the Environment Agency, the Hinkley Point C intake heads are still considered acceptable as they achieve 0.4 m s⁻¹ for 86% of the time and 0.5 m s⁻¹ for 95% of the time, which are considered to be protective of fish species likely to be entrapped.
- 11.2.57 The impact assessment for the Hinkley Point C power station (Ref [1]) took no account intake velocity and so the assessment results remain valid.
- 11.2.58 It is considered that the Hinkley Point C intakes heads are already at their maximum size, and assessment (As Low As Reasonably Practicable, ALARP; Ref [16]) has shown that more intake heads is not appropriate.

12 INTAKE SHAFTS AND TUNNELS

12.1.1 Compliance with Environment Agency Criteria

12.1.2 The Environment Agency provides no specific criteria or recommendations for the design and effects of the intake tunnels (or shafts) (Ref [2] [3]). However, as described earlier, it has been acknowledged that in reality any part of the system that the fish travel through needs to be as 'fish friendly' as possible to improve the cumulative chance of survival through the system and subsequent return to sea.

12.1.3 Specific topics of interest raised during consultation were:

- (i) Impacts of the pressure change experienced by fish as they rapidly descend the intake shafts;
- (ii) Potential for abrasion on the shaft and tunnel walls;
- (iii) Turbulence experienced in the tunnel
- (iv) Potential for fish to swim against the current (positive rheotaxis) leading to exhaustion;

12.1.4 **Pressure Change**

12.1.5 When the fish travel from the intake location in to the intake tunnel, they will descend approximately 30 m. This is equal to an increase in pressure of 3 bar. Those fish with cavity species, in particular swim bladders (such as sprat and herring) experience rapid compression of those species more quickly than they can adjust. As the fish travel along the tunnel they are unlikely to have time to adjust their swim bladders to account for this change (A. Turnpenny, pers comm). When they arrive at the end of the tunnel they again experience a pressure change, this time a reduction in pressure, as the tunnel rises towards the surface for entry into the forebay (HPF).

12.1.6 Rapid decreases in pressure are potentially damaging for fish that maintain the volume of their body cavities, because the air expands (or contracts) rapidly (usually more quickly than the fish can compensate) potentially causing damage, or even rupturing, of the cavity. Cavities that are not regulated do not suffer in the same manner because any air simply compresses and expands according to ambient pressure.

12.1.7 Pressure data for Hinkley Point C are:

- (i) Inlet tunnel diameter = 6m
- (ii) Maximum flow through tunnel = $70 \text{ m}^3 \text{ s}^{-1}$
- (iii) Water speed in inlet tunnel = 2.3 m s^{-1}
- (iv) Hence, max. rate of pressure change in vertical riser is $2.1 \text{ m WG s}^{-1} = 0.21 \text{ bar s}^{-1}$
- (v) Maximum inlet tunnel depth = -34 m ODN
- (vi) Maximum water depth = +15 m ODN
- (vii) Maximum pressure in inlet tunnel= $+34 + 15 = 49 \text{ m} = 49 \text{ m WG} = 4.9 \text{ bar}$

- 12.1.8 The effects of pressure changes on fish have been investigated. The principal effect is on the swim bladder, which changes volume according to Boyle's Law. Thus a doubling of pressure will mean a halving of swim bladder volume, and vice versa, but there can be other effects. In the latter case, over-expansion beyond the swim bladder's natural elasticity can cause the swim bladder to rupture. Ref [2] describes the issue as follows (Section 6.1.3, p92):
- “Gadoid fish such as whiting (Merlangius merlangus) and pout (Trisopterus luscus), which regulate swimbladder volume by vascular exchange (known as “physoclists”) as opposed to by gulping and venting air via the gut (“physostomes”), are particularly susceptible. At Sizewell B, more than a third of whiting and pout collected from the screens were found to have ruptured swim bladders. While swim bladder injuries will heal within a few days (Turnpenny et al. 1992), loss of swimbladder function in the meantime may affect functions like buoyancy, balance and hearing, potentially putting fish at greater risk of predation. Station designs most likely to cause pressure effects of this kind are those in which the CW tunnels descend deep below the water surface, so that fish are exposed to rapid depressurisation as they are brought back up to the surface and out onto the screens. Under these conditions, outgassing of the body fluids can also occur, causing symptoms similar to “the bends” in humans.”*
- 12.1.9 The swimbladder is found only in teleost fish and not in elasmobranchs (sharks, rays, dogfish) or lampreys. Some teleost species such as the mackerel (Scombridae) lack a swimbladder, while flatfish and other species of epibenthic habit have only a vestigial and non-functional swimbladder.
- 12.1.10 Within the teleost species possessing a swimbladder, a distinction can be made between those with a ducted connection between the swimbladder and the external water (known as physostomes), and those with a sealed swimbladder, whose volume can only be modulated slowly by vascular gas exchange (physoclists). This limitation makes physoclists vulnerable to rapid pressure reductions, a halving of pressure for example causing a doubling of gas volume (Boyle's law) and associated expansion of the swimbladder often causing tissue to rupture. Rupture has been shown to be less likely if it is a rapid transient, e.g. associated with hydroelectric turbine passage, as tissue elasticity provides a shock-absorber, whereas protracted (several seconds or more) swimbladder expansion can cause the tissue to tear. Examples of physostomes include the cod family (Gadidae) and bass (*Dicentrarchus labrax*). Physostomes on the other hand can vent gas to the exterior instantly if the swimbladder volume changes rapidly, making them less susceptible to barotrauma and include e.g. , Salmonidae, herring, sprat and shads (Clupeidae). Eels have a hybrid of the two systems and hence are able to vent the swimbladder. [A. Turnpenny, pers. comm]
- 12.1.11 Examination of fish that have passed through tunnel systems at power stations often reveal, notably swimbladder rupture in a proportion of physoclist fish and evidence of gas embolisms in eyes of clupeid fish. The effect of descending a tunnel is to increase the hydrostatic pressure. This causes the gas-filled organs compress and is not injurious, although buoyancy may be affected. Rising back to the starting depth at the onshore end of the tunnel simply restores the swimbladder volume and again should not lead to injury. The risk of pressure-related injury is therefore most likely related to differences between the original acclimation pressure of the fish (based on the depth

from which they were drawn into the intake) and atmospheric pressure as fish are lifted from the water by the fine screens. As an example, if the fish's acclimation depth was 10 m (1 bar pressure due to water + 1 bar atmospheric = 2 bar absolute), bringing the fish to atmospheric pressure (1 bar absolute) would halve the pressure and double the swimbladder gas volume, potentially rupturing the swimbladder in a physoclist. Hence the depth of the tunnel *per se* should not affect barotrauma risk.

- 12.1.12 Environment Agency best practice (Ref [2]) gives indicative survival rates of fish collected from drum or band screens based at studies at power stations including Sizewell B and Le Blayais (Gironde Estuary, France). Both stations have offshore intakes with deep tunnels and the recorded survival include any effects related to pressure change. Estimates of post-impingement survival in the Hinkley C FRR system are based on these figures and, therefore, already take into account pressure-related effects in the tunnels and forebay on fish survival.
- 12.1.13 No mitigation for this effect is possible (A. Turnpenny, pers. comm.).
- 12.1.14 Impact Assessment
- 12.1.15 For Hinkley Point C, the intake tunnel will descend to a maximum depth of 34 m below ODN, giving a maximum submersion of 49 m at Highest Astronomical Tide (HAT). Passage of a fish through the tunnel to the forebay (HPF) at Hinkley Point C be at a velocity of approximately 2.3 m s^{-1} and therefore will take around 27 minutes. The depth change is more realistically 39 m for a fish drawn from the intake opening level to the bottom of the inlet riser, which implies a hydrostatic pressure change of up to 3.9 bar; but when ascending the onshore pumphouse riser and then lifted out by the drum screens into air, via a total of up to 49 m of water column, the pressure reduction over this rise will be up to the full 4.9 bar. These are relative pressures. At a starting point of 10 m water depth, the fish is experiencing a pressure of 2 atmospheres (2 bar absolute) and when it is lifted out through the water surface it is at 1 bar absolute (ignoring changes in barometric pressure of the atmosphere). From Boyle's Law the swimbladder volume would double under these conditions under perfect elasticity, but since they are not perfectly elastic there is a risk of rupture.
- 12.1.16 Not all fish species are of interest in terms of impacts from pressure change for cooling water intakes.
- 12.1.17 Pelagic species, such as herring and sprat, experience significant scale loss when they are impinged on the filtration screens (band and drum screens) and as a result most die. This assumption is made in the Hinkley Point C impact analysis (Ref [17]). The impacts of pressure change on these species are, therefore, not relevant.
- 12.1.18 Epibenthic species such flatfish (e.g. plaice and sole) have a vestigial swimbladder and do not show signs of pressure damage.
- 12.1.19 Eel, have a swimbladder that vents to the gut and are tolerant of pressure change and so are also not expected to be affected.
- 12.1.20 Gadoids (cod and whiting) are the species potentially most affected by pressure change. Figure 41 shows unpublished results from trials on a Thameside power station,

where maximum immersion depth was around 40 m. Fish were collected and retained in tanks for 24 h before being euthanized and dissected to examine swimbladder damage. Around 30% of gadoids showed swimbladder damage, similar to results reported for Sizewell ‘B’ (see 12.1.8).

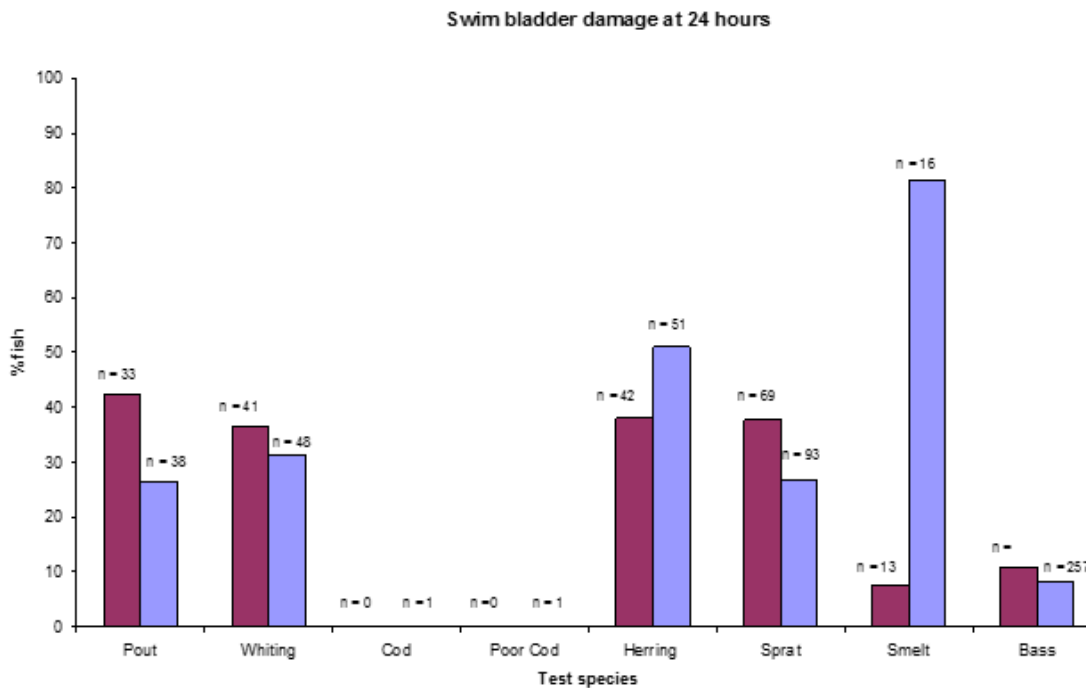

Figure 41: Percentage of impinged fish exhibiting swimbladder rupture when held and examined 24 h after capture at a Thameside power station. The two different colours represent different dates on which samples were collected.

12.1.21 Pressure impacts on gadoids at HPC are likely to be similar to those reported at other stations (see 12.1.8 and 12.1.20).

12.1.22 In terms of the Hinkley Point C Environmental Impact Assessment (EIA) two factors were taken into account:

- (i) Gadoids demonstrate a reasonable response to Acoustic Fish Deterrent (AFD) systems: around 45% are predicted to be deflected; Ref [17].
- (ii) Survival through the Fish Recovery and Return (FRR) system assumed a survival rate of 50% and this incorporates potential impacts from pressure change.

12.1.23 Conclusion

- 12.1.24 Exposure to pressure change is an inevitable part of travelling through the cooling water circuit of direct-cooled power stations, especially as the more significant component is when fish are removed and elevated from the water at the fine filtration (CFI) screens.
- 12.1.25 Not all fish species are susceptible to pressure change though, and at Hinkley Point many of those species that are susceptible would either be deflected by the planned Acoustic Fish Deterrent (AFD) system or not survive impingement on the screens anyway (i.e. sprat and herring).
- 12.1.26 Furthermore, several of the key species predicted to be impinged at Hinkley Point C are not susceptible to pressure change – this includes flatfish (plaice and sole) and eel.
- 12.1.27 Gadoids (cod and whiting) are reported to be susceptible to pressure change. However, a good proportion (approximately 45%) of the gadoids at Hinkley Point C would be deflected by the planned Acoustic Fish Deterrent (AFD) system, and it has been assumed that only 50% of those gadoids that do get impinged will survive – this survival rate includes potential mortalities from pressure-related injuries.
- 12.1.28 The Hinkley Point C impact assessment, therefore, adequately includes the potential impacts of pressure change.

12.1.29 **Abrasion and Turbulence in the Tunnel**

- 12.1.30 The intake (and outfall tunnel) will be lined with prefabricated, concrete segments. The surface finish of the tunnels will be extremely smooth due to the fabrication process, whereby each segment is cast in a steel mould (absolute roughness coefficient for the segmental lining is approximately 1 mm; see Figure 42). Each tunnel ring will be 1.5m long.
- 12.1.31 Joints between tunnel segments are 32 mm wide and sealed with grout. The grout will be finished approximately 40 mm below the interior surface of the tunnel. This is a function of TBM and cannot be mitigated; the joint is small and not expected to affect fish travelling through the tunnel.
- 12.1.32 Biological fouling, which could lead to a rougher surface, is not expected to occur to any significant degree in the intake tunnels. It is understood that the environmental conditions in the Bristol Channel at this point, in particular very high turbidity and low suspended organic matter, are not conducive to fouling organism establishing. In the intake tunnels in particular, flow rates are also very high (approximately 2.0 m s^{-1}) which will also serve to prevent settlement but also potentially cause suspended particulate matter to cause minor scour sufficient to prevent settlement.



Figure 42: Smooth finish of a typical moulded tunnel lining segment.

- 12.1.33 Flow in the tunnel will necessarily be turbulent due to the sheer size of the tunnel and volume of water being extracted.
- 12.1.34 Virtually all pipes and tunnels on an industrial scale will always non-laminar: for a tunnel to be in true laminar flow the water would have to be almost stationary. For example, to achieve laminar flow conditions with sea water at 12°C in a 6m diameter tunnel flow velocity would need to be only 0.005 m s⁻¹. At Hinkley Point C the flow velocity through the tunnel will be approximate 2 m s⁻¹.
- 12.1.35 The Reynolds number¹⁹ for the flow through the Hinkley Point C intake tunnels is around 11,000,000.

¹⁹ Reynolds number is a dimensionless quantity in fluid dynamics that is used to help predict the behaviour of fluids. It is a guide as to what point flow transforms from laminar to turbulent flow and is used to upscale from models to real-world scenarios

- 12.1.36 Impact Assessment
- 12.1.37 The internal surface of the intake tunnels will be smooth, due to both the smooth, moulded surface of the lining segments and the lack of biological fouling.
- 12.1.38 Abrasion is not expected to be an issue at Hinkley Point C, particularly for gadoids, flatfish and eels. The more physically sensitive species (such as sprat and herring) are not expected to survive impingement on the fine filtration system (CFI) screens anyway (and will be mitigated by the Acoustic Fish Deterrent (AFD) system).
- 12.1.39 As with pressure effects (see Section 12.1.12), abrasion impacts will be included cumulatively in the Environmental Impact Assessment as it would be manifest in Fish Recovery and Return systems elsewhere used to inform that assessment.
- 12.1.40 The precise impacts of turbulence in the intake tunnel are not known but, because all industrial-size abstraction tunnels are turbulent, any potential impacts of turbulence will also be manifested in fish survival through other sites.
- 12.1.41 Abrasion impacts will be included cumulatively in the Environmental Impact Assessment as it would be manifest in Fish Recovery and Return systems elsewhere used to inform that assessment. The long length of the Hinkley Point C intake tunnels is acknowledged, but there is no evidence available with which to make a site specific assessment for Hinkley Point C.
- 12.1.42 Under normal conditions, given that the vast majority of fish not be able to maintain their position against the tidal and river flows (i.e. exhibit positive rheotaxis) in the estuary for much of the tidal cycle (e.g. Ref [15] states that tidal velocity is $> 0.6 \text{ m s}^{-1}$ for more than 50% of the time, which could not be maintained by many fish) it might be assumed that they would not attempt to do so in the cooling water intake tunnel either. However, the change in pressure (see Section 12.1.4) fish may become disorientated, or exhibit an escape response, and start swimming against the current (exhibit positive rheotaxis). If this were the case, these fish might be prone to exhaustion due to swimming against a current of approximately 2.3 m s^{-1} .
- 12.1.43 There are no published data on the swimming behaviour of fish in intake tunnels, presumably due to the intrinsic difficulties in monitoring in such environments. From a theoretical point of view, fish have a natural tendency, mediated by the optomotor response, to avoid displacement in a flow. This rheotaxis is informed mainly by visual response but also to some extent a tactile response with the bed. It is considered extremely unlikely that entrapped fish will swim against the current in the main tunnel, because it will be dark, very turbid and the averaged instance from the tunnel walls will be large, so reference points will be limited. (A Turnpenny; pers. comm).
- 12.1.44 Whilst speculation can be made about fish behaviour (as above), therefore, assumptions must be caveated accordingly. A precautionary assessment would, therefore, suggest that fish might not act as inert particles, simply going with the flow, but may actively swim against (or with) the current.
- 12.1.45 However, whilst position maintenance behaviour (positive rheotaxis) would increase transit time through the tunnel (if it were to occur), there is no means to assess how the

extra energetic expenditure might affect survival of the fish through the remainder of the Fish Recovery and Return (FRR) system.

- 12.1.46 In reality, as long as the fish are not suffering directly from exhaustion, fatigue would mean that these fish are likely to arrive on the fine filtration (CFI) system screens more quickly to facilitate recovery and onward transmittal through the Fish Return (HCF) system and back to sea. Once fish are entrapped in the system, the intention is to recover them as quickly as possible and so rapid presentation onto the screens is considered beneficial.
- 12.1.47 Given the location of the offshore intakes it is unlikely that fish behaviour can be monitored. Although tagged fish could be released, the likely success of them entering the system is low. Furthermore, there are health and safety concerns about works very near to the intake heads when the station is operating at full power.
- 12.1.48 Conclusion
- 12.1.49 Abrasion of fish is not expected to be significant.
- 12.1.50 The impacts on entrapped fish of turbulence on the Hinkley Point C cooling water intake tunnels is not known, but turbulence impacts have been included in the cumulative assessment made for the Environmental Impact Assessment.
- 12.1.51 It is considered extremely unlikely that fish will try to swim against the current in the intake tunnel. A precautionary assessment would allow for fish transit times through the intake tunnel to include an element of positive rheotaxis, thereby potentially increasing transit times and leading to fatigue (or exhaustion) of the fish. However, there are no data on this on which to make an assessment.
- 12.1.52 The Hinkley Point C impact assessment, therefore, adequately includes the potential impacts of tunnel passage, albeit it a site specific assessment for the long intake tunnels has not been possible due to lack of suitable evidence.

13 FOREBAY (HPF)

13.1.1 Compliance with Environment Agency Criteria

13.1.2 The Environment Agency provides no specific criteria or recommendations for the design of the forebay (HPF) (Ref [2] [3]). However, as described earlier, it has been acknowledged that in reality any part of the system that the fish travel through needs to be as 'fish friendly' as possible to improve the cumulative chance of survival through the system and subsequent return to sea.

13.1.3 Specific topics of interest raised during consultation were:

- (i) Power dissipation on arrival into forebay (HPF);
- (ii) Hydraulics and shear stress within the forebay (HPF);
- (iii) Residence time in the forebay;
- (iv) 'Lip' at exit of forebay into screen well

13.1.4 Justification of design

13.1.5 The forebay (HPF) performs a critical role in the cooling water system of a direct-cooled power station, namely acting as a reservoir to allow the transition from fast turbulent flow along the intake tunnels to a steady, non-turbulent flow for entry into the Cooling water pump house (HP) filtration equipment.

13.1.6 By design, therefore, the forebay (HPF) experiences quite rapid changes in hydraulics.

13.1.7 At Hinkley Point in particular, because of the high suspended particulate loading of the estuarine water, the design had to be cognisant of flow rates through the forebay (HPF). Indeed, the original semi-circular design proposed at the time of the Development Consent Order (DCO) application has been found to be too susceptible to siltation and the forebay (HPF) now has a smaller, rectangular design.

13.1.8 As the forebay (HPF) performs a critical, functional role, its meeting its functional requirements must supersede considerations of fish protection: if the forebay (HPF) cannot perform its necessary role due to fish protection constraints then there can be no power station.

13.1.9 However, where, the forebay (HPF) has been assessed for hydraulic performance in respect of impacts on fish and, where possible, the design will be optimised to improve fish protection.

13.1.10 For information, a full comparison between the two different options for the revised design has been made (Refs [20] [21]) but only the relevant parts of the assessment are reported in the following section.

13.1.11 The floor of the screen wells is elevated above the floor of the forebay by approximately 1m (see Figure 12 and 43). This serves 2 purposes:

- i) It creates a slight acceleration of flow as the water enters the screen well and through the screens; and

- ii) It prevents sediment that has settled onto the forebay floor from being drawn into the screen well and onto the screens (where it could create clogging).

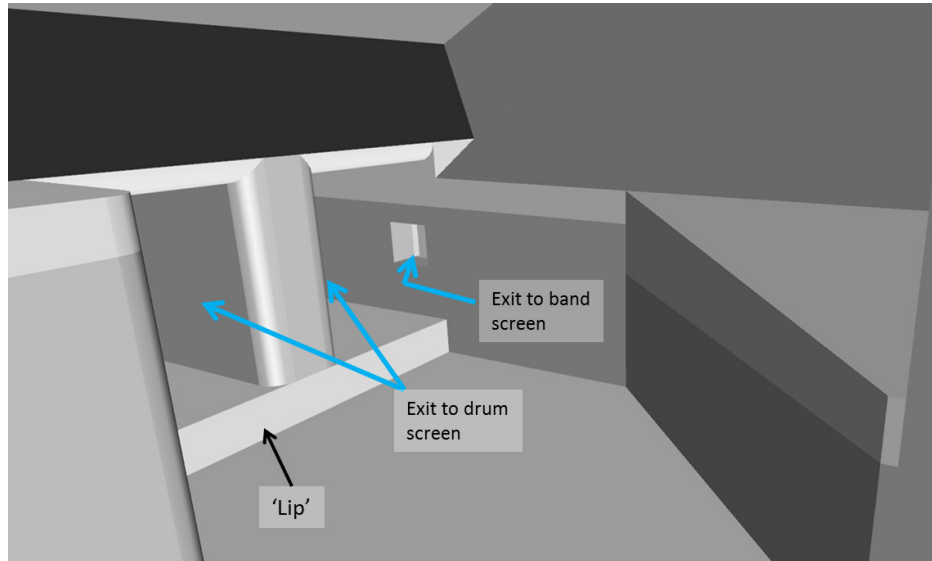

Figure 43: detail of exit from forebay showing 1m high step-up ('lip')

13.1.12 Impact Assessment

- 13.1.13 Impact of forebay hydraulics were not made in the Environmental Impact Assessment (EIA) (which were, as discussed previously, made by comparison with other operational Fish Recovery and Return (FRR) systems) so the change of design would not affect the assessment outputs. The assessment, therefore, is one of compliance with general guidance and best practice.
- 13.1.14 The power dissipation for water exiting the intake tunnel into the forebay is 32 W m³. This is compliant with the Environment Agency guidance that power dissipation should not exceed 100 W m³.
- 13.1.15 However, power dissipation does not really provide too much information in terms of potential impacts on health. Shear stress is a better measure.
- 13.1.16 Shear stress occurs in fluids across a velocity gradient. A fish that enters such an area is exposed to shearing forces across its body, which can lead to various forms of trauma, including scale and mucus loss from the body surface, injuries to exposed delicate organs, principally the eyes and gills Ref [21]. Shear stress, like pressure, is a force per unit area, and has the same units, Newtons per square metre (N m⁻²); but whereas a pressure is directed perpendicular to a surface, shear stress acts parallel to the surface.

13.1.17 Since turbulence results in the formation of vortices across which there may be strong velocity gradients, shear stress and turbulence are closely linked. The most important result is the absolute magnitude range of shear stresses shown by the modelling) (See Figures 44, 45 and 46).

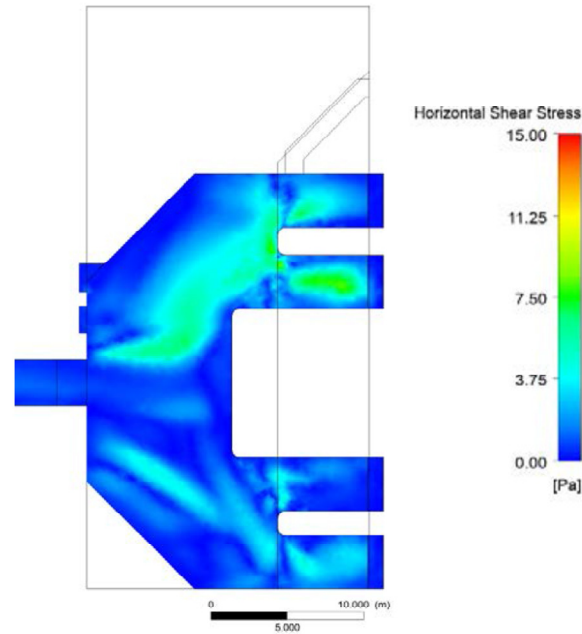

Figure 44: Horizontal shear stress 1 m above the forebay (HPF) floor

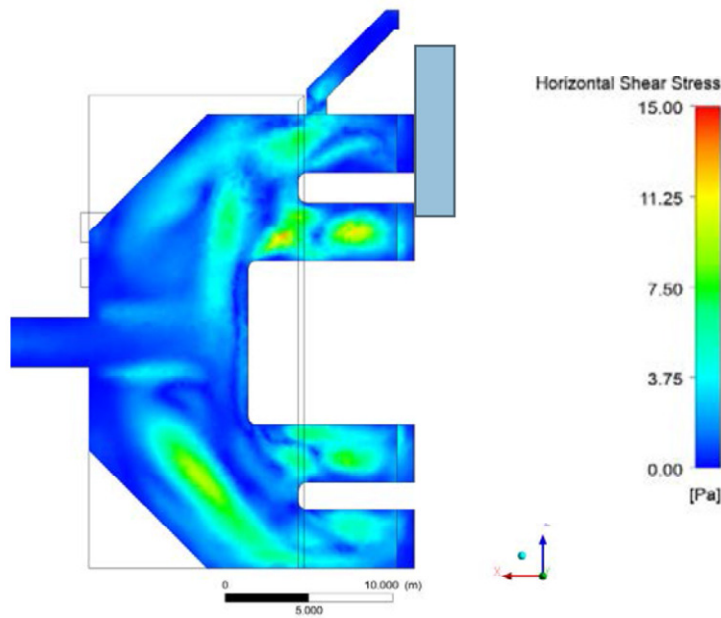

Figure 45: Horizontal shear stress 3 m above the forebay (HPF) floor

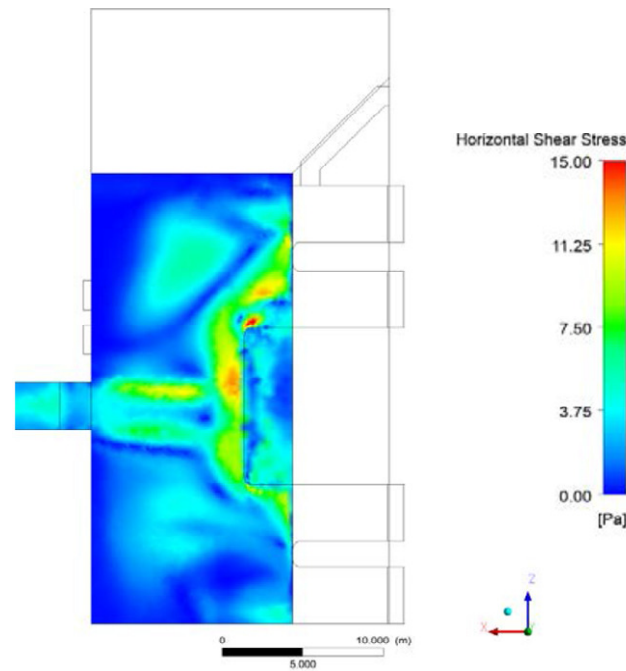

Figure 46: Horizontal shear stress 5 m above the forebay (HPF) floor

- 13.1.18 Each plot has a maximum value of 15 Pa. As 1 Pa (Pascal) = 1 Newton per square metre or 1 N m^{-2} . Thus, a range of values no exceeding 15 N m^{-2} is predicted by the modelling to occur, with actual values closer to 3 or 4 for the majority of the flow and rarely exceeding 12 N m^{-2}
- 13.1.19 Even if one takes the maximum plotted value of 15 N m^{-2} , this can be compared with threshold values for fish injury derived from laboratory studies. In the United States, defined a threshold shear stress value for injury of 1600 N m^{-2} for salmonid fish (see Ref [21]).
- 13.1.20 Of greater relevance to fish species at Hinkley Point is the laboratory work carried out by Turnpenny et al. (1992) (see Ref [21]) which reported injuries recorded at various levels of shear stress generated within a laboratory flume suggesting that the 1600 N m^{-2} criterion is probably applicable more widely. Only levels above $1,600 \text{ N m}^{-2}$ were injuries or mortalities recorded (see Ref [21]).
- 13.1.21 The one exception was juvenile herring, which are particularly fragile and did incur injuries at below 1600 m^{-2} . However, at Hinkley Point C herring are expected not to survive impingement on the fine filtration (CFI) screens and so are not relevant ion this assessment.
- 13.1.22 If one compares the $1,600 \text{ N m}^{-2}$ injury threshold criterion described above with the maximum values in the order of 15 N m^{-2} , it is clear that shear stress values associated with the Hinkley Point C forebay (HPF) design are two orders of magnitude below this value. The underlying reason for this is that shear is caused by differences in velocity

within a localised region of water and the numerical modelling shows that velocities within the Hinkley Point C forebay (HPF) are low.

- 13.1.23 Table 17 provides details of previously reported shear stress injury thresholds for selected fish species relevant to Hinkley Point C (see Ref [21]).
- 13.1.24 The forebay (HPF) has been assessed for flow hydraulics, in particular to provide information on power dissipation, shear stress and fish transit / residence times.
- 13.1.25 Modelled flow scenarios, chosen to represent a good range of tidal states, assessed are presented in Table 18. These were first assessed by HR Wallingford from a hydraulics perspective (using Computerised Flow Dynamics; CFD) and then by Turnpenny Horsfield Associates (THA Ltd) for potential impacts on fish.

Table 17: Shear stress injury thresholds for selected fish species (Ref [21])

Fish Species	Shear Stress Level Nm ⁻²			
	206	774	1920	3410
Salmonids: Atlantic salmon, age 2-gp smolts	No detectable effect	No detectable effect	Slight mucous and scale loss. 28% of fish with eye injury. 4% mortality after 7 d	Slight mucous and scale loss. 32% of fish with eye injury. 8% mortality after 7 d
Salmonids: Brown trout, age 1-2 gp	No detectable effect	No detectable effect	Slight mucous and scale loss. 10% of fish with eye injury. 20% mortality after 7 d	Slight mucous and scale loss. 10% of fish with eye injury. 10% mortality after 7 d
Clupeids: Herring, age 0-group	Light mucous and scale loss. 100% mortality within 1 h	>20% mucous and scale loss per fish. Eye haemorrhage in 60%. 100% mortality within 1 h	Average 58% mucous and scale loss per fish. 60% eye injury. 40% with torn jaws/operculum. 100% mortality within 1 h	Average 90% mucous and scale loss per fish. 40-60% eye injury. 20% with torn jaws/operculum. 100% mortality within 1 h
Clupeids: Twaite shad	Not tested	Not tested	Not tested	Average 90% mucous and scale loss per fish. 40% eye injury. 20% with torn jaws / operculum. 100% mortality within 1 h
Flatfish: Sole	Not tested	No detectable effect	Heavy loss of mucous. 65% mortality within 7 d	Heavy loss of mucous. 75% mortality within 7 d
European eel	No detectable effect	No detectable effect	Some mucous loss. 7-d survival not affected	Some mucous loss. 7-d survival not affected
Percids: Bass	Not tested	Not tested	Average 9% mucous and scale loss per fish. 13% with gill injury. 7% bleeding into body cavity. No survival data	Average 10% mucous and scale loss per fish. 8% with gill injury. No survival data
Gadoids: Whiting Cod	Not tested	Not tested	Average 5% mucous and scale loss per fish. 20% with eye injury. 20% with torn jaws / operculum. 100% mortality within 1 h	Average 5% mucous and scale loss per fish. 28% with eye injury.

Table 18: Flow scenarios modelled by CFD and subsequently assessed by for “fish friendliness”.
 LAT = lowest astronomical tide; MSL = mean sea level; PHE = Extreme High Water Level; HPF = forebay, SEC = Essential Service Water; SEN =Auxiliary Cooling Water System; CRF = Circulating Water system main cooling water flow.

Case	Sea Level (mOD)	Intake Head Losses (m)	Water level inside HPF (m)	Total flow rate per unit (m ³ /s)	Train 1 & Train 4 Flow rate per train (m3/s)	Train 2 & Train 3 Flow rate per train (m3/s)	Flow rate in HPL pipes (m3/s)
1	LAT = - 6.10	3.7	-9.80	58.0	1.5 (SEN)	27.5 (CRF+SEC)	0
2	MSL = + 0.30	2.7	-2.40	65.6	1.6 (SEN)	31.2 (CRF+SEC)	0
3	MSL = + 0.30	2.7	-2.40	60.6	1.6 (SEN)	31.2 (CRF+SEC)	+5
4	MSL = + 0.30	2.7	-2.40	65.6	2.8 (SEC + SEN)	30 (CRF)	0
5	MSL = + 0.30	4.8	-4.50	65.6	1.6 (SEN)	31.2 (CRF+SEC)	0
6	PHE = + 8.14	2.9	+5.24	69.2	2.1 (SEN)	32.5 (CRF+SEC)	0

Source: EDF memo, revised on 26/06/2014

- 13.1.26 The modelled residence times are shown in Table 19 and Figure 47. Mean modelled times range from 48 seconds at Lowest Astronomical Tide (LAT) to 288 seconds (just under 5 minutes) at extreme high water level (PHE). Minima and maxima range from approximately 15 s to 1500 – 4000 s (excluding PHE), respectively. These modelled outputs assume that the fish behave as inert particles, i.e. they do not swim against, or with, the flow; nor do they linger or actively take residence in the forebay (HPF).
- 13.1.27 Residence times of 48 s to 5 minutes are considered acceptable, given the need for fish to be presented on the screens as quickly as possible to allow recovery and onward return to sea (Ref [21]).

Table 19: Modelled residence times for fish in the forebay (HPF) (assuming the fish act as passive particles).

Case	T _{min} (s)	T ₅₀ (s)	T ₇₅ (s)	T ₉₀ (s)	T ₉₅ (s)	T _{max} (s)	T _{mean} (s)
1	15	21	25	82	226	1312	48
2	15	64	294	546	780	2461	205
3	17	75	248	463	658	3887	188
4	14	22	165	535	813	2683	155
5	15	33	214	419	554	1442	144
6	14	20	240	900	1479	7789	288

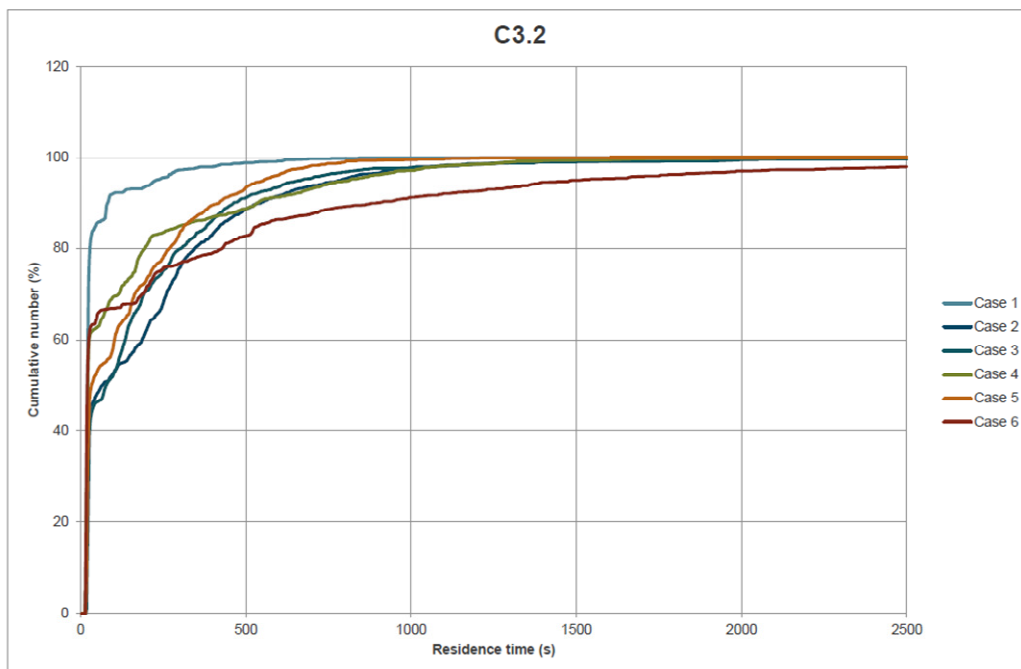

Figure 47: Cumulative distribution of modelled residence times in the forebay (HPF)

13.1.28 However, as described in at Section 13.1.25, the modelled outputs assume that fish exhibit no active swimming behaviour at all and simply go with the flow. This is not realistic for an actively swimming fish.

13.1.29 A detailed analysis of the dynamics of fish clearance from a power station forebay and screenwell complex was undertaken by Turnpenny and Utting (1980) (see Ref [21]) who studied the impingement patterns of sprat at Dungeness ‘A’ power station. The

findings indicated that a school of sprat entering the chamber could take 4 - 5 hours to clear, whereas the mean flushing time comparable with the HRW results presented here was of the order of a few minutes only (and so comparable to the results presented here for Hinkley Point C).

- 13.1.30 The same study showed that when a school of sprats entered, the smaller individuals (averaging about 70 mm in length) were removed first, the larger individuals (averaging up to 95 mm) remaining longest. The most likely explanation of these findings is that the fish actively resisted impingement and that the larger, better swimming fish were able to resist for longer.
- 13.1.31 Thus, the results shown by the particle tracking cannot be considered representative of fish residence times, but shorter particle residence times (like those modelled here for Hinkley Point C).
- 13.1.32 It should also be remembered that the small, rectangular design of the forebay was deliberate such that it reduced sedimentation and thus eradicated areas of slower flow. This is significant because it demonstrates that there are fewer areas of quiet water where fish extend their residence.
- 13.1.33 The modelled streamlines through the forebay (HPF) support the residence times reported in Table 19 and demonstrate that most of the flow passes directly through the forebay (HPF) and into the cooling water pump house (HP) with some, limited circulation in the upper sections of the forebay (HPF) (Figures 48 and 49).
- 13.1.34 In respect of the step-up at the exit of the forebay into the screen wells, during the initial operational phase fish might tend to accumulate in the area below the step. However, sedimentation will occur throughout operation, particularly in this area where there is no through flow, and thus the volume available will decrease. Fish are expected to continue to move through into the screen well due to density dependent responses from proximity to other fish in this area if they do accumulate.

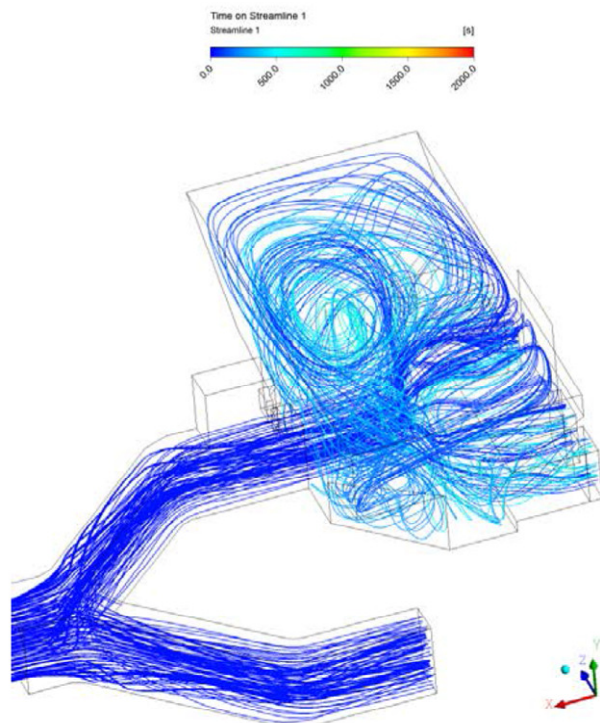

Figure 48: Modelled streamlines through the Hinkley Point C forebay (HPF) (see Ref [20] [21])

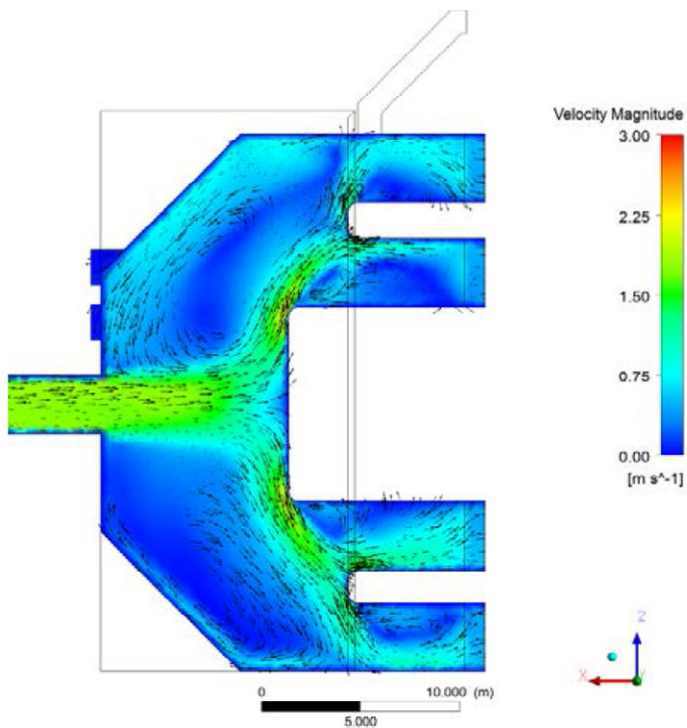

Figure 49: Modelled streamlines through the Hinkley Point C forebay (HPF) (see Ref [20] [21])

- 13.1.35 There is the potential to make a study of fish residence times through the forebay by releasing tagged fish and then recovering them further through the Fish Recovery and Return system. The tags can record a number of parameters, including motion and direction and time of movements.
- 13.1.36 There may also be the opportunity to use acoustic cameras to monitor fish behaviour (including any potential accumulation) in the forebay – this will be considered in the monitoring plan to be prepared for DCO requirement CW2; Marine Licence Condition 5.2.35
- 13.1.37 A monitoring plan to help optimise both the Acoustic Fish Deterrent (AFD) and the Fish Recovery and Return (FRR) systems is required for Development Consent Order (DCO) Requirement CW2. Monitoring of fish transit through the forebay will be considered for that monitoring plan (although optimisation or modification of the forebay itself will not be possible).
- 13.1.38 Where feasible, any ‘sharp’ corners or promontories extending into the forebay will have their edges rounded or smoothed to minimise their potential to cause abrasive or impact damage to fish. Rounding of corners, where possible, will also benefit hydraulic performance to some extent.
- 13.1.39 Conclusion
- 13.1.40 Power dissipation in the forebay (32 W m^{-3}) is compliant with the Environment Agency (Ref [2] [3]) 100 W m^{-3} maximum criterion. However, this has little meaning in terms of biological effects on fish.
- 13.1.41 Shear stress is a meaningful measure of the potential to cause harm to fish, but maximum shear stress predicted for the Hinkley Point C forebay (HPF) is 2 orders of magnitude lower than those reported to cause damage.
- 13.1.42 Residence times for fish in the Hinkley Pint C forebay have been modelled, but constrained by the assumption that fish are behaving as inert particles, which is not realistic. In reality, fish swimming behaviour will affect residence times, but the hydraulics of the forebay have been designed to ensure that sedimentation does not occur which means that there should not be areas where fish chose to rest.
- 13.1.43 Forebay hydraulic performance was not considered in the Development Consent Order ecological assessments and so the specific hydraulic performance of the Hinkley Point C forebay does not alter the assessment findings. However, as outlined above, the forebay (HPF) hydraulics are comparatively fish friendly.

14 COOLING WATER PUMP HOUSE (HP)

14.1 Coarse Filtration (SEF)

14.1.1 Compliance with Environment Agency criteria

14.1.2 The use of raked screens is not recommended from a fish protection perspective (Ref [3]). No specific guidance or criteria are specified, but consideration should be taken of how the system handles large fish.

14.1.3 Given their role is to remove large pieces of debris in advance of the fine filtration system (the band and drum screens) coarse filtration racks are typically spaced wide enough to allow many fish through. Large fish, however, will be impinged so, where coarse racks are fitted, a key consideration is how they handle fish are fitted.

14.1.4 On this topic, the Environment Agency guidance is not prescriptive but states:

“Regulators should be satisfied that the design and performance of any forebay raking system is compatible with FRR requirements”.

As discussed in previous sections, this has been acknowledged in the sense that fish must be able to survive this element if they are to be returned to sea.

14.1.5 Justification

14.1.6 The coarse filtration system (SEF) provides removes large material from the cooling water such that the fine filtration (CFI) system deals only with smaller debris and fish. In that sense it provides a protective role.

14.1.7 The bar spacing is 50 mm.

14.1.8 The possibility of increasing the bar spacing to 75 mm (as found at Hinkley Point B) has been assessed, but been found not to be possible.

(i) EDF practice in respect of the sizing filtration at the cooling water pump house (HP) states that the bar spacing of trash racks should between 40 mm and 60mm, with operating experience (OPEX) showing that a 50 mm spacing achieves an optimal balance between protecting the filtration equipment in the cooling water pump house (HP) and the prevention of frequent clogging of the trash rack.

(ii) In order to avoid reactor shut down due to ‘mass-clogging’ events, the drum screens are designed to be able to clear clogging of $115 \text{ m}^2 \text{ min}^{-1}$ for 10 minute duration (this criterion is derived from EDF operating experience). With the coarse filtration (SEF) rack spacing at 50 mm this criterion is met, but has no margin. Increasing the bar spacing to 75 mm would increase the amount of debris passing through to the drum screens beyond their design capacity.

(iii) An increase in the spacing of coarse filtration (SEF) bar spacing in front of the band screens to 75mm would require the size of the screen buckets to be increased to be able to accommodate extra debris as well as larger fish. An increase in the bucket size would result in a corresponding increase in weight

loading due to the extra water retained in the bucket. Such an increase would have significant impact on the civil loadings and APC requirements.

- (iv) Finally, the supplier (Ovivo) has no operating experience with a coarse filtration (SEF) rack spacing >50 mm. It should be noted that Ovivo are the market leaders and bring a great deal of experience to the HPC project for combining critical safety and operational filtration systems with fish protection measures.

14.1.9 For the reasons outlined at 14.1.8, and given the fact that the material recovered from the coarse filtration (SEF) racks will be transferred to the filtering debris recovery pit (HCB) for onward transfer back to sea, the bar spacing must be 50 mm.

14.1.10 Impact Assessment

14.1.11 Compared with the Hinkley Point B impingement data, having a 50 mm bar spacing for the coast filtration (SEF) racks would alter the impinging figures for sole, cod, plaice, thornback ray, sea lamprey (Ref [22]).

14.1.12 Although the smaller bar spacing will prevent more of the larger (i.e. adult) fish passing through to the drum and band screens (where fish recovery mechanisms are more ‘fish friendly’ than the debris (trash) racks) the impacts on the overall estuary population (expressed as standing stock) is not considered significant (see Table 20; Ref [22]). For example, the impingement predictions for thornback ray with a rack spacing of 75 mm was that Hinkley Point C would affect 0.24 to 0.34% of the local estuary population (standing stock biomass, SSB), compared with 0.64% for 50 mm screen spacing.

Table 20: Impingement predictions for Hinkley Point C with 50 mm bar spacing at debris (trash) racks (Ref [22]).

Species	Number	EAV	Entrapment risk AFD	FRR mortality	EAV number (AFD+FRR)	EAV wt (t)	local fishery (t)	local SSB (t or number in red)	% of local fishery	% local SSB
Sprat	3,566,391	1,604,876	12%	100%	192,585	1.50	0.19	NA	790%	-
Whiting	2,218,158	303,888	45%	50%	68,375	12.17	34	1613	36%	0.755%
Sole	635,856	48,325	84%	26.1%	10,574	2.43	263	3240	0.92%	0.075%
Cod	391,463	701	45%	67.7%	213	0.94	65	975	1.43%	0.096%
Herring	95,494	47,250	5%	100%	2,363	0.30	119	NA	0.25%	-
Plaice	5,678	738	84%	63.7%	395	0.19	84	952	0.23%	0.020%
Thornback ray	3,507	687	100%	54.0%	371	1.01	168	NA	0.60%	-
Blue whiting	1,230	169	45%	50%	38	0.00	37,900	5,360,000	0.00%	0.000%
Eel	1,376	1,376	100%	20%	275	0.08	-	133	-	0.063%
Twaite shad	2,401	66	12%	100%	8	-	-	184,000	-	0.004%
Allis shad	72	19	12%	100%	2	-	-	700,000	-	0.000%
Sea lamprey	218	218	100%	40.7%	89	-	-	15,269	-	0.582%
River lamprey	87	87	100%	20%	17	-	-	116,109	-	0.015%
Salmon	-	-	100%	50%	-	-	-	NA	-	-
Sea trout	-	-	100%	50%	-	-	-	NA	-	-
Crangon crangon	20,185,926	20,185,926	100%	20%	4,037,185	6.02	-	NA	-	-

14.1.13 The impingement predictions provide in Table 20 are based upon scaled up mean impingement numbers obtained at Hinkley Point B (ref. [17], Appendix A). In addition, to providing estimates of the mean for each species, ref. [17] also provided estimates of standard deviation which were typically 20% - 30% of the mean with greater values for rarer species of typically 50%-60%. The data shown in Table 21 have been recalculated to show the range of impingement predictions as upper and lower values calculated as

the mean ± 2 standard deviations. EAV calculations include data of variable uncertainty and so this has not been considered.

Table 21: Impingement range predictions including the impact of band screen seawater abstraction and assuming band screens with their own FRR systems. (Calculated as mean ± 2 std. deviations) (Ref [22])

Species	Mitigated mean EAV wt. (number in red)	Std dev. Wt. (t) or number in red	Lower EAV wt. estimate (t or number)	upper EAV wt. estimate (t or number)	local fishery (t)	local SSB (t or number - in red)	Lower estimate % of local fishery	Lower estimate % local SSB	Upper estimate % of local fishery	Upper estimate % local SSB
Sprat	1.50	0.45	0.61	2.39	0.19	-	321%	-	1258%	-
Whiting	12.2	1.4	9.3	15.1	33.5	1,613	28%	0.58%	45%	0.93%
Sole	2.43	0.54	1.34	3.51	263	3,240	0.51%	0.04%	1.33%	0.11%
Cod	0.94	0.31	0.31	1.56	65	975	0.48%	0.03%	2.39%	0.16%
Herring	0.30	0.08	0.14	0.45	119	-	0.12%	-	0.38%	-
Plaice	0.19	0.05	0.10	0.28	84	952	0.12%	0.01%	0.34%	0.03%
Thornback ray	1.01	0.32	0.36	1.65	168	-	0.21%	-	0.98%	-
Blue whiting	0.00	0.00	0.00	0.01	37,900	5,360,000	0.00%	0.00%	0.00%	0.00%
Eel	0.08	0.02	0.05	0.12	-	133	-	0.04%	-	0.09%
Twaite shad	8	2.4	3	13	-	184,000	-	0.00%	-	0.01%
Allis shad	2	1.3	0	5	-	700,000	-	0.00%	-	0.00%
Sea lamprey	89	43.8	1	177	-	15,269	-	0.01%	-	1.16%
River lamprey	17	9.7	0	37	-	116,109	-	0.00%	-	0.03%
Crangon crangon	6.0	0.9	4.2	7.9	-	-	-	-	-	-

- 14.1.14 However, it should be remembered that although Hinkley Point C has a smaller bar spacing on for its coarse filtration (SEF) racks, it does have a raking system that will recover (some) impinged fish and return them to sea. At Hinkley Point B there is no raking system (the racks are removed every 3 months and cleaned manually). So the impacts outlined above from having a smaller bar spacing could be considered conservative when compared directly to Hinkley Point B figures.
- 14.1.15 It is inevitable that very large fish, that cannot be recovered by the buckets of the debris (trash) rakes will remain in the forebay and be lost from the estuarine fishery; however this is also true of very large fish entrapped into the Hinkley Point B forebay that do not pass through the rack. It should be remembered that no statistical difference was found between HPB fish capture data and surveys at the HPC intake locations (ref. [17]).
- 14.1.16 There are no data available with which to assess fate or impacts of very large fish that do not get recovered onto the coarse filtration (SEF) racks. However, there is the possibility to monitor this at Hinkley Point C using remote sensing equipment (such as acoustic cameras) and/or tagging experiments. This will be considered in monitoring plans (i.e. for DCO requirement CW2; Marine Licence Condition 5.2.35).
- 14.1.17 Conversely, it is possible for exhausted, small fish to present lengthways on to the coarse filtration (SEF) rack and become impinged. These fish will either re-orientate themselves or burst after resting to allow them to pass through the rack; if they are unable to do so they will be recovered by the rake on the next cycle. Exhausted fish presenting sideways on to the coarse filtration (SEF) rack HPB would not be recorded

in the impingement data as there is no rake at HPB, so the HPC design provides additional mitigation for this scenario over the HPB design.

- 14.1.18 Apart from the bar spacing, there is no other metric on which to make an assessment.
- 14.1.19 Routine raking frequency is presently assumed to be 4 times per day (1 cycle every 6h), with additional cycles triggered by head-loss indicative of a mass clogging event. Raking frequency will be addressed during commissioning and will be considered. Consideration of increased routine raking will be made in the monitoring plan required for DCO requirement CW2; Marine Licence Condition 5.2.35.
- 14.1.20 Equally, the degree of fish-friendliness of the debris (trash) rake bucket will not be available until the detailed design phase. However, the supplier will be contractually constrained to ensure that the buckets (skips) are (i) as fish friendly as possible, within other constraints such as civil loadings, operability etc. (for example, the bucket 'teeth' will be angled in such a way to manipulate fish as gently as possible), and (ii) caters for the size and shape of fish expected of be impinged.
- 14.1.21 The transit from the skip to the hopper will also be optimised for fish-friendliness during the detailed design phase.

14.2 Fine Filtration (CFI) (Drum and Band Screens)

14.2.1 Compliance with Environment Agency criteria

- 14.2.2 For fine filtration systems the Environment Agency (Ref [2] [3]) provides the following guidance / criteria:
- (i) screens should rotate continuously so that fish are not impinged against the screen for long periods before removal;
 - (ii) screens should rotate at constant speed of at least 1.5m min⁻¹ to minimise fish handling time;
 - (iii) screen meshes should be smooth and fish-friendly, constructed from woven stainless steel or plastic mesh;
 - (iv) screen mesh size should be 6 mm or less;
 - (v) backwash sprays for flushing fish from the screens should be low pressure (≤ 1 bar) (high pressure backwash sprays may be used for clearing debris after the fish have been removed safely);
 - (vi) biocides should be applied only downstream of the screens unless it can be shown that the toxic risk is negligible.
 - (vii) geometry of the collection hoppers should ensure that fish washed off the screens cannot fall back into the screen well; this can be particularly important for sinuous species such as eels and lampreys.
 - (viii) Although not a specified in Environment Agency criterion, the Environment Agency has, during consultation of the HPC design, stated that flow velocities onto the fine filtration (CFI) screens should be sufficiently high to ensure that fish are impinged effectively.

- 14.2.3 The Hinkley Point C fine filtration (CFI) system is considered largely conventional and so by design it meets many of the recommendations and criteria of the Environment Agency listed above:
- (i) the drum screens and the band screens will rotate continuously - this is considered conventional operation for the drum screens, but unusual for the band screens (see Justification; section 14.2.4);
 - (ii) under normal operations the drum screen will rotate at constant speed of at least 2.5 m min^{-1} ;
 - (iii) under normal conditions the band screen will rotate at only 0.5 m s^{-1} (see Justification; section 14.2.9);
 - (iv) the screens will continue to rotate for a further half a rotation after the cooling water pumps have stopped to ensure that fish are not left stranded in buckets (amount of rotation will be considered further during monitoring and adjusted accordingly if feasible);
 - (v) screen meshes will be smooth and made from woven stainless steel;
 - (vi) drum screens will have fish collection buckets located on every spoke cross member; there will be 56 pairs of buckets on each drum screen
 - (vii) screen mesh size will 5 mm (square) for both the drum screen and the band screen mesh; 5 mm mesh size is not compliant with the Environment Agency's guidance for young eels (Ref [4]) but the 5 mm mesh size cannot be reduced without encroaching on nuclear safety calculations;
 - (viii) backwash sprays for flushing fish from the screens will be low pressure (= 1 bar);
 - (ix) high pressure backwash sprays will be used for clearing debris after the fish have been removed safely (3.5 and 6.5 bar for both drum and band screens);
 - (x) sprays will be maintained to ensure that blockages do not lead to increased pressures at outlet;
 - (xi) spray direction will be optimised during the commissioning phase to ensure they flush the buckets correctly;
 - (xii) under the present environmental conditions at Hinkley Point, and the biological fouling risk assessment thereof, biocides will not be applied at all in the cooling water system²⁰
 - (xiii) the collection hoppers, and the geometry from fish bucket to release, are designed to ensure that fish fall into the hopper and not back into the well;

²⁰ For the operational Water Discharge Activity (WDA) permit, issued by the Environment Agency there is a pre-operational condition (PO7) that requires NNB GenCo (HPC) Ltd to provide strategy for assessing the risk of biofouling and potential subsequent need for application of chlorination. If environmental conditions change in the future it may be necessary to start dosing with chlorine to control biofouling, but any such application will need to be assessed and applied according to the (approved) strategy.

(xiv) the detailed design of the drum screen fish buckets will be finalised in the detailed design strategy, but will be informed by operational experience at other power stations, such as Pembroke CCGT.

(xv) Average flow velocities on to the band screens range from 0.05 m s^{-1} to 0.16 m s^{-1} depending on tidal level (Section 6.2.8). Average flow velocities on to the drum screens is 0.5 m s^{-1} (Section 6.3.9).

14.2.4 Justification

14.2.5 As can be seen from Sections 14.2.2 and 14.2.3, the only specified criterion that is not met by the Hinkley Point C fine filtration (CFI) system is the rotation speed of the band screens, due to impact on the wear of the chain at high rotation and the impact on the reliability of this equipment which have a significant role in Nuclear Safety (Safety Classification 1).

14.2.6 As described in Section 6.2, the band screens filter the water that serves the service and safety cooling water systems (the auxiliary cooling water, essential service water and ultimate cooling water systems; SEN, SEC and SRU, respectively). Because of this, the band screens are nuclear safety classified. They are seismically qualified and qualified to withstand air plane crash (APC qualified).

14.2.7 Normally, the band screens do not operate continuously on EPR stations – they typically rotate once every 6 hours (on a timer) or on demand when triggered by an increase in headloss (indicative of a large clogging event).

14.2.8 Intermittent rotation, however, is not compliant with Environment Agency recommendations, although it is recognised that wear of the band screens motor and other mechanical parts (e.g. pins and bushes) may constrain continuous operation.

14.2.9 For the Hinkley Point C band screens, mechanical wear is a constraint on continuous operation at the recommended rotation speed of 1.5 m s^{-1} (minimum), but assessment has shown that continuous rotation at 0.5 m s^{-1} can be achieved with significant impacts on service and maintenance intervals. Apart from the associated increase in operator burden, shorter service intervals impacts on the availability of these safety classified filtration systems, therefore, encroaches on the cumulative safety case margin (Ref [7]).

14.2.10 Continuous operation at 1.5 m s^{-1} necessitates a service interval of 2.5 years, continuous operation at 1.0 m s^{-1} necessitates a service interval of 3.25 years, whereas continuous operation at 0.5 m s^{-1} necessitates a service interval of 4.75 years (Ref [7]).

14.2.11 A service interval of nearly 5 years is acceptable, but an interval of just over 3 is not due to availability and nuclear safety requirements (Ref [7]).

14.2.12 Some chain manufacturers advocate the use of synthetic materials (plastic or composite materials) instead of metal for parts subject to wear, in order to increase the life of the components. However, such materials are not isotropic (i.e. the values of a property depend on the direction), and lead to using unusual methodologies and assumptions for sizing calculations. Critically, synthetic screens cannot be APC classified which is a safety requirement for the band screens (see 14.2.6).

- 14.2.13 The EDF group of companies has no operational experience of using screen components manufactured from synthetic materials and cannot risk their use on nuclear safety classified plant.
- 14.2.14 Although not a specific criterion, velocities across the fine filtration (CFI) screens also warrants further discussion. Velocities across the drum screens, at 0.5 m s^{-1} are high and sufficient to ensure that fish are effectively impinged on the drum screens. However, velocities across the band screens are lower (0.05 m s^{-1} at HAT) and so fish might not be impinged efficiently onto the band screens.
- 14.2.15 The approach velocities reported in Section 6.2.8 are average values based on an homogenous flow across all of the filtration surface and so underestimate the efficiency to which fish will be impinged. In reality, the bulk of the flow will concentrate around the lower section of the band screen on both sides of the suction eyes. Under normal operational conditions (with 1 Essential Services Water System (SEC) pump and 1 Auxiliary Cooling Water System (SEN) pump operating) the flow velocity at the suction eye is approximately 1 m s^{-1} . So, the flow velocity on to the band screen mesh will be 0.5 m s^{-1} local to the suction eye (2 sides of the screen so flow is halved) and much lower on to the remainder the band screen mesh. It is worth remembering that the total surface area of the band screen mesh is large so that it can withstand clogging and remain sufficiently submerged at extreme low water.
- 14.2.16 There is no means to increase flow velocity onto the band screens as the hydraulics of the forebay and cooling water pump house (in particular for the band screens, which perform a nuclear safety function) are constrained by complex factors.
- 14.2.17 Impact Assessment
- 14.2.18 As described in Section 6.2, the band screens at Hinkley Point C need to be 25 m high to encompass all tidal scenarios for the Bristol Channel (which has the 3rd largest tidal range in the world). Operating at its 'creep speed' of 0.5 m s^{-1} , therefore, at very low tidal levels (such as low water on Spring tides) fish recovered in the band screens could take upwards of 40 minutes to travel from their initial removal from the water in the bucket to the point where they are discharged into the fish collection gutters and onwards transmittal to the filtering debris recovery pit (HCB). It is therefore necessary to assess the impact of this comparatively long transit time on the relevant fish species.
- 14.2.19 As described several times already, pelagic fish such as herring and sprat are not expected to survive impact on the screens themselves and so 100% mortality is expected. However, these species show very high deflection rates from AFD systems and so should not be entrapped in the Hinkley Point C cooling water system to any significant degree. Therefore, the assessment of the long transit time for fish in a band screen bucket at Hinkley Point C need only consider those species that are predicted to show at least some survival through the Fish Recovery and Return (FRR) system. At Hinkley Point C these include gadoids (cod and whiting), flatfish (sole and plaice) and eels.
- 14.2.20 There are few available data on the impacts of transit time in fish buckets on fish survival and, in any case, they would likely not be comparable due to differences in

bucket design. A. Turnpenny assessed the impacts of longer bucket transit times on fish survival at Sizewell B (Ref [23]), to determine whether reducing rotation speed of the drum screens (again, to reduce maintenance burden) would have an impact on Fish Recovery and Return efficiency. Although the reduced rotation speed led to transit times of only 12 minutes or so (compared with a maximum of 46 minutes at Hinkley Point C), survival of flatfish was unaffected by the longer transit time spent in the buckets. Flatfish in the longer transit time did show a slight reduction in survival, but this was not statistically significant. However, the gadoids (cod and whiting) did show a significant reduction in survival, from 55% to 29%, in the longer transit times.

- 14.2.21 Anecdotal evidence from impingement monitoring at Hinkley Point B and Sizewell B, and expert opinion from CEFAS fish specialists, provides a similar assessment.
- 14.2.22 In fish friendly buckets (which retain water and prevent fish from falling out), flatfish, gobies and eels are expected to survive for up to 1 hour. Cod and whiting do not show such high survival in Fish Recovery and Return systems anyway and would not be expected to survive such a period (although 10-15% might be expected to survive periods up to 30 minutes, depending on fish density in the bucket etc.).
- 14.2.23 Even if one assumes 100% mortality for cod and whiting on the Hinkley Point C band screen fish recovery buckets, the impacts on their respective populations are not considered significant. For whiting, the number of fish that would not survive impingement would rise from representing 0.72% of the estuary's standing stock biomass (SSB) to 0.78% of the SSB. For cod, the number would increase from 3.24% to 3.5%.
- 14.2.24 Other key species impinged at Hinkley Point C, considering only those species that would be expected to survive impingement anyway, would be expected to show comparable survival on the band screens as they would on the drum screens.
- 14.2.25 In conclusion, on the assumption that the band screen fish recovery buckets will be optimised for fish friendliness, in particular that they will retain water and be designed such that fish cannot fall out, survivability of the relevant species is expected to be good. Even if survivability were to be less than predicted above, the numbers of fish impinged on the band screens would not lead to significant impacts on estuarine fish populations.
- 14.2.26 Aeration of the water in the band screen buckets, suggested as a potential means of improving conditions in the buckets during long transit, is not feasible. Providing air-lines to each individual bucket, given that the screen is continuously moving, cannot be done in a robust manner that will work reliably.
- 14.2.27 The band screens are enclosed, so the fish in the buckets will be well-shaded shielded from external temperature fluctuations and shielded from visual disturbance. The combination of the sprays operating at the top of the band screens, and the fact that the structure is enclosed, will maintain high humidity.
- 14.2.28 The fish protection measures will be monitored during commissioning, and into operation, to enable the system to be optimised wherever possible (within any necessary operational or safety constraints). If monitoring suggests that it may be beneficial to increase the rotation speed of the band screens at certain, discrete times

for example when large inundation of fish occurs, or transit times are particularly long, it may be feasible to do so.

- 14.2.29 As described in section 6.2.10, the band screens can operate at two, set speeds: 2.5 and 10 m s⁻¹ in addition to what will be the 'usual' 'creep' speed (0.5 m s⁻¹). To be clear, the motor has 3 set speeds, it is not variable speed, and so any increase in speed would be to 2.5 m s⁻¹. The potential for increasing the rotation speed of the band screens at strategic times (e.g. very low tides) will be examined during the commissioning and long term monitoring (and, therefore, included in the monitoring and adaptive measures plan under DCO Requirement CW2 and Marine Licence Condition 5.2.35).
- 14.2.30 By comparison, the drum screen will rotate at 2.5 m s⁻¹, resulting in a maximum transit time on the buckets for fish collected at Lowest Astronomical Tide (LAT) of 8 minutes. This is considered sufficient for survival of any of the relevant fish species.
- 14.2.31 Historically, the presence of high numbers of crabs in fish buckets has been detrimental to the survival of the fish. Crabs are inherently aggressive and, when enclosed in the confines of the buckets, tend to attack fish causing potentially serious injuries.
- 14.2.32 At Hinkley Point C, due the elevated position of the intake apertures (approximately 1 m above the sea bed), crabs are not expected to be entrapped in any significant numbers. This is in contrast to the Hinkley Point B intake where the intake aperture is at seabed level and therefore prone to take in far great numbers of mobile benthic organisms.
- 14.2.33 Surveys in 2008 - 2010 and 2012 - 2013 found crabs in the vicinity of both the intake of Hinkley Point B and the intake of Hinkley Point C (see Ref [24] [25]), with fewer being found in the deeper waters near the Hinkley Point C intake location. See Table 22.

Table 22: Crab survey results (2008–2010; 2012–2013) (Ref [24] [25])

	Stations near HPC intakes				Stations near HPB intakes				
	HP10	HP5	HP151	HPC	HP70	HP71	HP106	HP107	HPB
June 2008									
<i>Corystes cassivelaunus</i>	-	-	-	-	1	-	-	-	-
<i>Liocarcinus holsatus</i>	-	1	-	-	5	7	-	-	-
August 2008									
<i>Liocarcinus holsatus</i>	-	-	-	-	1	2	-	-	-
November 2008									
None	-	-	-	-	-	-	-	-	-
May 2009									
<i>Liocarcinus holsatus</i> (juv)	17	-	-	-	8	1	2	1	-
June 2010									
<i>Pagurus bernhardus</i>	-	-	2	-	-	--	-	-	-
<i>Liocarcinus holsatus</i>	-	-	1	-	2	2	-	-	-
June 2012									
None	-	-	-	-	-	-	-	-	-
August 2013									
<i>Liocarcinus</i> (juv)	-	-	-	0	-	-	-	-	3
<i>Liocarcinus marmoreus</i>	-	-	-	2	-	-	-	-	3
<i>Carcinus maenas</i>	-	-	-	0	-	-	-	-	1

14.2.34 As described already, the Hinkley Point C impingement predictions were made form scaling up the Hinkley Point B impingement figures. However, impingement at Hinkley Point B is not a good indicator of crab impingement at Hinkley Point C because the intakes are at different heights off the seabed.

- 14.2.35 The aperture for Hinkley Point B is level with the bed, so mobile epifauna ingress is to be expected because the animals can simply crawl into the heads or be drawn horizontally across the seabed. However, the Hinkley Point C intakes will be approximately 1.0 m above the seabed and it is difficult to conceive how crabs could scale this distance vertically.
- 14.2.36 Whilst some crabs of the family Portunidae, including the *Liocarcinus* recorded in the offshore surveys (Ref [24] [25]), have a limited swimming ability, they are not likely to be found any distance off the bed or sufficiently high into the water column to be swept into the Hinkley Point C intakes. For example, the whole water column near to the Hinkley Point B and Hinkley Point C intakes was surveyed in 2012 and again in 2013 and crabs were not recorded in mid-water.
- 14.2.37 Average flow velocities onto the band screens are low and might suggest that fish will not be efficiently impinged on to the screen. However, in reality localised flows around the suction eye are high enough to ensure this (see Section 14.2.15). If fish do not impinge efficiently onto the screen there is the possibility that they could accumulate in the band screen well, however, they would not be expected to move back out into the main forebay due to velocities in the band screen feed channel (2.0 m s^{-1}). For those fish that do not move onto the screen due to the flow velocities local to the suction eye, the expectation is that once numbers of fish had increased density dependence responses would drive fish onto the screens (A. Turnpenny, pers. comm).
- 14.2.38 Potential lower efficiency of rapid impingement at the band screens is not considered to alter the impact assessment due to (a) density dependent responses pushing fish towards the screen, and (b) only a small percentage (up to 9%) of entrapped fish taking this route through the pumphouse.
- 14.2.39 Conclusion
- 14.2.40 The Hinkley Point C drum screens meet Environment Agency criteria (Ref [2] [3]). The detailed design of some aspects (for example, the bucket design) cannot be confirmed until the detailed design stage, but will be fish friendly.
- 14.2.41 The Hinkley Point C band screens meet most of the Environment Agency criteria, apart from the rotation speed.
- 14.2.42 The design has been modified a great deal to improve fish protection, but operational maintenance constraints (with nuclear safety implications) prevent them from operating at the minimum recommended rotation speed of 1.5 m s^{-1} . Instead, a 'creep speed' of 0.5 m s^{-1} will be used.
- 14.2.43 The creep speed of the band screens means relatively long transit times for fish recovered in the buckets on very low tides (up to 46 minutes before discharge to the collection gutters). This long transit time is not considered significant for most of the relevant species predicted to be impinged at Hinkley Point C (flatfish and eels are expected to survive this period, and pelagic such as herring and sprat will not survive impingement on the screen mesh anyway).

14.2.44 Gadoids (cod and whiting) may experience some harm (stress or mortality) during the longer transit times. However, even the worst case assessment, whereby 100% mortality is assumed, shows that the impacts on the fish population would not be significant.

14.3 Collection Gutters

14.3.1 Compliance with Environment Agency criteria

14.3.2 The Environment Agency provides specific criteria in respect of fish collection and transit gutters for Fish Recovery and Return (FRR) systems:

- (i) Bends and drops in the collection gutter network should be minimised;
- (ii) Gutters should be smooth, with any joints properly grouted and finished so there are no snags;
- (iii) Collection gutters should have a minimum diameter of 300 mm
- (iv) The main return gutter should be at least 500 mm in diameter
- (v) Bends for gutters < 400 mm diameter should be swept and have a minimum radius of 3.0 m;
- (vi) Bends for gutters > 400 mm diameter should be swept and have a minimum radius of at least 1.5 times the gutter diameter;
- (vii) The gradient /slope of launders that feed into horizontal bends should be no more than 1:50 (i.e. no steeper than 1:50 (or $\leq 2\%$));
- (viii) Where drops occur, power dissipation should be less than 100 W m^{-3} ;
- (ix) Debris and fish should not be combined.

14.3.3 The Hinkley Point C cooling water pump house gutters (as well as other gutters, such as the Fish Return System (HCF) route to sea gutter; see Sections 6.4, 8.1.4 and 8.1.22) comply with all of these criteria:

- (i) Gutters will be lined with High density Polyethylene (HDPE) which is very smooth (Strickler coefficient = 100); joints will be properly grouted and finished so there are no snags;
- (ii) Coarse filtration (SEF) gutters in the cooling water pump house (HP) are 600 mm; fine filtration (CFI) gutters in the cooling water pump house (HP) are 400 mm;
- (iii) There are no gutters < 400 mm in the cooling water pump house
- (iv) Bends occur where the individual collection gutters join the common gutters; the radii of the bends is 600 mm (i.e. $1.5 \times$ the gutter diameter);
- (v) Slope of the common collection gutter is 0.5% (i.e 1:200); slopes of the individual gutters from the screens to the common gutter are 2.0% (i.e. 1 :50);
- (vi) There is a maximum of 20 individual, vertical drops in the cooling water pump house (HP):

- (a) from each of the rakes in the coarse filtration (SEF) system, where the rake empties its contents into the common collection gutter. The height of the drop ranges from 240 mm for train 1 (band screen channel furthest from the filtering debris recovery pit (HCB)) to 670 mm for train 4 (band screen channel closest to the filtering debris recovery pit (HCB)). The increase in the drop height is due to the gutter sloping towards the HCB building;
 - (b) there is a drop of approximately 500 mm from the each of the band screen buckets into the collection gutter (this distance will be defined during the detailed design stage when the supplier (Ovivo) designs the band screen / gutter interface. However, the drop is not a free-fall drop because the fish will slide across the mesh of the screen for most of this transition;
 - (c) there is a drop of 0.26 – 0.41 m from each of the drum screen buckets into the collection hoppers; but also the fish will slide along the slope of the hopper with additional flushing water provided by dedicated sprays (note, each drum screen has pairs of buckets).
 - (d) there are (potentially, depending on the operational condition) 2 drops at transitions in the gutter network of the cooling water pump house (HP) itself: from the drum screen collection gutters furthest away from the filtering debris recovery pit (HCB) (i.e. the eastern side of the drum screens at Hinkley Point); the drop would range from 0 to 30 mm.
 - (e) power dissipation cannot be calculated with any accuracy, or meaning for fish falling into gutters.
 - (f) there is a drop where the coarse (SEF) and fine (CFI) filtration gutters enter the filtering debris recovery pit (HCB). This drop is minimal, because the gutter invert level is the same as the water level in the filtering debris recovery pit (HCB) basin, so the drop corresponds to the water depth in the gutter.
- 14.3.4 As much as possible, debris and fish are kept in separate gutters. The debris recovered from the coarse (SEF) filtration system is transported to the filtering debris recovery pit (HCB) in a separate gutter to the material and fish from the fine filtration (CFI) system. Large fish impinged on the coarse filtration (SEF) rack will be mixed with the debris recovered from those racks, but most fish will be kept separate (in the fine filtration (CFI) system gutter).
- 14.3.5 Justification
- 14.3.6 The Environment Agency (Ref [2] [3]) does not define maximum height for drops in Fish Recovery and Return (FRR) systems; the recommendation is simply to minimise them.
- 14.3.7 The design of the Hinkley Point C Cooling water pump house (HP) gutters has undergone considerable revision to reduce vertical drops. The drops cannot be reduced further as screen discharge points and gutter elevations are constrained by tidal levels, platform levels, gradients and flushing rates.

- 14.3.8 A full review of the design revision and optimisation is provided in Ref [9], but is summarised below in the following sections.
- 14.3.9 Vertical drops have been reduced by:
- (i) raising of the train 2, 3, 4 gutter starting point invert level from 9.41 m ODN to 9.66 m ODN and the train 1 gutter from 8.97 m ODN to 9.37 m ODN;
 - (ii) reducing the gradient for the train 2, 3, 4 common gutter from 1.0% to 0.5% so that the gutter only descends by 370 mm across the width of the Cooling water pump house (HP) as opposed to 740 mm in the previous design. The reduction in flow velocity associated with the shallower gradient is compensated by the increased smoothness of the gutters by switching from unfinished concrete to High Density Polyethylene (HDPE) or equivalent;
- 14.3.10 The gutters cannot be optimised further to reduce vertical drops due to the following constraints:
- (i) the entire gutter run cannot be raised any higher as the combined elevation of invert level (gutter elevation) plus the water level (in the gutter) at the start of the run (i.e. the highest point) is already at 9.90 m ODN and must remain below 10.14 m ODN; a reasonable margin (in this instance, 240 mm) must be included to prevent the gutters from overflowing and flooding the cooling water pump house (HP);
 - (ii) the gutter gradients cannot be reduced any further as they must ensure the evacuation of all wash water, fish and debris out of the cooling water pump house (HP) into the filtering debris recovery pit (HCB); reducing the gradients further would compromise the efficient flow of material; along the gutter.
- 14.3.11 However, there may be some scope for a further reduction in the vertical drops through lowering the height at which the trash rakes discharge their contents empty into the gutters, which will be optimised during the detailed design stage by the equipment supplier (Ovivo).
- 14.3.12 As stated above, power dissipation cannot be calculated with any accuracy, or meaning for fish falling into gutters.
- 14.3.13 Power dissipation is typically applied to areas where fish may linger or take refuge, such as a pool, as it gives a measure of the turbulence in that area (Ref [2] [3]). Power dissipation itself is calculated using the volume of water in that area (e.g. pool).
- 14.3.14 Power dissipation cannot be readily calculated for fish falling into collection gutters because the volume of the pool cannot be accurately provided, unless the volume of water in the whole gutter is used. This is not considered appropriate. Equally, a more constrained volume (within a given distance of the drop) for the calculation of instantaneous' power dissipation (or turbulence) is not considered appropriate either.
- 14.3.15 In any case, the application of power dissipation, and its potential impacts on fish, does not apply for fish falling into the gutter as fish will not wish or be able to linger or take refuge at these locations as they will be flushed along in the gutter.

- 14.3.16 Separation of fish and all debris is not feasible without significant extra handling processes, and such handling is also considered detrimental to fish well-being (see Impact Assessment).
- 14.3.17 Impact Assessment
- 14.3.18 The gutter network in the Cooling water pump house (HP) is largely compliant with Environment Agency criteria (Ref [2] [3]).
- 14.3.19 Furthermore, in respect of drops there is no means by which to assess impacts.
- 14.3.20 As much as possible, debris and fish are kept in separate gutters.
- 14.3.21 The debris recovered from the coarse (SEF) filtration system is transported to the filtering debris recovery pit (HCB) in a separate gutter to the material fish from the fine filtration (CFI) system. Large fish impinged on the coarse filtration (SEF) rack will be mixed with the debris recovered from those racks, but most fish will be kept separate (in the fine filtration (CFI) system gutter).
- 14.3.22 There will also be some finer debris recovered from the fine filtration (CFI) system as well as fish so, necessarily, fish will be mixed with fine debris in the fine filtration (CFI) system gutters. Debris concentration will be low, so the risk of fish injuries or suffocation by small debris is unlikely (ref [gutters]).
- 14.3.23 For both the coarse (SEF) and fine (CFI) filtration, the water flow in the gutters will be sufficient to flush the material along and prevent fish from being smothered by large quantities of debris.
- 14.3.24 Furthermore, the increased handling required to separate fish from all debris is considered more detrimental to the fish than allowing them to mix with the debris.
- 14.3.25 However, gutters will be routinely checked to ensure that blockages do not occur (this is done as a simple operational need to ensure that the Cooling water pump house does not overflow, but in so-doing will ensure that debris does not accumulate that could injure the fish).
- 14.3.26 The Environmental Impact and Habitats Regulations Assessments (EIA and HRA, respectively) for the Hinkley Point C Development Consent Order (DCO) used generic survival rates for fish travelling through Fish Recovery and Return (FRR) systems. Assessment of the intricacies of the Hinkley Point C gutter system would not affect the overall assessment as these elements would not have been included in those generic rates.
- 14.3.27 The Cooling water pump house (HP) gutter network, therefore, does not affect the impact assessment made for Hinkley Point C.

15 FILTERING DEBRIS RECOVERY BUILDING (HCB)

15.1.1 Compliance with Environment Agency Criteria

15.1.2 The Environment Agency does not provide recommendations for the design of the filtering debris recovery pit (HCB) specifically.

15.1.3 However, general criteria can be applied, together with guidance on particular pieces of equipment (such as raking systems and Archimedes' screws):

- (i) Bends and drops in the system should be minimised;
- (ii) Where drops occur, power dissipation should be less than 100 W m^{-3}
- (iii) Where drops into pools do occur in the system, the depth of the receiving water should be at least 25% of the differential head loss, and at least 900 mm for head differences of $<3.6 \text{ m}$;
- (iv) Raking systems should be as 'fish friendly' as possible and "*Regulators should be satisfied that the design and performance of any [forebay] raking system is compatible with FRR requirements*".
- (v) Archimedes' screws should be of the 'shrouded' type (i.e. enclosed in an integral cylinder where the screw and the cylinder rotate together as a whole) top prevent 'pinching' of fish;
- (vi) The leading edges of an Archimedes' screw (i.e. at the entrance) should be rounded to protect fish from strike injuries.

15.1.4 The design of the Hinkley Point debris recovery (HPB) building is compliant with these criteria, ensuring that the:

- (i) There are, necessarily, drops in the system where the Cooling water pump house gutters enter the debris recovery (HPB) building and discharge their contents into the basin.
- (ii) The power dissipation for these drops varies according to flow rates from the Cooling water pump house (HP). With minimum flow power dissipation will be 16 W m^{-3} , and with maximum flow power dissipation will be 33 W m^{-3} .
- (iii) The Archimedes' screw used to evacuate water from the filtering debris recovery pit (HCB) will have a variable speed motor controlled by feedback from a water depth sensor so that depth of water in the filtering debris recovery pit (HCB) receiving basin is maintained at 900 mm.
- (iv) By definition, the filtering debris recovery pit (HCB) needs a mechanism to remove debris from the water flow, and at Hinkley Point C this will be achieved with a raking system. The design is as 'fish friendly' as possible (see also Justification)
- (v) The Archimedes' screws will be fully shrouded and the leading edges at the entrance will be curved.
- (vi) Precise details of the Archimedes' screw are not yet known and will be determined by the equipment supplier; however, certain criteria are imposed on the design to ensure fish friendliness is optimised:

- (a) the minimum diameter for the Archimedes' screw will be 2.0 m (this is larger than necessary from a blockage mitigation perspective, which requires a minimum of 1.5 m diameter, but has been increased to allow rotation speed to be reduced to improve fish friendliness;
- (b) it will rotate at a maximum speed of 25 revolutions per minute (RPM);
- (c) it will have a maximum tip speed of 2.5 m s^{-1} ;
- (d) it will have no more than 3 flights (blades);
- (vii) There will be one further drop at the top of the Archimedes' screw, as it discharges its contents into the receiving basin. The height of this drop cannot be defined yet as that, too, will depend on the detailed design of the Archimedes' screw (whereby, the height of the drop will be determined by slope of the Archimedes' screw, which will in turn be defined by the diameter and length of the screw). Again, compliance with the 100 W m^3 will be an absolute requirement of that design, with optimisation to reduce the drop height and power dissipation made where feasible.

15.1.5 Justification

- 15.1.6 Two aspects of the Hinkley Point C filtering debris recovery pit (HCB) that require further explanation are the raking system and the Archimedes' screw (in respect of the need to raise the water at all).
- 15.1.7 The raking system is required to remove large debris from the system before the water, fish and smaller debris are returned to sea via the Fish Return (HCF) system. The principle aim is to remove debris that is large enough to block either the Archimedes' screw or the Fish Return (HCF) system gutter and tunnel.
- 15.1.8 The rack spacing for the filtering debris recovery pit (HCB) raking system is set at 200 mm.
- 15.1.9 The setting of the bar spacing on the filtering debris recovery pit (HCB) debris (trash) rack is a process of constrained optimisation. It must be set low enough to provide adequate protection for the Archimedes' screw and Fish Return system (HCF) tunnel against the risk of blockage by items of debris, whilst remaining large enough to maximise the return of fish to sea. As an empirical rule, the bar spacing must be at least 3 – 6 times lower than the diameter of the tunnel.
- 15.1.10 As described elsewhere, the design of fish return (HCF) comprises a 651 mm internal diameter tunnel from each unit, merging to form a common outfall tunnel of 938 mm internal diameter. For these two tunnel diameters, 200 mm provides a ratio of 1:3.3 (i.e. $3.3 \times$ the tunnel diameter) and 1:4.7 ($4.7 \times$ the tunnel diameter), respectively.
- 15.1.11 For information, increasing the bar spacing to 270mm (i.e. the same horizontal width as the bar spacing of the intake heads) would only provide $2.4 \times$ the diameter of the smaller, 651 mm gutter which is not protective. In any case, although the horizontal spacing of bars at the intake is 270 mm, the vertical spacing is 2 m so debris much longer than the horizontal width could still enter the system (although it is acknowledged that transmittal of very large material to the filtering debris recovery pit (HCB) is

constrained to some extent by the parameters of the forebay raking system and Cooling water pump house gutters).

- 15.1.12 The trash rake itself, in the filtering debris recovery pit (HCB) will be a 'Bosker'- type rake (see Figure 50). The rake traverses a monorail and ascends/descends on a cable winch. The rake cleans the trash rack on the down stroke by gravity with the grab in the open position. Once fully descended, the grab snaps shut with the aid of hydraulic actuators and then ascends back to the top. The rake then traverses the monorail across to the platform and deposits the contents into a skip, which is evacuated by lorry once full. The rake will operate on both head loss and an adjustable timer.



Figure 50: Bosker'- type rake

- 15.1.13 Material recovered by the rake, including any fish impinged on the rack, will be disposed of to land. This is normal practice.
- 15.1.14 Although the Archimedes' screw design meets best practice (see Ref [4]), the requirement of the need to elevate the water from the filtering debris recovery pit (HCB) in the first place, as opposed to discharging back to sea direct from the filtering debris recovery pit (HCB) basin requires justification.
- 15.1.15 In order to evacuate the flow from the filtering debris recovery pit (HCB) to sea by gravity, the water level needs to be high enough above sea level to overcome the head losses generated by the discharge.
- 15.1.16 The use of Archimedes' screws to raise water in the filtering debris recovery pit (HCB) discharge to sea by gravity can be ensured for all current and projected sea levels (Ref [11]).
- 15.1.17 A discharge direct to sea from the filtering debris recovery pit (HCB) is limited because the maximum achievable water level is limited by the overflow back to the forebay

(HPF) at 9.53 m ODN, which is needed to protect safety classified equipment in HP against internal flooding.

- 15.1.18 Taking into account the constraints (flow rate range, velocity, etc) governing gravitational discharge to sea, a direct discharge to sea would incur a head loss of at least 3.17 m (depending on the design) at the maximum flow rate (which itself is associated with high sea levels and fauna and flora clogging of the drum screens and band screens). Under such conditions, a direct discharge to sea, without recirculation of water to the forebay (HPF), is only possible for sea levels below 6.36 m ODN (9.53 m ODN – 3.17 m ODN).
- 15.1.19 At current sea levels, the maximum allowable filtering debris recovery pit (HCB) level (without incurring overflow to the forebay (HPF)) of 6.36 m ODN will be exceeded around once a month. Furthermore, this may become more frequent throughout the Hinkley Point C's operational lifespan due to rising sea levels associated with predicted Climate Change.
- 15.1.20 Therefore, with a discharge direct to sea, overflow from filtering debris recovery pit (HCB) to the forebay (HPF) would occur at least once per month, and possibly increasing over time.
- 15.1.21 Recirculation of water from the filtering debris recovery pit (HCB) to the forebay does not impact nuclear safety *per se*, but it does represent a frequent and unnecessary challenge to the potential of a main cooling water (CRF) pump trip (which is a Category 1 safety function and a notifiable event), therefore, posing an unacceptable risk to plant operability.
- 15.1.22 Combining a direct discharge from filtering debris recovery pit (HCB) with an Archimedes' screw discharge for periods where there is insufficient head for a direct discharge would have significant impacts on design, cost, constructability, operability and maintenance burden. However, a design combining both these elements is considered to provide very limited (if any) benefit over a discharge to sea from a shrouded (best practice) Archimedes' screw and so would be disproportionate.
- 15.1.23 Impact Assessment
- 15.1.24 The design of the filtering debris recovery pit (HCB) largely meets the Environment Agency criteria (Ref [2] [3]).
- 15.1.25 However, the filtering debris recovery pit (HCB) raking system does warrant further examination in respect of its potential to prevent large fish from returning to sea. As described previously impingement predictions for Hinkley Point C were made by applying survival predictions to scaled-up impingement data from Hinkley Point B. As size data are available within the Hinkley Point B dataset, refinement of those predictions can be made (Ref [22]).
- 15.1.26 From Table 23, it can be seen that the largest expected cod and sole at Hinkley Point would all pass through the 200mm HCB trash rack but, in principle, some plaice and thornback ray may not (Ref [22]).

Table 23: Maximum expected fish sizes in the Celtic Sea area (Ref [22])

Species	Adult Maximum Total Length (TL) cm	Maximum Width mm	Data source	Age that the species is expected to leave nursery areas
Cod	109 - 113	174 - 183	Fishbase 2000-2001 unsexed trawl data Celtic Sea, ICES Division VII e - k	2 to 3 years old
Sole	51.5	145	Fishbase: 2000-2001 unsexed trawl data Celtic Sea, ICES Division VII f & g E&W	2 to 3 years old
Plaice	50.5 - 58.5	213 - 246	Fishbase 2000-2001 unsexed trawl data Celtic Sea, ICES Division VII f & g	-
Thornback Ray	102.5	675	Fishbase (1986-) E&W	2 years. However, adults move into shallow water (<10m) in spring – late summer to mate

- 15.1.27 However, based on the CIMP survey data conducted at HPB, all fish entrained at HPC will be small enough to pass through the HPB 200 mm rack (Ref [22]).
- 15.1.28 Regardless, the skip receiving debris from the HCB rack and raking system will be examined (as much as is safe and feasible to do so) during the routine impingement monitoring programme.
- 15.1.29 Conclusion
- 15.1.30 The design of the Hinkley Point C filtering debris recovery pit (HCB) adheres to Environment Agency criteria and recommendations (Ref [2] [3]).
- 15.1.31 The use of an Archimedes' screw is justified and considered best practice for elevating fish.
- 15.1.32 The bar spacing of the raking system is justified and, although has the potential to remove very large fish from the system, is considered to have minimal environmental impact.
- 15.1.33 Given the above, and the use of generic survival predictions for fish travelling through Fish Recovery and Return (FRR) systems, the Hinkley Pointy C filtering debris recovery pit (HCB) design does not alter the assessments undertaken in support of the application for development consent.

16 RETURN TO SEA (HCF)

16.1.1 Compliance with Environment Agency Criteria

16.1.2 For the return to sea element of Fish Recovery and Return (systems) the Environment Agency (Ref [2] [3]) provides the following criteria and recommendations:

- (i) Fish should not be returned in the main cooling water (CRF) outfall;
- (ii) Fish should be returned to an location that is below the Lowest Astronomical Tide (LAT) mark to ensure that fish are returned to the sub-tidal environment at all stages of the tide;
- (iii) The location of the outfall should not be in an area where entrapment into the intake is likely;
- (iv) Consideration should be taken for the potential for predation of the returned fish by birds and marine mammals;
- (v) Consideration should also be taken into account of local beaches such that any dead fish returned to the sea are not washed up in large numbers on local beaches, particularly near bathing waters.

16.1.3 Other 'general' criteria also apply:

- (i) Bends and drops in the collection gutter network should be minimised;
- (ii) Gutters should be smooth, with any joints properly grouted and finished so there are no snags;
- (iii) The main return gutter should be at least 500 mm in diameter;
- (iv) Bends for gutters > 400 mm diameter should be swept and have a minimum radius of at least 1.5 times the gutter diameter;
- (v) The gradient /slope of launders that feed into horizontal bends should be no more than 1:50 (i.e. no steeper than 1:50 (or $\leq 2\%$));

16.1.4 The Hinkley Point C Fish Return (HCF) system, which transfers fish from the point they exit the filtering debris recovery pit (HCB) along guttering and then back to sea via a tunnel and outfall head, is compliant with the Environment Agency (Ref [2] [3]) guidance for these aspects of the overall Fish Recovery and Return (FRR) system, as well as other more general criteria:

- (i) a dedicated return tunnel is provided to return the fish to sea;
- (ii) the return outfall exits at -6.71 m ODN which is below the lowest astronomical tide (LAT) mark and so will return fish to the sub-tidal at all states of the tide;
- (iii) The Fish Return (HCF) system outfall location is approximately 450 m offshore, compared with the Hinkley Point C intake location positions approximately 3 km offshore and so there is no immediate risk of returned fish being re-entrapped into Hinkley Point C. Assessment of the potential for returned fish to be entrapped in

the cooling water intake of the Hinkley Point B cooling water system has been analysed and been shown not to be a significant risk (Ref [26])²¹;

- (iv) Assessment of the risk of predation is complex; however, by discharging to the sub-tidal will mitigate predation from birds and there are not significant numbers of marine mammals present in the discharge location area (Ref [26]).
- (v) The bathymetry local to the area selected for the Fish Return (HCF) outfall has also is considered suitable for fish return, being deep enough such that predation from birds is unlikely. The seabed below the outfall point descends relatively quickly to deeper waters to allow fish to move away from the outfall (Ref [26]). The precise bathymetry will be determined as part of the installation method development.
- (vi) There are no bathing waters immediately adjacent to the outfall location;
- (vii) the use of bends has been minimised, but some bends are necessary to channel the flow to the discharge tunnel;
- (viii) there are no vertical drops in the Fish Return (HCF) system;
- (ix) the main gutter is 651 mm in diameter;
- (x) minimum bend radii is than 3.25 m (therefore, 5× the gutter radii);
- (xi) the Fish Return (HCF) system tunnel is 938 mm diameter;
- (xii) the slopes of the Fish Return (HCF) system gutters are 0.65% and 0.56% for Units 1 and 2, respectively.

16.1.5 Justification

16.1.6 Although the Fish Return (HCF) system is compliant with Environment Agency criteria, certain aspects (including the long lengths of the gutters and the return tunnel hydraulics) warrant further explanation (if not necessarily justification).

16.1.7 As described in other sections of this report, the Fish Recovery and Return (FFR) system is constrained by the very large tidal range at Hinkley Point. To discharge the fish back to sea under gravity, without risk of recirculation from the filtering debris recovery pit (HCB) the water and fish need to be elevated to 12.8 m ODN; the outfall needs to discharge at below Lowest Astronomical Tide (LAT) at -6.09 m ODN. So the fish need to be dropped almost 19 m between the exit from the filtering debris recovery pit (HCB) and the discharge point approximately 450 m offshore.

16.1.8 The Fish Return system (HCF) tunnel achieves much of the vertical drop, being directional-drilled under the shore, however, there is a need to transfer the fish from the filtering debris recovery pit (HCB) (at 12.8 m ODN) to the entrance to the Fish Return (HCF) tunnel (at 11.51 m ODN)

²¹ The potential for siltation to occur at the outfall structure was also considered and the location was chosen to mitigate this.

- 16.1.9 To achieve the transit between the filtering debris recovery pit (HCB) and the Fish Return (HCF) system outfall, various options of dropping the fish several metres over a short horizontal distance were assessed, but none was able to comply with power dissipation or other fish protection criteria. Therefore single gutter runs have been selected but, to achieve the necessary vertical drop, the gutter runs need to be long (197 m and 231 m long for Units 1 and 2, respectively).
- 16.1.10 The longer gutters without any rapid drops are considered better for fish protection. The gutters will be covered to prevent predation from birds, with inspection hatches at every bend and no further than 100 m apart on straight sections (these distances are industry best practice for maintenance access to buried pipework).
- 16.1.11 Flow velocities in the Fish Return (HCF) tunnel, in the non-flooded part of the tunnel (i.e. where flow will be as free surface flow), will be up to a maximum of 9.5 m s^{-1} (at the steepest part of the tunnel where the gradient is 13%).
- 16.1.12 Under free-flow, the draft of water is 170 mm to 220 mm and therefore sufficient to keep the fish submerged.
- 16.1.13 The gradient that the interface between free surface flow and closed conduit flow (i.e. where the flowing water from the Fish Return (HCF) system meets the tidal level in the flooded tunnel), for Lowest Astronomical Tide (LAT), is 12 %. The free flow velocity at this point is around 9.1 m s^{-1} ; at this point, water and fish will decelerate to the closed conduit flow of around 1.8 m s^{-1} .
- 16.1.14 As stated previously, power dissipation cannot be readily calculated as there is no definitive volume of the receiving water. In this instance, shear stress is a better indicator of the potential impacts on the fish.
- 16.1.15 At the maximum velocity of 9.5 m s^{-1} shear stress may be close to 1600 N m^{-2} . However, there is not a single relationship between shear stress and velocity, as it depends on the roughness (Manning coefficient) of the surface (A. Turnpenny, pers. comm.). The tunnel lining will be a HDPE 'sleeve' which will be very smooth (Strickler coefficient = $100 \text{ m}^{1/3} \text{ s}^{-1}$ which is high and indicative of a very smooth surface).
- 16.1.16 Impact Assessment
- 16.1.17 The Fish Return (HCF) system is compliant with Environment Agency criteria and, given the use of generic survival predictions for fish travelling through Fish Recovery and Return (FRR) systems, the Hinkley Pointy C Fish Return (HCF) system design does not alter the assessments used for the Development Consent Order (DCO).
- 16.1.18 A maximum velocity of 9.5 m s^{-1} in the Fish Return (HCF) tunnel is faster than the fish would normally experience in that natural environment. Shear stress at this speed may be close to the 1600 N m^{-2} shear stress threshold for damage (see also Table 17) (A. Turnpenny, pers. comm.). However, any risk of injuries such as descaling would be greatly mitigated by ensuring that there is a smooth finish (A. Turnpenny, pers. comm.).
- 16.1.19 The tunnel lining will be HDPE which is very smooth (Strickler coefficient = $100 \text{ m}^{1/3} \text{ s}^{-1}$ which is indicative of a very smooth surface) and so is expected to greatly mitigate any risk of injury to fish from shear stress (A. Turnpenny, pers. comm.).

- 16.1.20 Given that a velocity of 9.5 m s^{-1} is a maximum that will only be encountered during certain tidal states, and the fact that even at this maximum effects of shear stress are expected to be low due to the very smooth surface of the tunnel lining, impacts of fish travelling through the Fish return (HCF) tunnel are expected to be very low.
- 16.1.21 The total time for a fish to enter the intake head, travel the Fish recovery and Return (FRR) system and be returned to sea varies according to which route they take, the quickest potential route being fish recovered on the trash racks (if recovered immediately) and the longest being fish recovered by the band screens on low tides.
- 16.1.22 Total transit times are:
- (i) 48 minutes for fish recovered by the debris (trash) rakes (plus the time between raking cycles);
 - (ii) 63 to 89 minutes for fish recovered by the band screen;
 - (iii) 48 to 53 minutes for fish recovered by the drum screen.
- 16.1.23 Transit times for individual sections are provided in Table 24.

Table 24: Transit times through each section of the Hinkley Point C cooling water infrastructure

Section	Flow Path	Speed	Transit time
Intake Heads	24 m (17 + 7)	1	24 s
Intake Shafts	20	2	10 s
Intake Tunnels	3500m	2.3	25 mins 22 sec
Forebay			6 min
HP	Debris Rack		4 mins (plus cycle interval)
	Band screen		19 – 45 mins
	Drum screen		4 – 9 mins
HCB			2 mins
HCF	231 m	2.3 m s^{-1}	9 mins
	662	1.5 m s^{-1}	

17 OUTFALL HEAD

17.1.1 Compliance with Environment Agency Criteria

17.1.2 For the main cooling water (CRF) outfall head, the Environment Agency provides the following criteria and recommendations (Ref [2] [3]):

- (i) The outfall location should not cause impacts (i.e. from temperature increase) to sensitive habitats or biotopes; no sensitive habitat or biotope should be exposed to the plume for sufficiently long, or often or at temperature sufficient to cause harm;
- (ii) Similar consideration should be made to the release of biocide reagents or other potential toxicants;
- (iii) The outfall should not be positioned where attachment of the plume to the shore will occur;
- (iv) In estuaries, the outfall locations should not be positioned where the plume might occupy more than 25 % of the channel cross-section for more than 5% of the time (allowing for some spread at slack water);
- (v) The outfall should be positioned in sufficient depth of water such that the plume does not attach to the seabed, to ensure efficient release of heat from the plume;
- (vi) The outfall screen only needs to be a coarse screen, for example, 40 mm diameter bars with a 250 mm pitch, to prevent accidental entry of, for example, marine mammals when the system is not operating;

17.1.3 It should be noted that, apart from potential plume impacts, the outfall head structure location and design does not impact fish; in particular, it does not impact fish passing through the Fish Recovery and Return system (FRR) as these not returned to sea in the main cooling water outfall.

17.1.4 The Hinkley Point C outfall complies with all of these criteria and recommendations apart from the bars across the outfall head aperture:

- (i) The outfall location is deliberately 2km offshore and located in an area where the thermal plume will not cause significant impacts on sensitive habitats or biota, in particular the intertidal mudflats to in Bridgwater Bay (to the west of the outfall location) which supports large numbers of birds (part of the Severn Estuary Special Protection Area; SPA) (Ref [27]);
- (ii) The same assessment applies to the chemical plume (Ref [28]);
- (iii) The outfall is located approximately 2 km offshore; attachment to the shore cannot occur (Ref [28]);
- (iv) The discharge plume does not occlude either the Bristol Channel or the River Parrett;
- (v) The outfall is positioned in deep water (approximately 14 m at high tide); attachment of the plume to the seabed will not occur;
- (vi) The outfall structure does not have bars across its aperture.

17.1.5 Justification

- 17.1.6 The location and design of the Hinkley Point C main cooling water outfall are mostly compliant with Environment Agency criteria and guidance (Refs [2] [3] [27] [28]).
- 17.1.7 The only non-compliant element is the lack of bars across the outfall aperture. The Hinkley Pint C outfall structure is based on other EPR outfall head designs. It lacks bars across the outfall aperture because it is expected to always have cooling water flow being discharged.
- 17.1.8 The cooling water discharge tunnel at Hinkley Point is shared between two EPR units and so even when one unit is not operating (for maintenance purposes) the other unit will still be operating and so discharging water via the outfall (at around $65 \text{ m}^3 \text{ s}^{-1}$. Only when neither unit is operational (such as a two unit outage, scheduled for once every 10 years) would there be no main cooling water (CRF) discharge from the outfall, but even then there would be some discharge from the other cooling water units. For this reason, it is not considered necessary to have bars across the outfall aperture.

17.1.9 Impact Assessment

- 17.1.10 The main cooling water (CRF) outfall for Hinkley Point C is mostly compliant with the criteria and recommendations of the Environment Agency. Full details are provided in Ref [28] and the Development Consent Order (DCO) Environmental Statement (ES).
- 17.1.11 Bars across the outfall head aperture are not considered necessary as flow will almost always be discharging through the outfall and thus preventing marine mammals (or humans) from entering the system via this route. This does not affect the impact assessment.
- 17.1.12 Therefore, the design and location of Hinkley Point C cooling water outfall remains consistent with the assessments used for the Development Consent Order (DCO).
- 17.1.13 The potential for monitoring of fish returned to sea will be considered as part of the monitoring plan to be developed for DCO Requirement CW2 and Marine Licence Condition 5.2.35.

18 SUMMARY

- 18.1.1 This document provides the design of the Hinkley Point C cooling water infrastructure, with particular reference to the Fish Recovery and Return (FRR) system.
- 18.1.2 As required by the Development Consent Order (DCO) and Marine Licence Condition 5.2.31, the system has been designed in accordance with Environment Agency guidance (Ref [2] [3]).
- 18.1.3 Where compliance with Refs [2] and [3] has not been possible, this document provides the justification and provides an assessment in terms of whether / how that non-compliance might affect the impact assessments made for fish during in the Environmental Impact Assessment (EIA) and Habitats Regulations Assessment (HRA).
- 18.1.4 Tables 25, 26 and 27 provide summary information of compliance with Environment Agency guidance (Refs [2] [3]):
- (i) Table 25 shows compliance of the system with defined criteria;
 - (ii) Table 26 shows the provides details of all the drops in the system;
 - (iii) Table 27 shows each part of the system with summarised compliance criteria.
- 18.1.5 As detailed in sections 11 – 17, in many cases where the Hinkley Point C design does not meet Environment Agency criteria the impact cannot be applied to the impingement predictions because of the use of generic survival rates from the Environment Agency's own guidance (Ref [3]).
- 18.1.6 However, non-compliance with these criteria is considered not to be significant (nor alter the impingement predictions) for two reasons:
- (i) The generic figures provided by the Environment Agency provides a simple single figure for survival of different fish types through fish recovery and return systems. Individual parameters have not been assessed, nor necessarily met the best practice now defined by the Environment Agency; and,
 - (ii) There has been a great deal of improvement in the design of fish protection measure at power stations. The Hinkley Point C design has been informed by operational experience (OPEX) from other installations and benefits from the latest understanding of fish recovery and design performance. Non-compliance with certain criteria in certain part of the system is mitigated by modern design principles throughout the plant.
- 18.1.7 One aspect of the impingement predictions used in the Hinkley Point C Development Consent Order (DCO) Environmental Impact Assessment (EIA) or Habitats Regulations Assessment (HRA) can be examined further. The impingement predictions were based on scaled-up flow rates for the fish impinged at Hinkley Point B. That assumed a coarse filtration (SEF) screen bar spacing of 75 mm. As the Hinkley Point C design has coarse filtration (SEF) bar spacing of 50 mm the reduction in number of fish exiting the forebay (i.e. those fish able to pass through a 75 mm rack but not a 50 mm rack. Fewer numbers of sole, cod, plaice, thornback ray and sea lamprey are predicted to survive, but the numbers are not considered ecologically significant. These losses are also mitigated to some extent because the Hinkley Point C raking system returns fish to the

sea (via the filtering debris recovery pit (HCB)) where as Hinkley Point B has no raking system.

18.1.8 In conclusion:

- (i) the Hinkley Point C cooling water system (including the fish recovery and return (FRR) system) largely meets the necessary Environment Agency criteria (Ref [1] [2]);
- (ii) where the design does not (and, more accurately cannot) meet the criteria full justification has been provided;
- (iii) despite not meeting all of the Environment Agency criteria, the design of the Hinkley Point C cooling water system (including the fish recovery and return (FRR) system) remains consistent with the impingement predictions used in the application for development consent Environmental Impact Assessment (EIA) or Habitats Regulations Assessment (HRA).

Table 25: Environment Agency criteria (Ref [2] [3]) and assessment of Hinkley Point C Fish Recovery and Return (FRR) system.

	Description	Hinkley Point C Design
1	The power dissipation (turbulence) must be $\leq 100W m^{-3}$	All drops are $100 W m^3$ or less.
2	Sprays used for washing fish from the screens must operate at ≤ 1 bar pressure.	All sprays used for fish removal operate at 1 bar. Low (3.5 bar) and High (6.5 bar) pressure sprays are used to flush debris
3	Wash-water flow must be continuous.	Wash-water flow is continuous and supplemented in places to improve flushing along hoppers and gutters.
4	High-pressure backwashing should discharge to the fish return hoppers (or, at least, have the ability to be re-directed to the fish return launders when required).	ALL material washed from the trash racks, band screens and drum is transferred to the HCB building (and thus to the FRR)
5	All fish handling gullies must have a smooth finish, including the joints, so that there are no rough edges	All fish handling gutters will smooth. High density polyethylene (HDPE) will be used to line gutters. HDPE is very smooth, with a Strickler coefficient of $100 m^{1/3} s^{-1}$.
6	Gullies should be covered, but accessible. Areas where fish may collect should be protected from bird predations.	The fish return gutters will be covered with access chambers for maintenance.
7	All fish handling gullies must be at least 0.3 m diameter, in section; the return tunnel must be at least 0.5 m diameter, in section.	All gutters in the cooling water pump house are 0.4 m diameter: Fish return gutters (pipes) are 0.65 m Fish return tunnel is 0.94 m
8	All bends in the gullies / launders, both horizontal and vertical, must be swept, with radii of at least 3 m.	All gutters and pipes are at least 400 mm in diameter and, therefore, another criterion of " $\geq 1.5 \times$ the diameter" can be applied (Ref [2] [3]). All pipes and gutter bends comply with this criterion. There are no vertical bends.
9	The gradient /slope of launders that feed into horizontal bends should be no more than 1:50 (i.e. no steeper than 1:50 (or $1 \geq 50$)).	The only horizontal bends in the system are in the cooling water pump house (HP) (individual drum screen collection gutters) and the Fish Recovery and Return (FRR) system gutters. The gradient of the drum screen individual collection gutters are 2.0% (1:25) and the Fish Recovery and Return (FRR) system gutters are 0.56 and 0.65% ($< 1:50$).
10	The screen mesh must be smooth, woven stainless steel or plastic, and have a mesh size $\leq 6mm$.	The drum screen is woven stainless steel, with a mesh size of 5mm.
11	The fish buckets must be designed to retain water and minimise the possibility of fish falling out.	Detailed fish bucket design is not yet available, but the basic design is considered best available based on supplier and

	Description	Hinkley Point C Design
	Special consideration should be made to sinuous fish such as eels as these are predicted to be important at HPC.	operational experience.
12	The geometry of the collecting hoppers should ensure that fish washed off the screens cannot fall back into the screenwell.	The collection hoppers have been designed specifically to retain eels. The geometry of the buckets and hopper are constrained to some extent by size of the drum screens.
13	The drum screens must rotate at a constant elevation of $\geq 1.5 \text{ m min}^{-1}$	Minimum rotation speed of drum screens will be 2.5 m min^{-1} Minimum rotation speed of band screens will be 0.5 m min^{-1}
14	A separate tunnel must be provided to return the fish to sea.	A separate tunnel to return the fish to sea (0.94m diameter) will return the fish to sea below the Lowest Astronomical Tide (LAT) tidal mark.

Table 26: Summary of vertical drops in the Hinkley Point C Fish Recovery and Return (FRR) system.

Location	Description	Height of drop	Power dissipation
Cooling water pump house (HP)	Drop from debris (trash) rake into collection gutter (collection gutter slopes down to filtering debris recovery pit (HCB) so drop height increases closer to HCB)	240 mm to 670 mm	N/A Power dissipation calculation not appropriate for gutters. Fish will not take refuge / linger in these areas and the volume of the receiving pool cannot be calculated
	Drop from band screen bucket into in to collection gutter	approx. 0.5 m (free fall distance); to be confirmed detailed design of interface in reality the fish will slide down across the inverted screen mesh and will not be in free fall.	N/A
	Drop from drum screen bucket into collection gutter	0.26 – 0.41m	N/A
	Drop from drum screen individual collection gutters (on sides furthest from HCB) to common fine filtration (CFI) gutter (see Figure 22 and Table 8)	$\leq 0.03 \text{ m}$	N/A
Filtering debris recovery pit (HCB)	Drop from coarse filtration (SEF) gutter from cooling water pump house	0 m (gutter invert is same as water level)	16 - 33
	Drop from fine filtration (CFI) gutter from cooling water pump house	0 m (gutter invert is same as water level)	680-100
	Drop from top of Archimedes' screw into basin.	To be confirmed.	Suppliers design is constrained to comply with 100 W m^3 .

Table 27: Summary of the compliance of separate Hinkley Point C Fish Recovery and Return (FRR) system with the Environment Agency criteria (Ref [2] [3]).

Component	Criterion	Compliance	Section	Justification
Intake head	Location	Yes	4.2	-
	Low velocity, side entry design	Yes	4.3	-
	Intake velocity	No		11.2
Intake Shaft	N/A	Yes	4.4	12.1.2
Intake Tunnel	N/A	Yes	4.5	12.1.2
Forebay	N/A	Yes	5	13.1.4 13.1.11
	Cooling water pump house			
Coarse filtration	Undefined	-	6.1	14.1
Band screens	Continuous	Yes	6.2	
	Speed	No	6.2	14.2
	Mesh size	Yes	6.2	-
	Low pressure sprays	Yes	6.2	-
	No biocide	Yes	6.2	-
	Geometry	Yes	6.2	-
Drum screens	Continuous	Yes	6.3	-
	Speed	Yes	6.3	-
	Mesh size	Yes	6.3	-
	Low pressure sprays	Yes	6.3	-
	No biocide	Yes	6.3	-
	Geometry	Yes	6.3	-
Gutters	Drops minimised	Yes	6.4	-
	Smooth	Yes	6.4	-
	Diameter (>300mm)	Yes	6.4	-
	Bends (swept; >1.5x radius for 400 mm radius)	Yes	6.4	-

Component	Criterion	Compliance	Section	Justification
	gutter)			
	Gradient (max 1:50)	No	6.4	-
	Power dissipation	Yes	6.4	-
Filtering debris recovery pit (HCB)	Minimised drops	Yes	7	-
	Power dissipation	Yes	7	-
	Minimum depth	Yes	7	
	Raking - undefined		7	15.1.5
	Archimedes' screw design	Yes	7	-
Return to sea	Dedicated tunnel	Yes	8	-
	Outfall location	Yes	8	-
	Minimised bends and drops	Yes	8	-
	Gutter diameter	Yes	8	-
	Gradient	Yes	8	-
Cooling Water Outfall	Location	Yes	9.5	-
	Screen	No	9.5	17.1.5

19 REFERENCES

- [1] Hinkley Point C Environmental Statement (2011). Main Development Site: Chapter 2 – Site Description. EDF Energy.
- [2] Environment Agency 2005 *Screening for Intake and Outfalls: a best practice guide*. Environment Agency Science Report SC030231/SR3. Environment Agency, Bristol UK.
- [3] Environment Agency 2010 Cooling Water Options for the New Generation of Nuclear Power Stations in the UK SC070015/SR3. Environment Agency, Bristol UK.
- [4] Environment Agency 2011 The Eel Manual
- [5] Jacobs (2010) Hinkley UK EPR - Intake and Outfall Heads - Phase 2 Report - Final
- [6] Trash Rakes – Description of fish recovery method of operation and key features (HPC-UK3511-U9-SEF-RET-000003) EDF, CNEPE
- [7] Hinkley Point C: Justification of the Band screens design (HPC-CNEPEX-AU-HP7-STR-200037). EDF, CNEPE
- [8] Drumscreen – Description of fish recovery method of operation, key features and OPEX references (HPC-UK3511-U9-CFI-RET-000002). EDF, CNEPE
- [9] HPC FFR System: Strategy for handling fish and debris and optimisation of cooling water pump house gutter hydraulics. EDF, CNEPE.
- [10] HCB Final Design Report (HPC-CNEPEX-AU-HCB-RET-20004). EDF, CNEPE
- [11] Analysis of design concepts for the discharge to sea from HCB (HPC-ETSIMX-AU-HCB-REP-200049). EDF, CNEPE
- [12] HCF Basic Design Report (HPC-CNEPEX-U9-HCF-NOT-200461). EDF, CNEPE
- [13] Hinkley Point C Environmental Statement (2011). Main Development Site: Chapter 19 – Marine Ecology. EDF Energy
- [14] Numerical and physical modelling of the Hinkley Point C intake and outfall structures. Task 1 – Physical modelling of flows at intake heads. HR Wallingford. Hydraulics Research Wallingford.
- [15] Hinkley Point Site: Oceanographic Survey; Hinkley Point. BEEMS Technical Report 052 Ed2, CEFAS.
- [16] HPC Intake and Outfall Heads ALARP and BAT Review (HPC-NNBOSL-U9-HPT-RET-100000). NNB GenCo (HPC) Ltd
- [17] Hinkley Point C: A synthesis of impingement and entrainment predictions for NNB at Hinkley Point. BEEMS Technical Report TR148 Ed 2, CEFAS.
- [18] Hinkley Point C: Assessment of Effects of CW Intake Velocity on Fish Entrapment Risk at Hinkley Point. BEEMS Technical Report 117 Ed2, CEFAS.
- [19] Hinkley Point 'C' Cooling Water Intake Velocities in Relation to Sprat Swimming Performance (Turnpenny Horsfield Associates). Report No: 546N0203

-
- [20] Numerical and physical modelling of the Hinkley Point C intake and outfall structures – CTR24 Assessment of hydraulics impact on fish for two layouts of the forebay (HPC-ETGCXX-AU-HPF-NOT-200047). Hydraulics Research Wallingford.
 - [21] Hinkley C Forebay Fish – Hydraulic Modelling Assessment (Turnpenny Horsfield Associates). Report No: 546N0302.
 - [22] Hinkley Point Site: Updated impingement predictions based upon the detailed design of the cooling water system. BEEMS Technical Report TR409, CEFAS.
 - [23] Survivorship trial of the fish return system at Sizewell B Power station. Fawley Aquatic Research Labs, 1994.
 - [24] Hinkley Point Site: Hinkley Point Nearshore Communities: Results of the 2 m Beam Trawl and Plankton Surveys 2008–2010. BEEMS Technical Report TR083Ed3, CEFAS
 - [25] Hinkley Point Site: Benthic-pelagic invertebrate populations around Hinkley Point C. BEEMS Technical Report TR350, CEFAS.
 - [26] Hinkley Point Site: Modelling of the optimal position of a fish recovery and return system for Hinkley Point C. BEEMS Technical Report 197, CEFAS.
 - [27] Hinkley Point C: Hinkley Point Marine Ecology Synthesis Report. BEEMS Technical Report 184, CEFAS.
 - [28] Hinkley Point Site: Predicted Effects of NNB on Water Quality at Hinkley Point. BEEMS Technical Report 186, CEFAS.

20 APPENDICES

APPENDIX A:

SELECTED INTAKE HEAD MODEL OUTPUTS

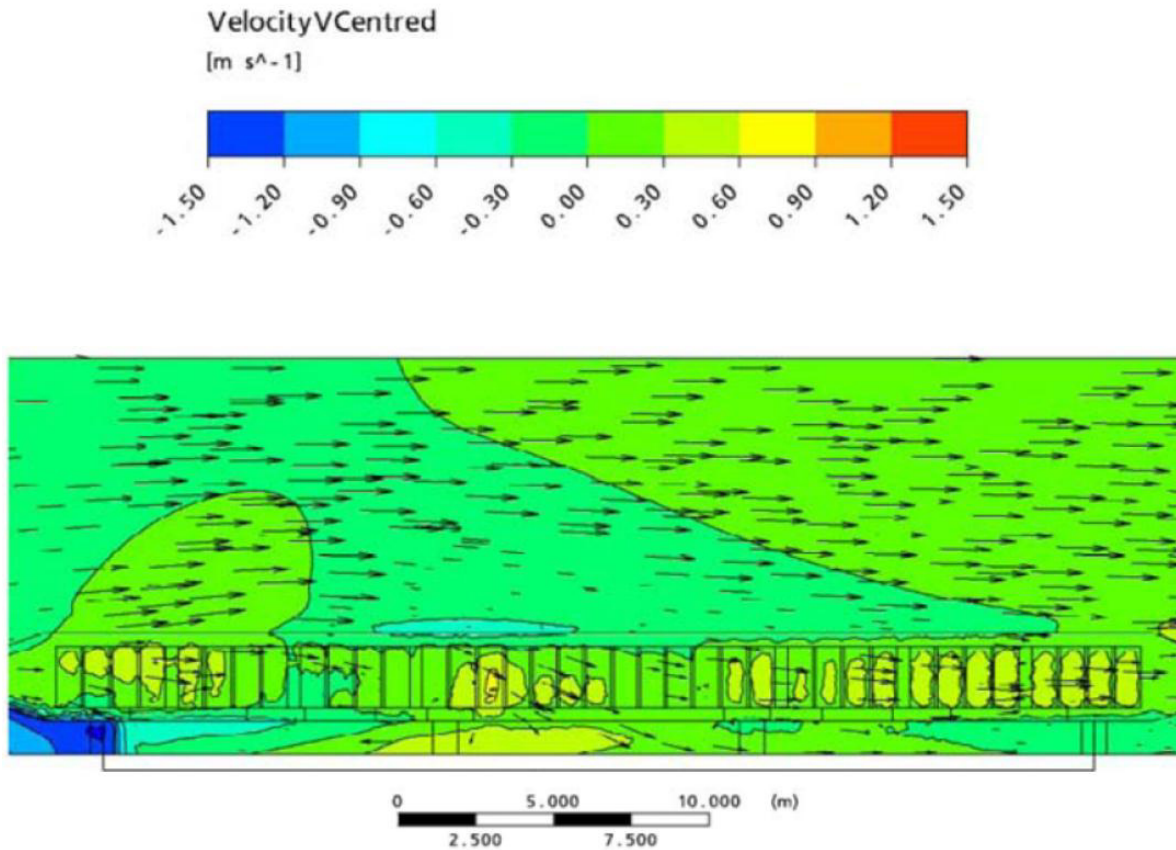

Figure A1: Modelled velocity contours across the lateral trash-rack face for the Jacobs Final Design intake in a 1.5 m s⁻¹ tidal flow.

Negative values indicate flow exiting structure (from Jacobs, 2010).

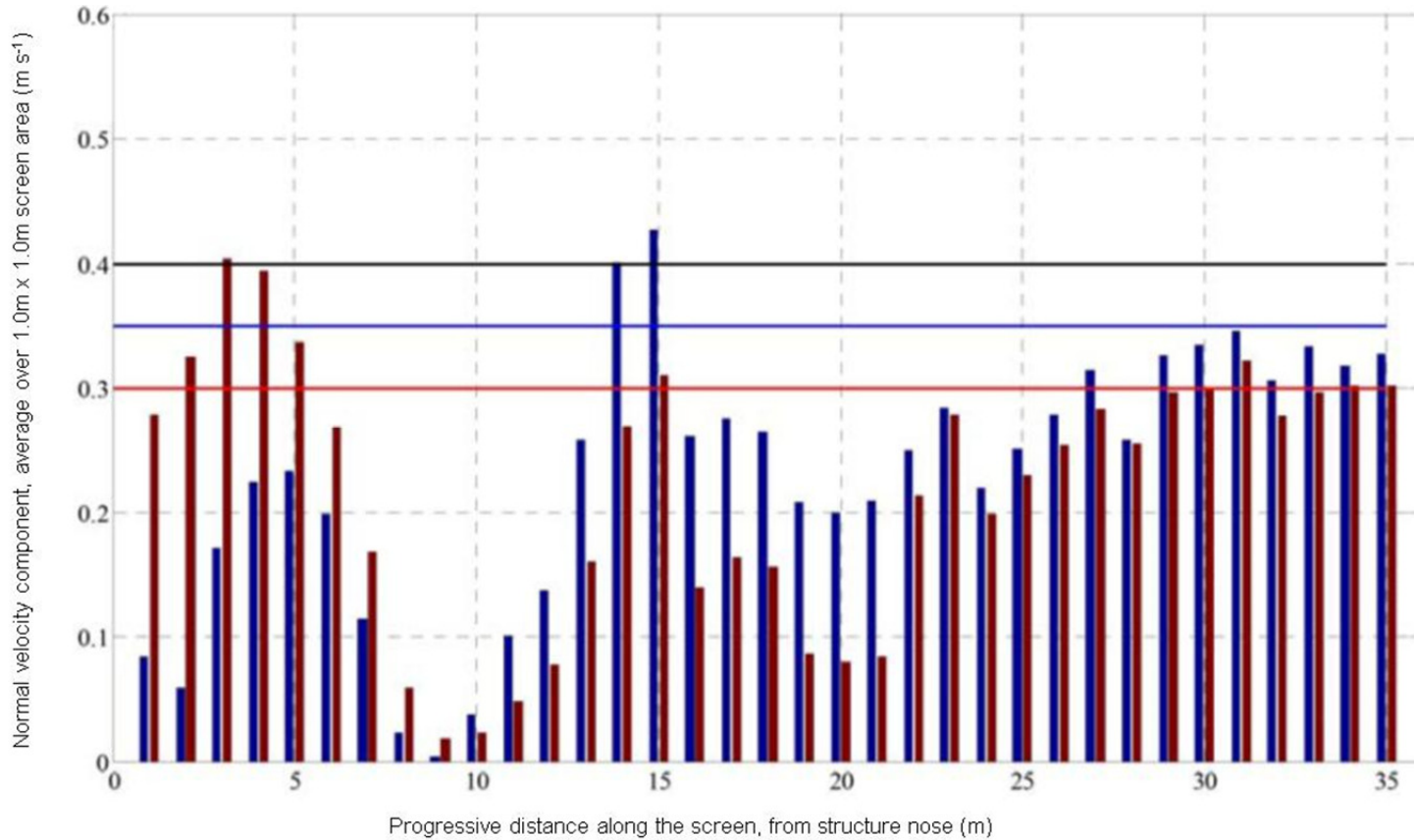

Figure A2: Bar chart showing modelled velocity contours across the lateral trash-rack face for the Jacobs Final Design intake (target value = 0.3 m s^{-1}) for a tidal velocity of 1.5 m s^{-1} . No negative values are present in this case.

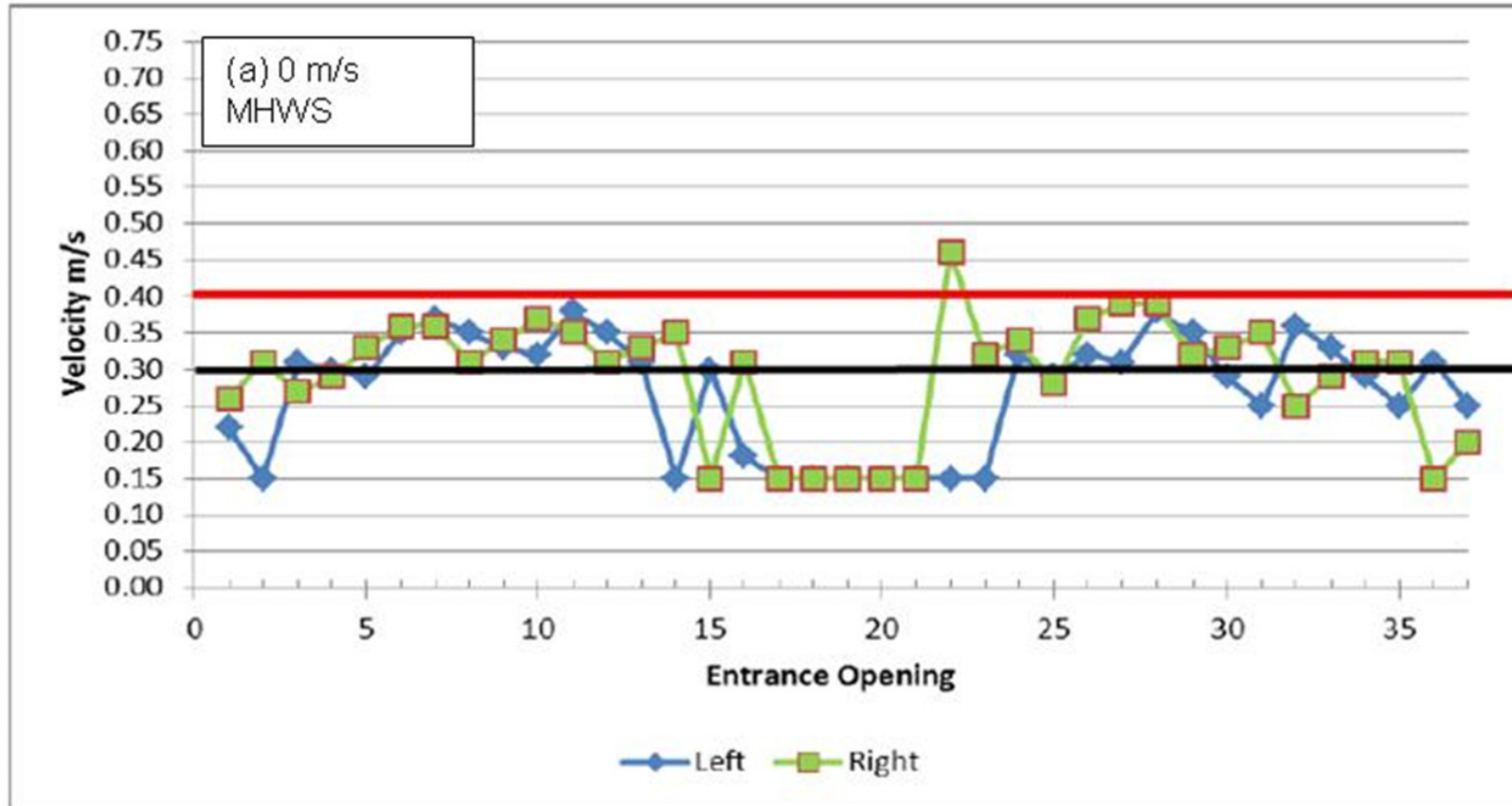

Figure A3 Escape velocities measured at points along the screen face in physical hydraulic model at 0 m s⁻¹ tidal flow (Ref [18])

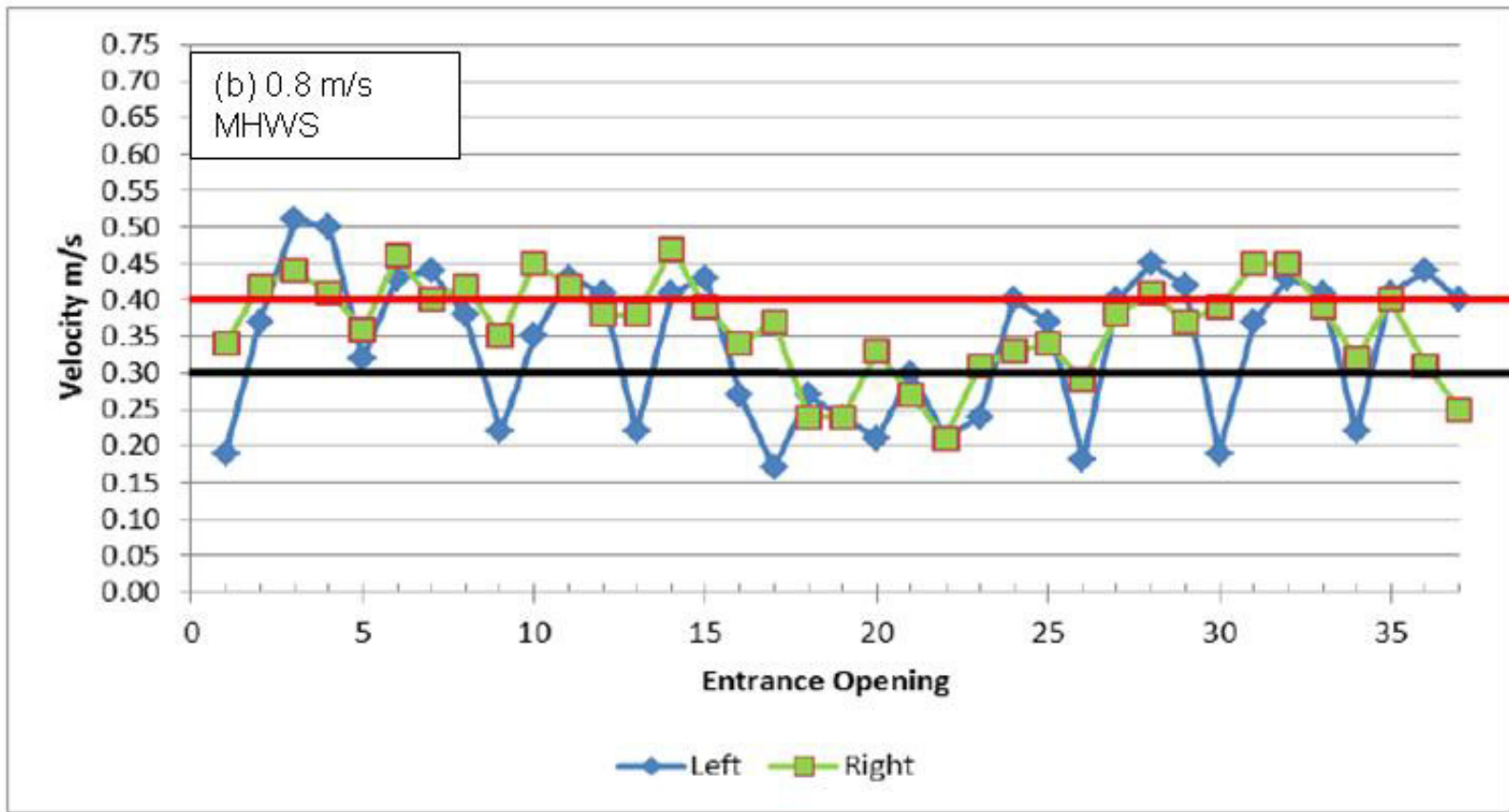

Figure A4 Escape velocities measured at points along the screen face in physical hydraulic model at 0.8 m s⁻¹ tidal flow (Ref [18])

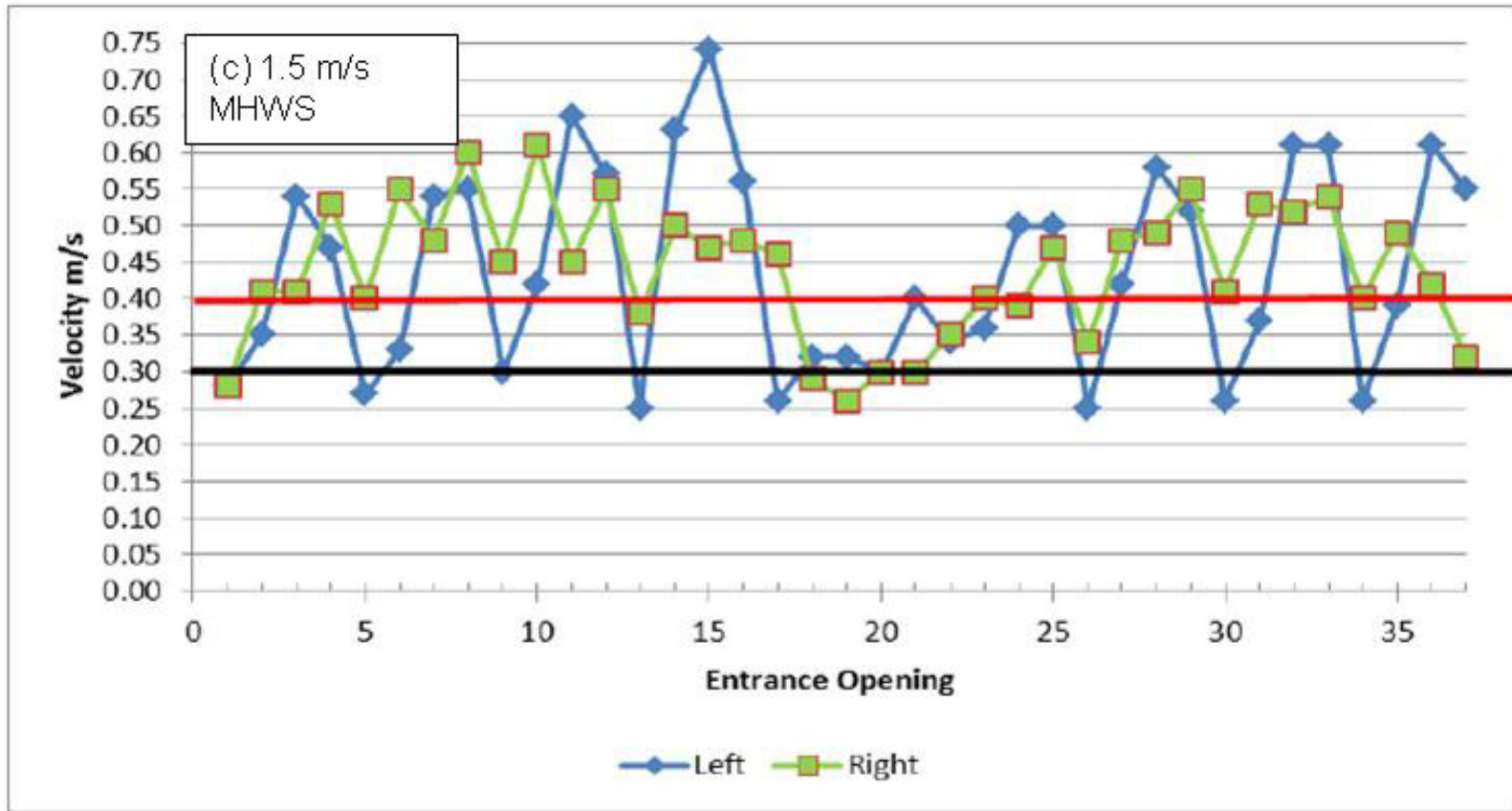

Figure A5 Escape velocities measured at points along the screen face in physical hydraulic model at 1.5 m s⁻¹ tidal flow (Ref [18])

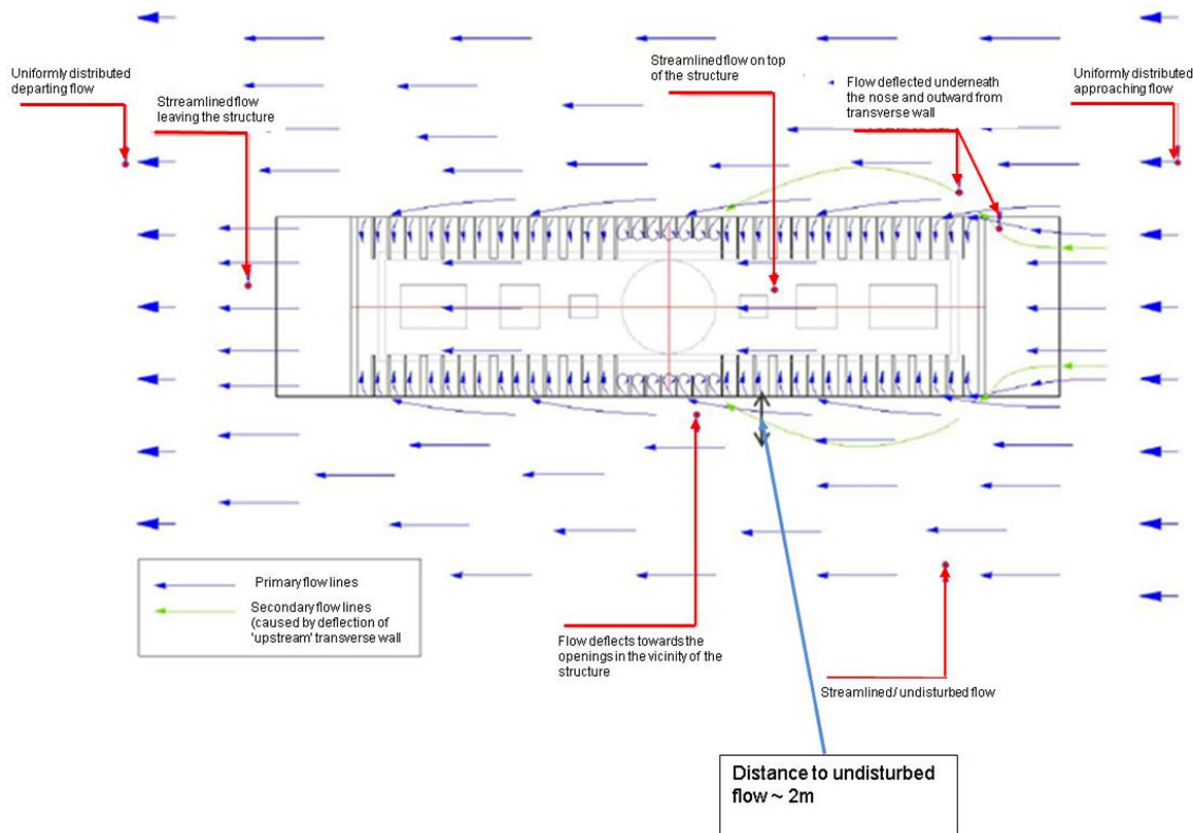
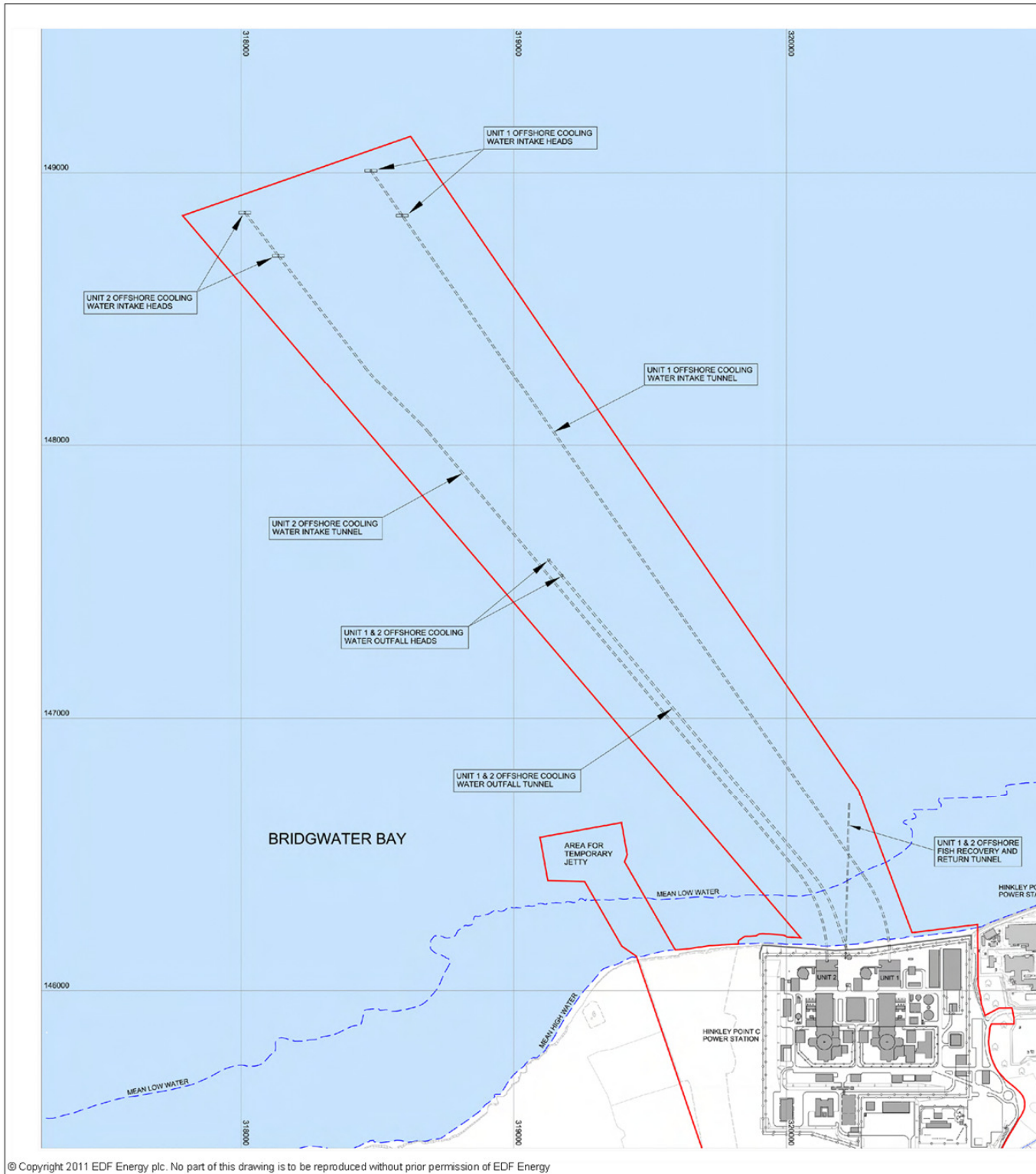

Figure A6: Flow pattern summary, showing narrow zone of hydraulic influence extending out to around 2 m from the intake face. This was similar for 0.8 m s^{-1} and 1.5 m s^{-1} cases.

APPENDIX B:

MAPS AT A3



© Copyright 2011 EDF Energy plc. No part of this drawing is to be reproduced without prior permission of EDF Energy

Figure B1: Intake, outfall and fish recovery and return (FRR) system tunnel alignments and head locations

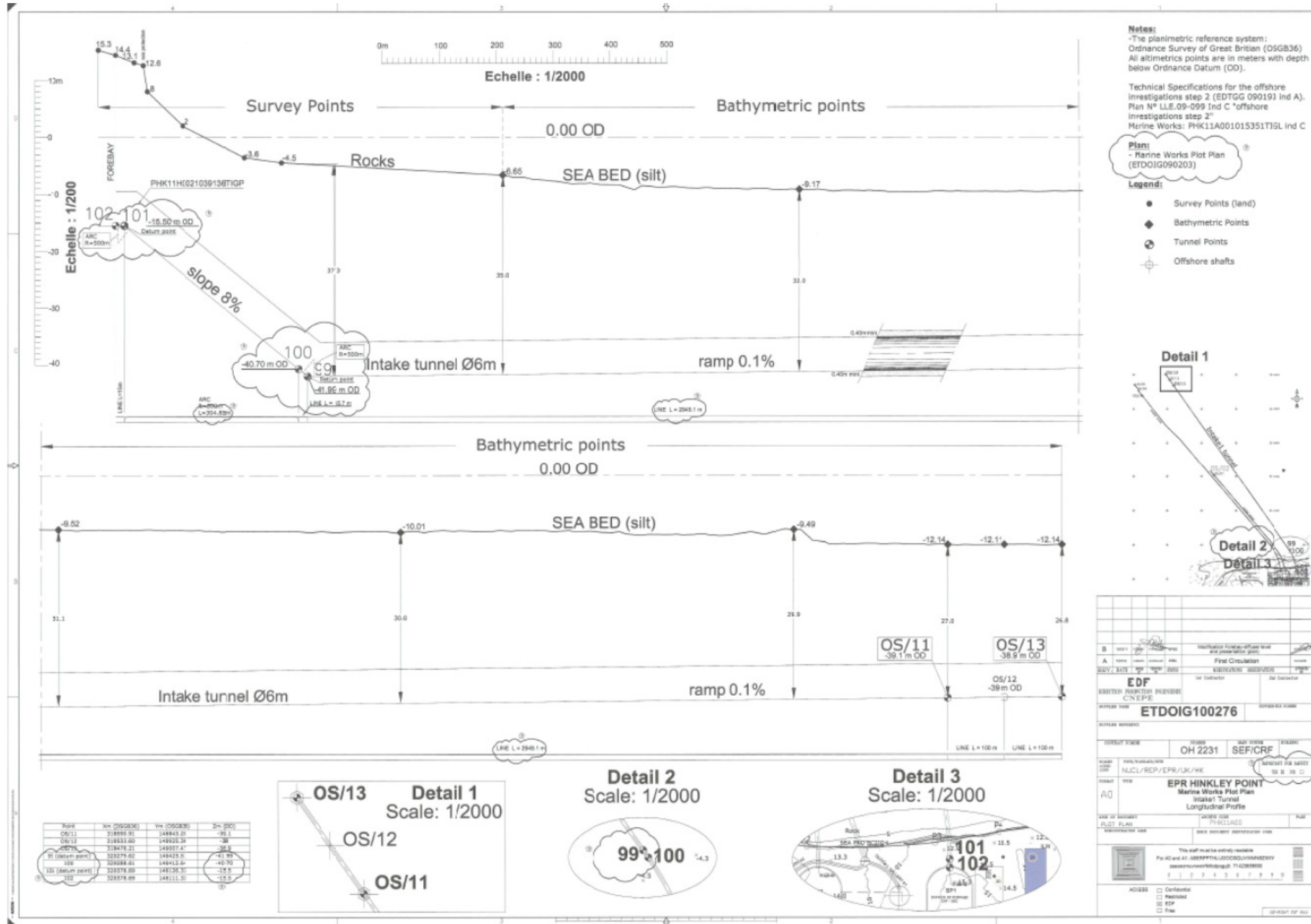

Figure: B2: Vertical profile of intake tunnel for unit 1

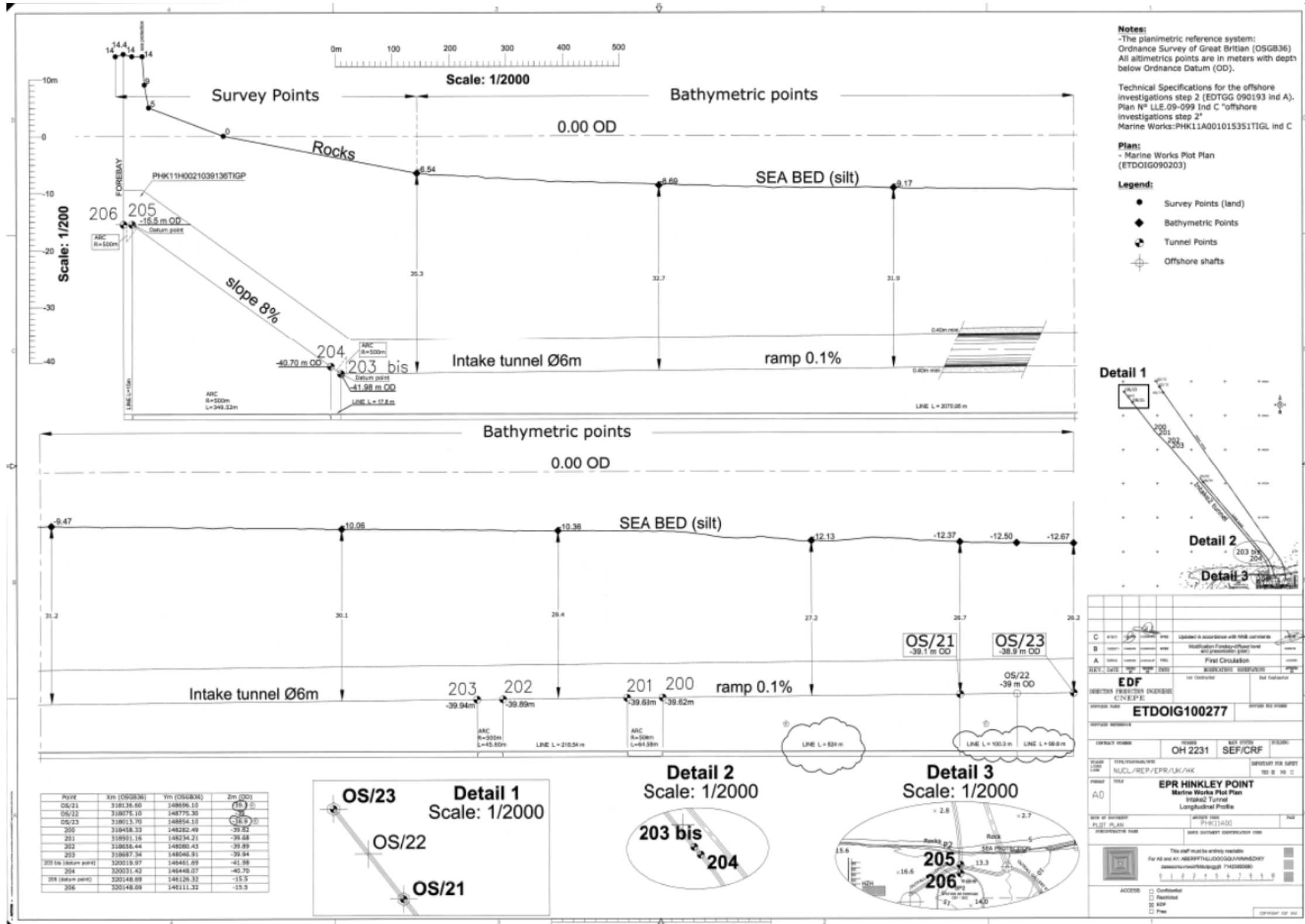

Figure B3: Vertical profile of intake tunnel for unit 2

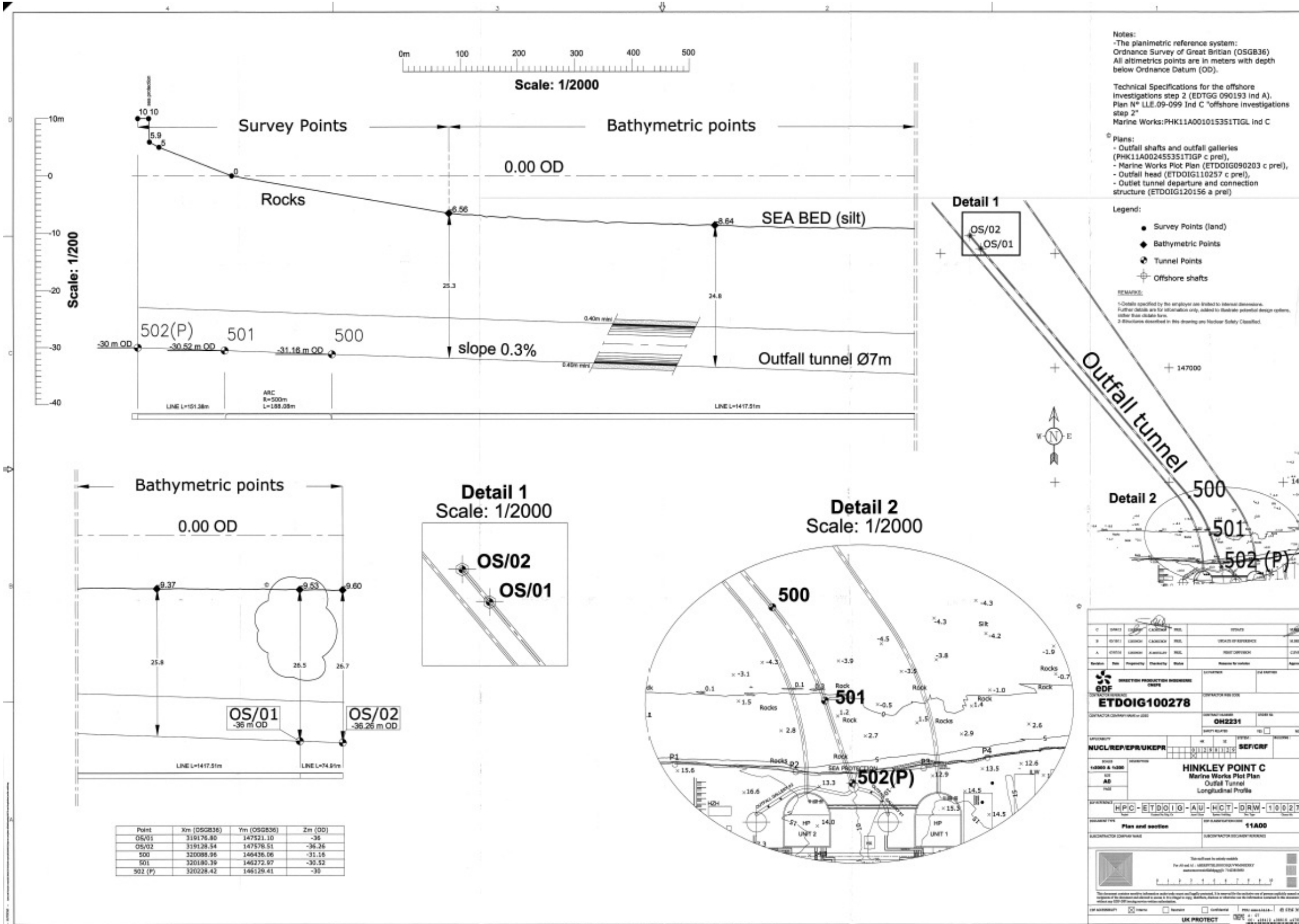

Figure B3: Vertical profile of outfall

APPENDIX C:

SELECTED 3-DIMENSIONAL IMAGES OF THE FOREBAY (HPF) AND COOLING WATER PUMP HOUSE (HP)

Note: The 3-dimensional model is currently only available for these elements. The filtering debris recovery pit (HCB), and fish return system (HCF) is not yet available.

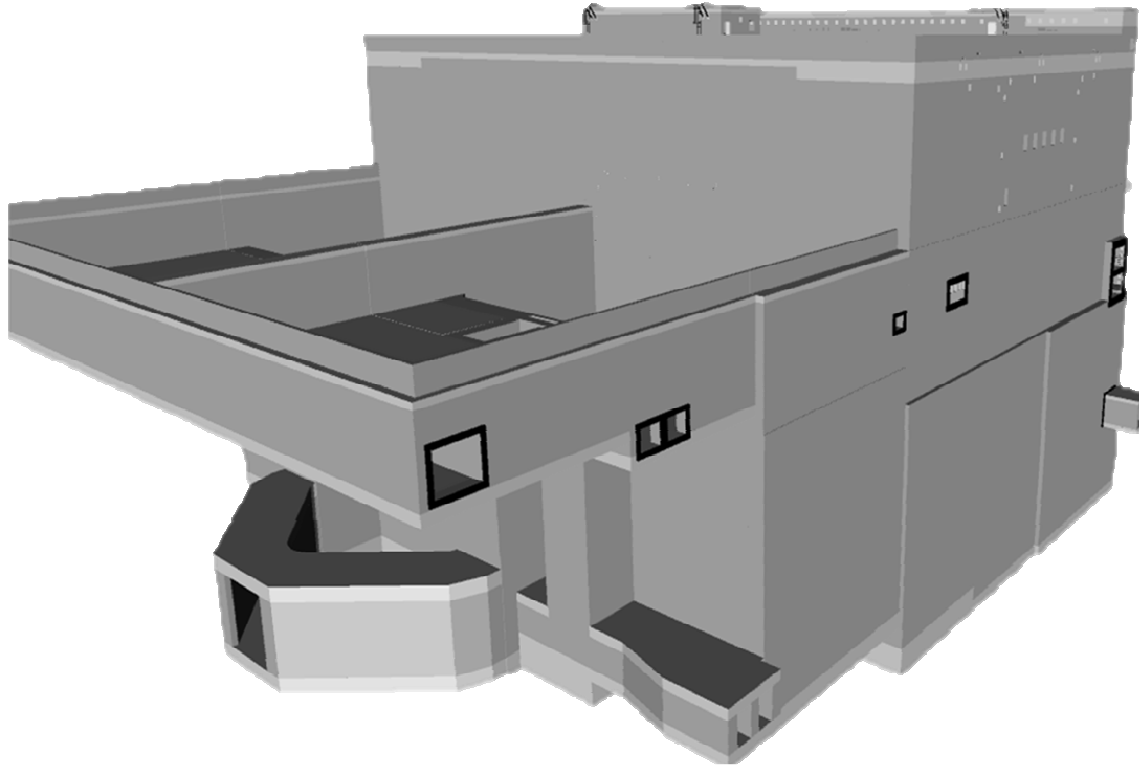

Figure: C1: Intake tunnel arriving at forebay (HPF). View of forebay (HPF) and cooling water pump house (HP) looking landward

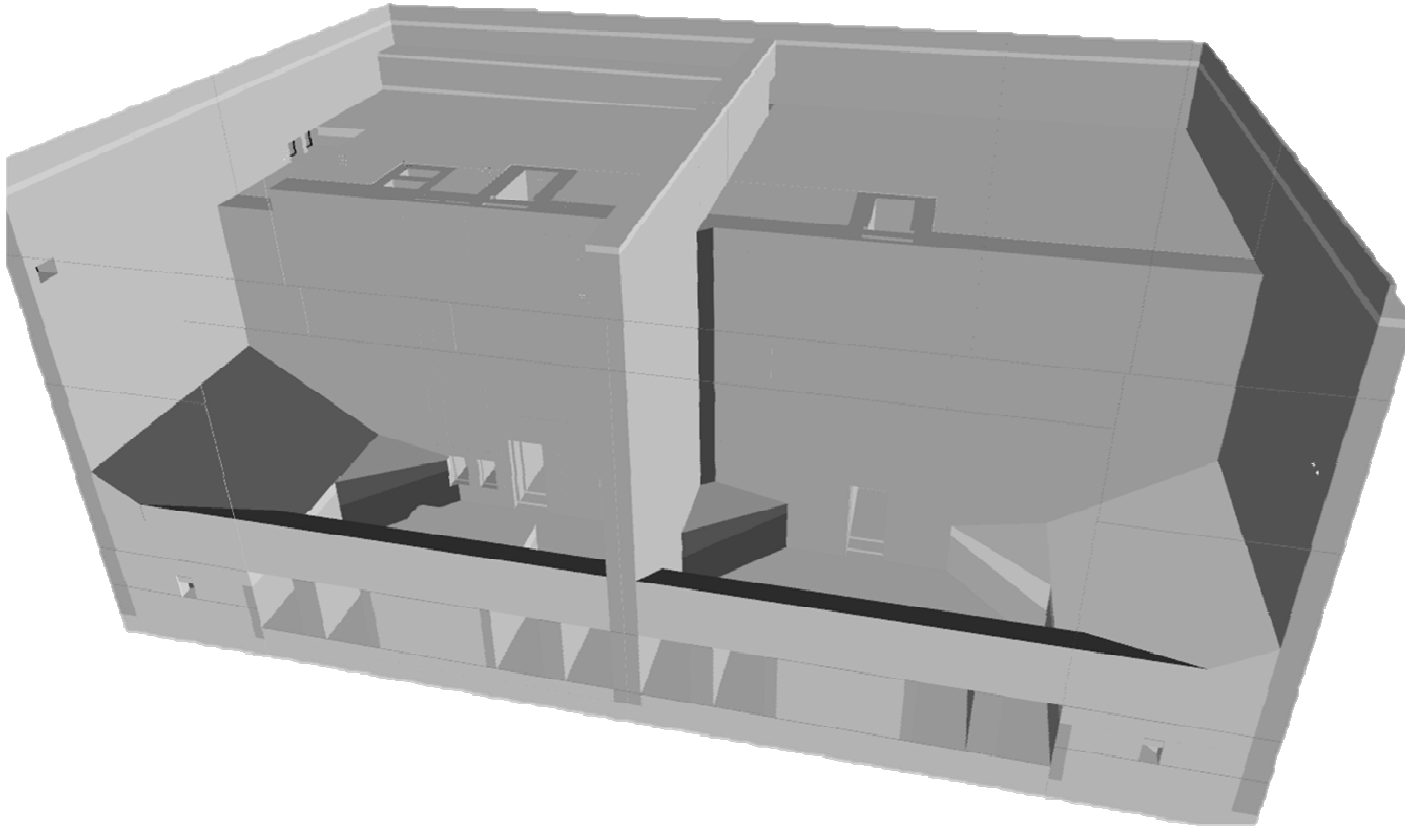

Figure: C2: Section through Forebay (HPF) looking seaward.

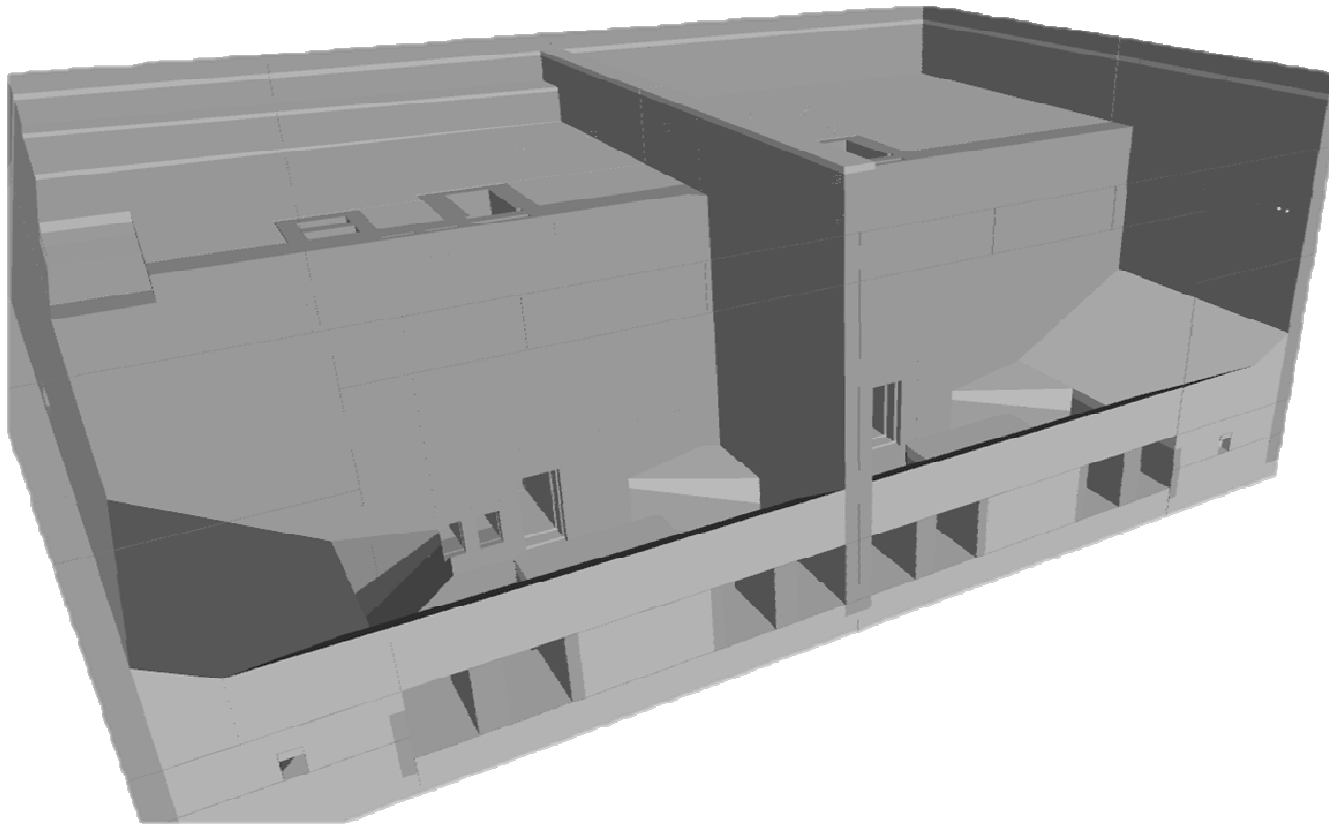

Figure: C3: Section through Forebay (HPF) looking seaward.

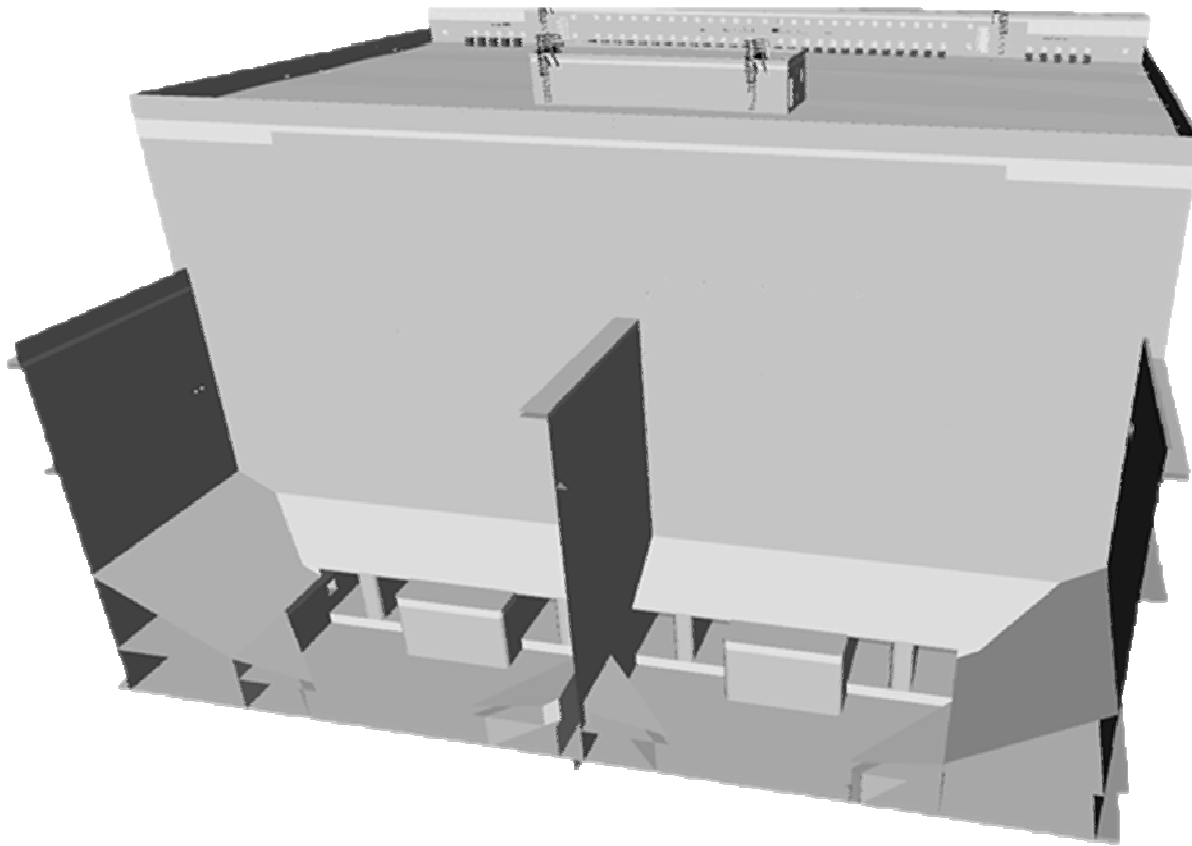

Figure: C4: Section through Forebay (HPF) looking landward.

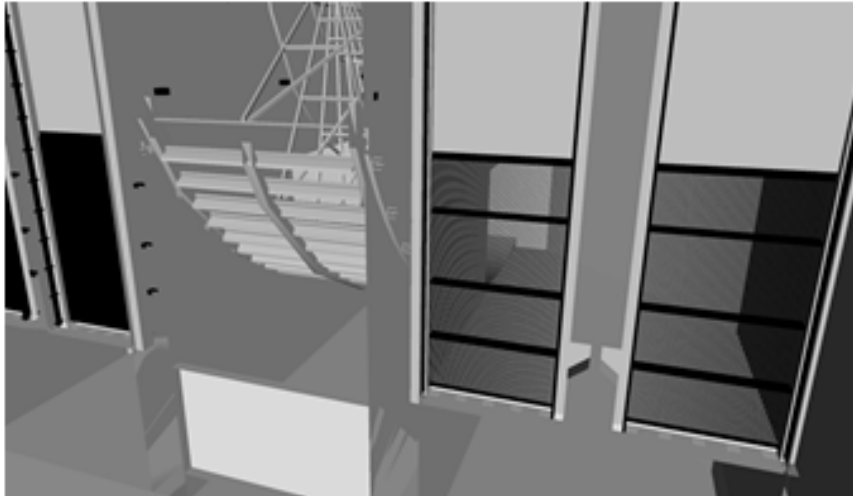

Figure: C5: Detail of train 3 entering drum screen well through coarse rack (SEF).

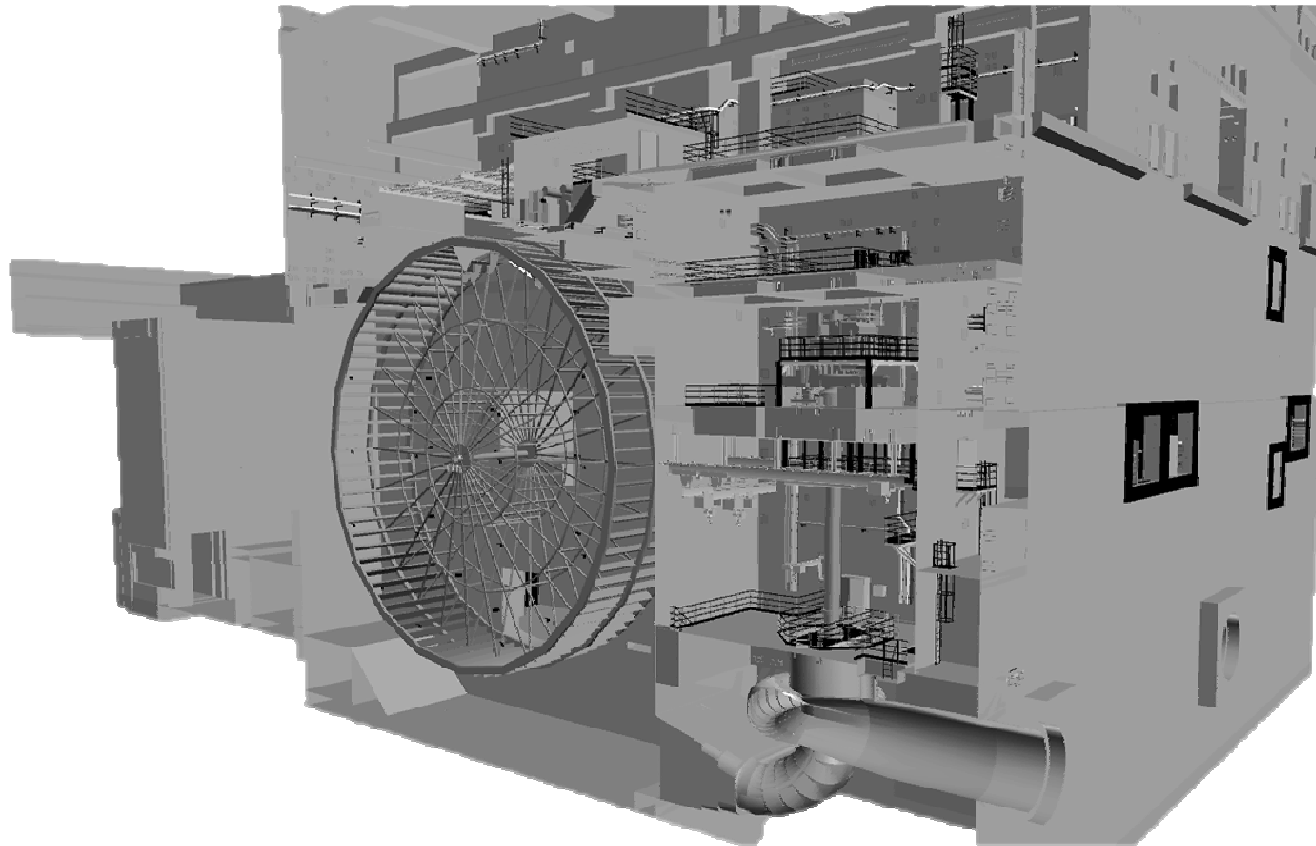

Figure: C6: Section through whole cooling water pump house (HP).

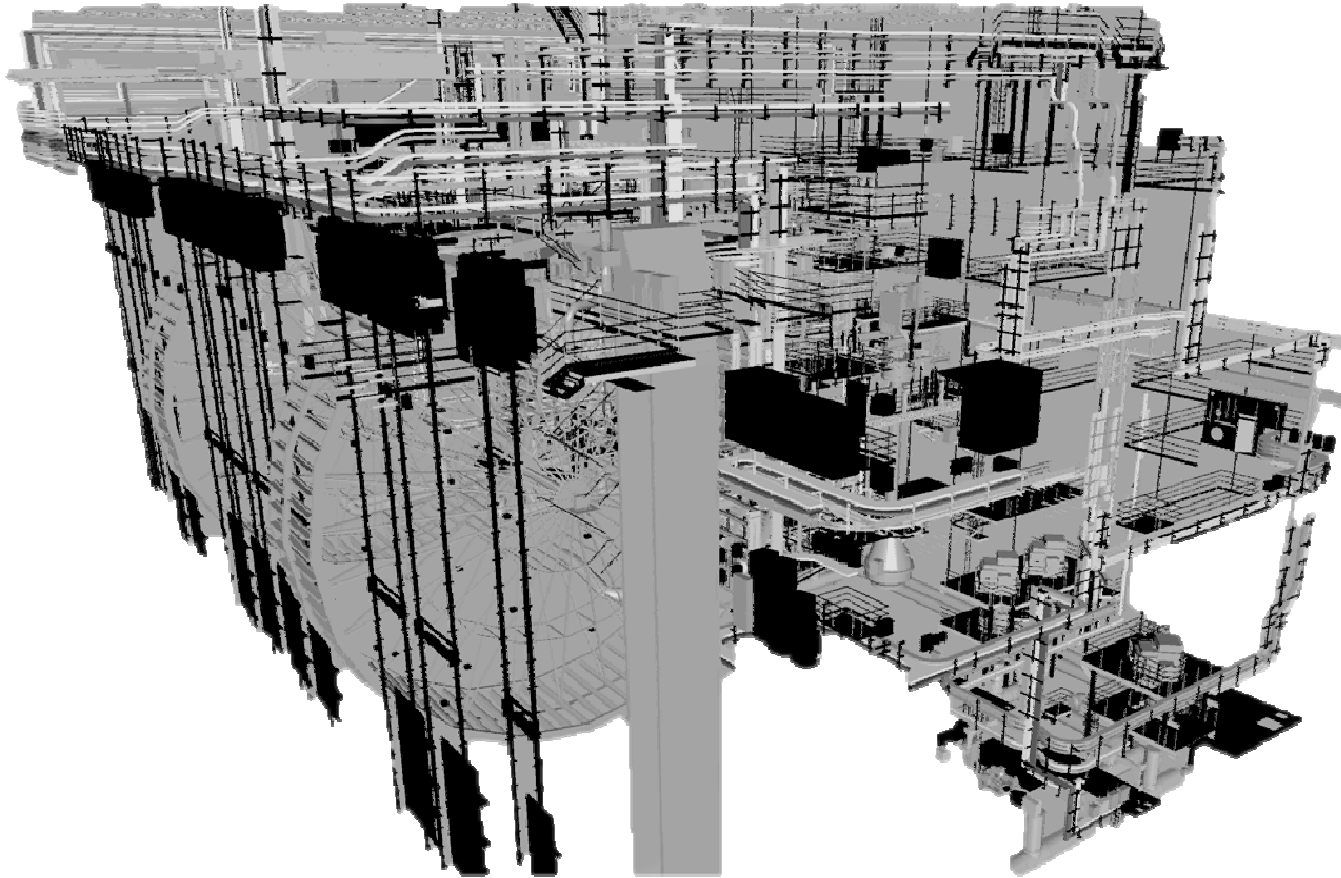

Figure: C7: Section through whole cooling water pump house (HP) showing coarse racks (SEF), band screens (CFI) and drum screens (CFI).

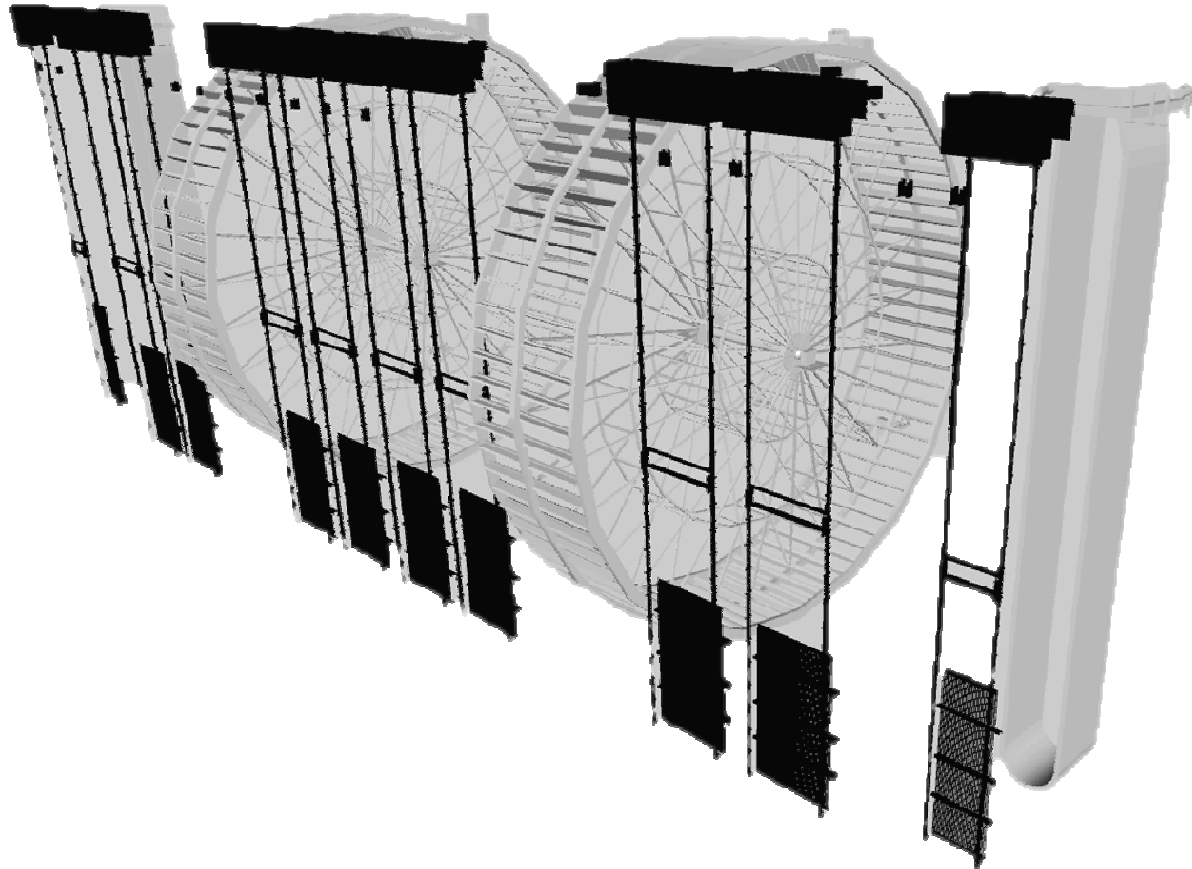

Figure: C8: Section through whole cooling water pump house (HP) showing coarse racks (SEF), band screens (CFI) and drum screens (CFI).

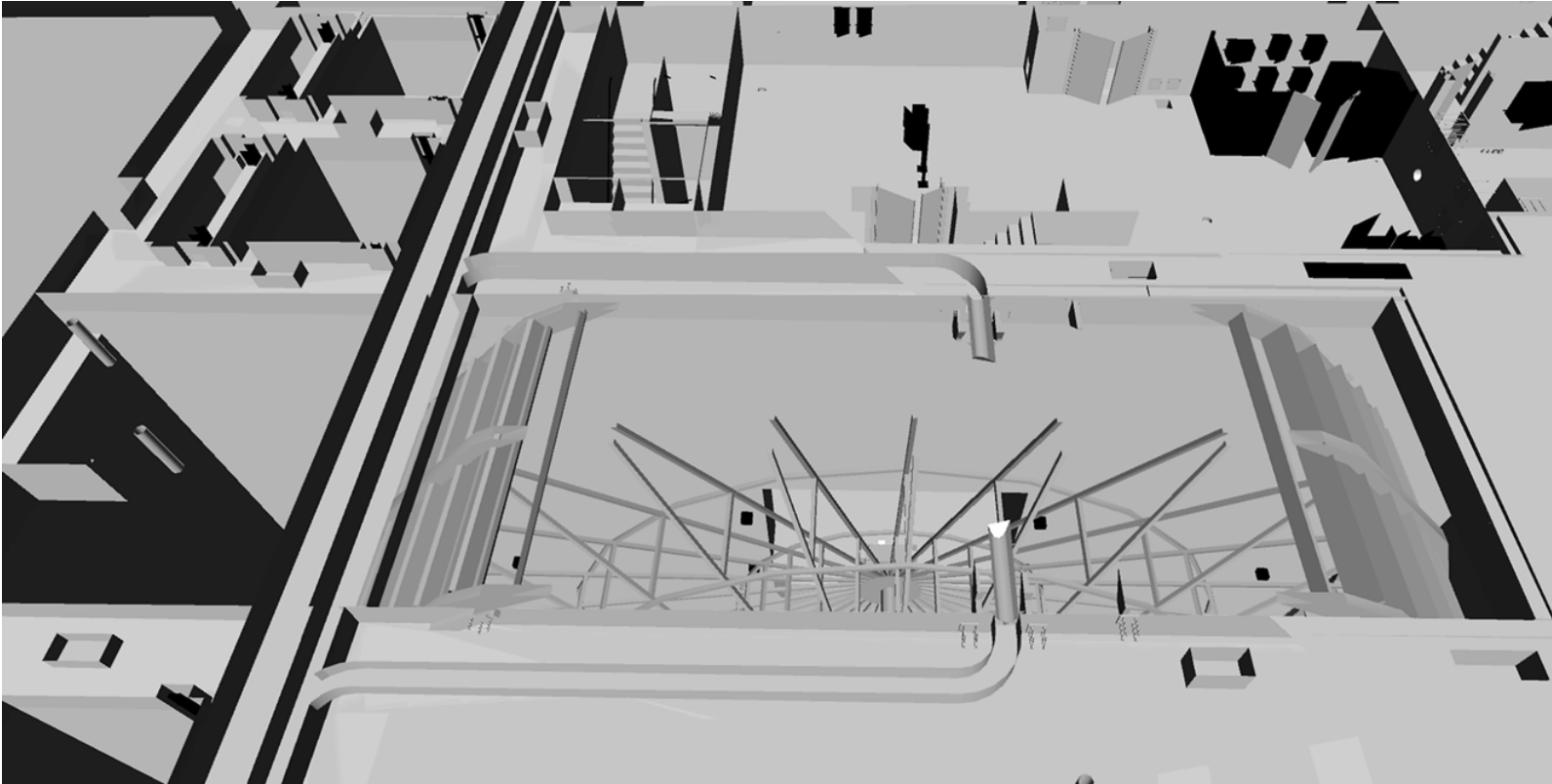

Figure: C9: detail of top of drum screen with fish collection gutters.

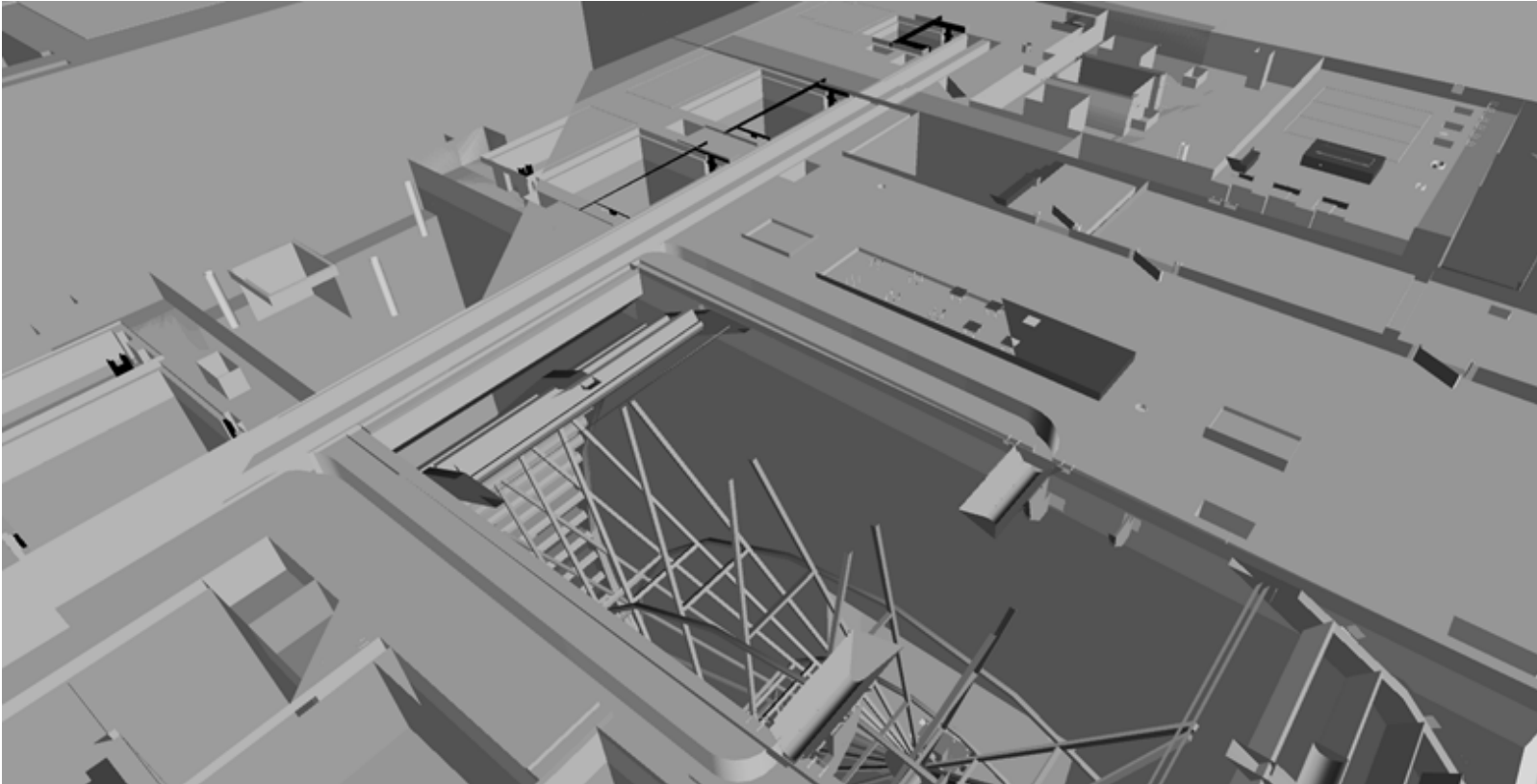

Figure: C10: detail of top of drum screen with fish collection gutters (eastern end, Trains 1 and 2). Flow is to west (to the left).

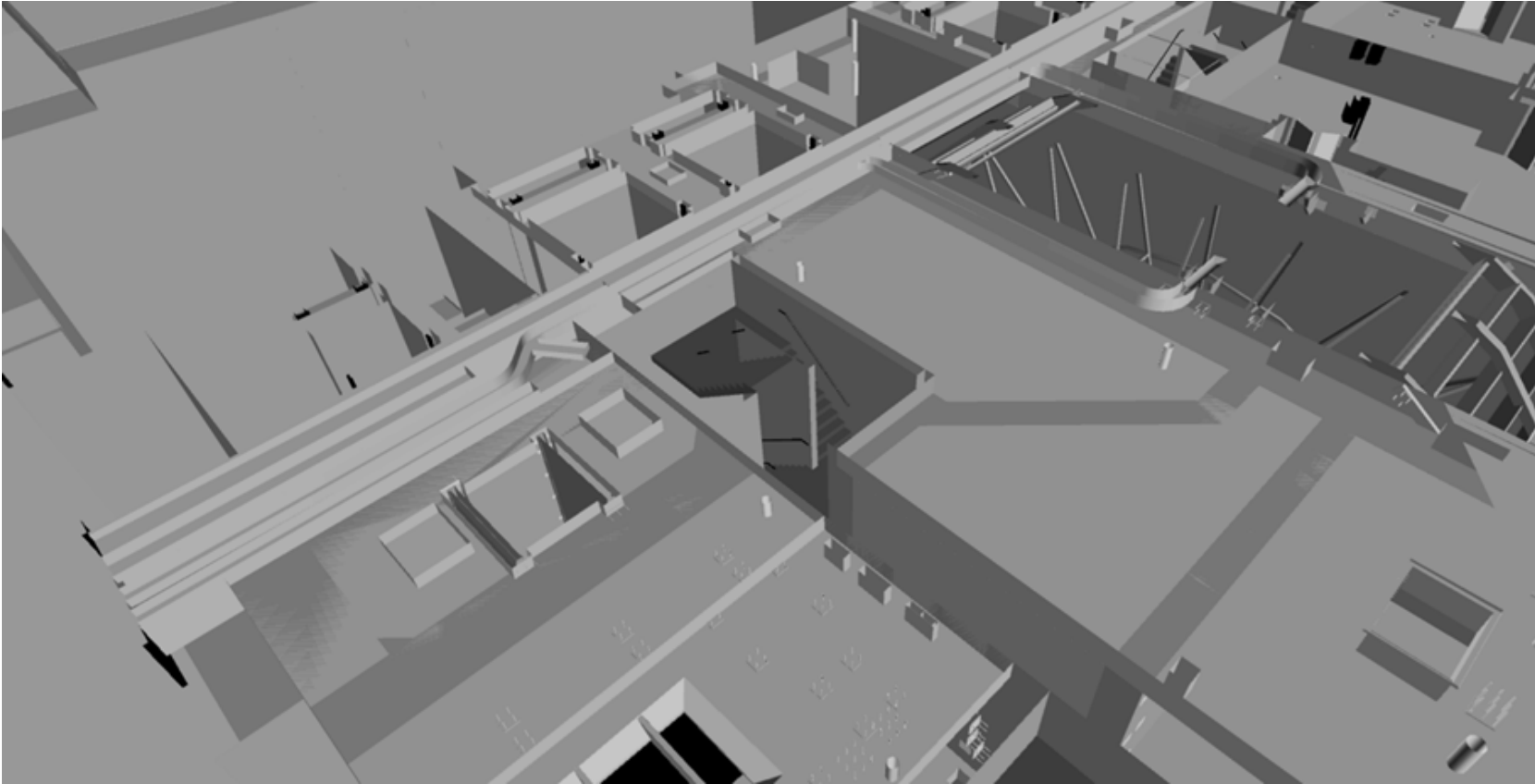

Figure: C11: detail of top of drum screen with fish collection gutters (western end, Trains 3 and 4). Flow is to west (to the left).