



Dairy Crest Ltd.

---

# DAVIDSTOW DAIRY

Environmental Permit Variation - Noise  
Assessment





Dairy Crest Ltd.

---

# DAVIDSTOW DAIRY

## Environmental Permit Variation - Noise Assessment

TYPE OF DOCUMENT (VERSION) CONFIDENTIAL

PROJECT NO. 70053935

DATE: APRIL 2022

[REDACTED]  
[REDACTED]  
[REDACTED]  
[REDACTED]  
[REDACTED]

WSP.com

---



# QUALITY CONTROL

---

Issue/revision	First issue	Revision 1
Remarks	Final Draft	Final Report
Date	29 April 2022	12 May 2022
Prepared by	[REDACTED]	[REDACTED]
Signature		
Checked by	[REDACTED]	[REDACTED]
Signature		
Authorised by	[REDACTED]	[REDACTED]
Signature		
Project number	70053935	70053935
Report number	70053935-Ac-001	70053935-Ac-001
File reference	[REDACTED] [REDACTED] [REDACTED] [REDACTED]	[REDACTED] [REDACTED] [REDACTED] [REDACTED]

# CONTENTS

---

<b>1</b>	<b>INTRODUCTION</b>	<b>1</b>
1.1	SUMMARY	1
<b>2</b>	<b>SITE DESCRIPTION</b>	<b>4</b>
2.1	SITE LOCATION	4
	SUMMARY	4
	NOISE SENSITIVE RECEPTORS	4
2.2	PROPOSED DEVELOPMENT AND ASSESSMENT SCOPE	6
<b>3</b>	<b>ASSESSMENT GUIDANCE</b>	<b>12</b>
3.1	BS4142: 2014: METHODS FOR RATING AND ASSESSING INDUSTRIAL AND COMMERCIAL SOUND (BS 4142)	12
3.2	NOISE AND VIBRATION MANAGEMENT: ENVIRONMENTAL PERMITS (23 JULY 2021)	13
3.3	NOISE IMPACT ASSESSMENTS INVOLVING CALCULATIONS OR MODELLING: INFORMATION YOU MUST SUBMIT TO THE ENVIRONMENT AGENCY IN A NOISE IMPACT ASSESSMENT THAT USES COMPUTER MODELLING OR SPREADSHEET CALCULATION	16
<b>4</b>	<b>BASELINE NOISE SURVEYS</b>	<b>20</b>
4.1	BACKGROUND NOISE SURVEYS	20
	BACKGROUND SOUND LEVELS	20
<b>5</b>	<b>SOURCE NOISE DATA</b>	<b>26</b>
5.1	CREAMERY	26
	HEPWORTH MEASUREMENT DATA	26
	MANUFACTURERS' DATA	28

---



<b>5.2</b>	<b>WATER PROCESSING FACILITY (WPF)</b>	<b>28</b>
	HEPWORTH MEASUREMENT DATA	28
	WSP SOURCE NOISE SURVEY	30
<b>6</b>	<b>NOISE MODEL AND PREDICTION RESULTS</b>	<b>33</b>
<hr/>		
<b>6.1</b>	<b>SUMMARY</b>	<b>33</b>
<b>6.2</b>	<b>APPROACH</b>	<b>33</b>
	TOPOGRAPHY, BUILDINGS, PLANS, RECEPTORS	33
	MODEL SETTINGS	33
<b>6.3</b>	<b>MODELLED SOURCES</b>	<b>34</b>
	CREMAERY	34
	WPF	38
<b>6.4</b>	<b>RECEPTOR NOISE LEVELS</b>	<b>43</b>
<b>7</b>	<b>ASSESSMENT</b>	<b>45</b>
<b>8</b>	<b>MITIGATION</b>	<b>47</b>
<b>9</b>	<b>CONCLUSIONS</b>	<b>48</b>
<hr/>		

---

## ***APPENDICES***

APPENDIX A

GLOSSARY OF ACOUSTIC TERMINOLOGY

APPENDIX B

FIGURES

APPENDIX C

MANUFACTURERS PLANT NOISE EMISSION DATA

APPENDIX D

NOISE CONTOUR PLOTS

APPENDIX E

LIMITATIONS



# 1 INTRODUCTION

---

## 1.1 SUMMARY

- 1.1.1. WSP has been appointed by Saputo Dairy UK to undertake an environmental noise assessment for submission to the Environment Agency as part of an application to vary to the existing Environmental Permit (reference EPR/BN6137IK/V009), issued 10 Nov 2020 covering operations at the Davidstow Dairy facility. The dairy is operated by Dairy Crest Limited (“Dairy Crest”). Saputo Dairy UK (SDUK, or ‘Saputo’) is a trading name used for Dairy Crest following its acquisition of the company in 2019. Dairy Crest remains the legal trading entity for the company and, therefore, it remains the named operator on the Environmental Permit.
- 1.1.2. The application to vary the existing Permit is being made to cover a number of changes (some proposed and some completed) to increase cheese and galacto-oligosaccharide (GOS) production capacity as well as making improvements to the management of wastewater at the site. The existing facility comprises a creamery with an associated, but geographically separate, water processing facility (WPF).
- 1.1.3. Guidance on the arrangements for dealing with noise ‘emissions’ under the Environmental Permitting regime is given in the following Environment Agency online guidance documents:
- *‘Noise and vibration management: Environmental Permits. How UK environment agencies assess noise, legal requirements for managing noise, noise impact assessment and noise management plans. This replaces H3 guidance’*, the latest version of which is dated 31 January 2022; and
  - *‘Noise impact assessments involving calculations or modelling: Information you must submit to the Environment Agency in a noise impact assessment that uses computer modelling or spreadsheet calculation’*, the latest version of which is dated 06 November 2019.
- 1.1.4. In line with the requirements of the above guidance, a predictive noise assessment has been undertaken, with reference to BS4142: 2014+A1: 2019: *Method for rating and assessing industrial and commercial sound* (BS4142).
- 1.1.5. Saputo have previously undertaken baseline noise survey work for both the creamery and the WPF, and continue to do so as part of an annual noise benchmarking exercise. This work has been extensive and has included both source noise measurements of existing operational plant items and the establishment of the prevailing noise environment at a sample of the closest noise sensitive receptors to both the creamery and the WPF.

- 1.1.6. This previous baseline and assessment work was undertaken by Hepworth Acoustics with the findings detailed within the following technical reports:
- Hepworth Acoustics report reference: P18-098-R01v2 dated October 2018 and entitled *Dairy Crest WWTP<sup>1</sup>, Davidstow 2018 Baseline Noise Assessment*. [Hepworth Report 1].
  - Hepworth Acoustics report reference: P18-389-R01v2 dated November 2018 and entitled *Proposed developments at Dairy Crest Creamery / WWTP<sup>1</sup>, Davidstow Noise Impact Assessment*. [Hepworth Report 2].
  - Hepworth Acoustics report reference: P20-150-R01v1 dated April 2020 and entitled *Dairy Crest WWTP<sup>1</sup> April 2020 Noise Assessment*. [Hepworth Report 3].
  - Hepworth Acoustics report reference: P21-155-R01v1 dated May 2021 and entitled *Davidstow WPF<sup>1</sup> April 2021 Noise Assessment*. [Hepworth Report 4].
- 1.1.7. The above reports have previously been submitted to the Environment Agency and include assessments of noise emissions from the facility in accordance with BS4142, identification of key noise sources and the identification of noise mitigation measures which were subsequently implemented.
- 1.1.8. In addition to the above, Hepworth Acoustics also undertook additional source noise measurements on the creamery and WPF at the time of work undertaken to inform Hepworth Report 3 and Hepworth Report 4. Those measurement data were obtained at the request of WSP to assist with this Permit variation application. The completed source noise measurements included plant items / noise sources that are comparable to some of those which from part of the changes at the site that fall under the proposed Permit variation.
- 1.1.9. Also to inform the noise assessment work, WSP undertook further source noise measurements at the WPF in 2022. The purpose of WSP's survey was to obtain source noise measurement data for plant associated with one of the completed changes (Downstream Tertiary Filters). The installation of the Downstream Tertiary Filters had not been completed at the time of the previous Hepworth site visits, and manufacturers' technical noise emission data was found not to be sufficient.
- 1.1.10. The results of these previous noise surveys, in addition to manufacturers' technical noise emission data (where available) have been used to inform the completed noise assessment.
- 1.1.11. The source noise measurement data, along with technical noise emission data for the proposed site changes, have been used to inform the prediction of operational noise levels for the proposed Permit Variation. The operational noise levels have been compared against those previously determined during the Hepworth noise benchmarking exercise, to identify whether they are would give rise to a change in noise emissions form the site (as assessed in accordance with BS4142 in the Hepworth reporting).
- 1.1.12. The scope of the operational noise level predictions has been determined from a review of the proposed site changes. Many of the changes to the site are minor additions to indoor processes, which do not have the potential to cause a significant change in noise levels at the closest noise

---

<sup>1</sup> Waste Water Treatment Plan (WWTP) now known as the Water Processing Facility (WPF) – These acronyms can be considered interchangeable for the purpose of this report.



sensitive receptors, and have therefore been scoped-out of this assessment. Those aspects of the proposals which do have the potential to give rise to a change in operational noise levels at the nearest noise sensitive receptors have been 'scoped-in' to the assessment. Additional detail can be found in **Section 2.2**.

- 1.1.13. For those aspects which have been scoped-in, a detailed noise model has been prepared to predict operational noise levels. Predictions have been undertaken for a sample of the closest noise-sensitive properties. The report also considers whether any of the assessed noise sources require mitigation in order to comply with the principles of Best Available Techniques (BAT), as defined in '*Best Available Techniques (BAT) Reference Document for the Food, Drink and Milk Industries*' (2015) which forms part of the Industrial Emissions Directive 2010/75/EU (Integrated Pollution Prevention and Control).
- 1.1.14. This report details the findings of the completed assessment including the detail expressly stated as required within the Environment Agency online guidance documents as referenced above.
- 1.1.15. This report is necessarily technical in nature so a glossary of acoustic terminology can be found in **Appendix A**.

## 2 SITE DESCRIPTION

### 2.1 SITE LOCATION

#### SUMMARY

- 2.1.1. The existing creamery is located approximately 1.25km south-west of the village of Davidstow and approximately 4km north-east of the town of Camelford, in the county of Cornwall.
- 2.1.2. The site is located east of the A39 Atlantic Highway (between Camelford in the south-west and Wainhouse Corner in the north-east), and south of the A395 which connects the A39 in the west with the villages of Davidstow, Hallworthy and more in the east. To the south, the creamery is bound by open farmland and the Davidstow Airfield and Cornwall at War Museum, whilst to the east the site is bound by Blacka Lane which connects the A395 in the north with the Davidstow Airfield in the south, and acts as the primary HGV access to the site.
- 2.1.3. Individual dwellings are present in all directions from the dairy, but at varying distances.
- 2.1.4. The associated WPF is located approximately 1km due east of the creamery and is connected via pipelines.
- 2.1.5. The WPF is surrounded on all sides by open farmland, but with individual dwellings located at moderate to substantial distances away.
- 2.1.6. The site boundary is presented in **Figure B1 of Appendix B**.

#### NOISE SENSITIVE RECEPTORS

- 2.1.7. A sample of the closest noise sensitive receptors, in all directions from the creamery and WPF, have been selected for assessment. These are also presented on **Figure B1 of Appendix B**. All of these receptors are residential in nature so are considered to be of 'high' sensitivity to potential noise impacts.
- 2.1.8. These receptors are also tabulated in **Table 2-1** and **Table 2-2** below. The receptor numbering used is consistent with that adopted used within the Air Quality Assessment and receptors have been listed in clockwise order starting in the north.

**Table 2-1 – Closest Noise Sensitive Receptors to the Creamery**

Reference	Name	Description	Direction from Site Boundary	Distance from Site Boundary (m)	Ordnance Survey Grid Reference	
					X	Y
R25	Tresplatt Farm, Davidstow	Residential	North	195	213765.9	86971.5
R26	Wayside, Davidstow	Residential	North-east	25	213906.3	86832.7
R27	Victoria, Davidstow	Residential	North-east	15	213907.9	86819.6
R28	Moorcroft, Davidstow	Residential	North-east	15	213916.7	86796.8
R29	The Bungalow, Davidstow	Residential	North-east	29	213932.0	86781.9
R01	Treveth	Residential	North-east	65	213971.5	86774.7
R40	Nottles Park	Residential	South-east	25	213994.0	86405.3

R09	Fowey Bungalow	Residential	South-east	165	214005.1	86211.0
R10	Homeleigh	Residential	South-east	220	214041.3	86169.6
R42	St Kitts Farm	Residential	West	305	213406.0	86398.8
R21	Nettings Park, Davidstow	Residential	North-west	75	213643.0	86728.6

**Table 2-2 – Closest Noise Sensitive Receptors to the WPF**

Reference	Name	Description	Direction from Site Boundary	Distance from Site Boundary (m)	Ordnance Survey Grid Reference	
					X	Y
R38	Trewassa Flats	Residential	North	335	214531.8	86784.5
R37	Rest Holme, Trewassa	Residential	North	330	214607.7	86844.2
R36	Manor Park, Trewassa	Residential	North	295	214660.2	86836.2
R03	Trehane House	Residential	North	585	214605.2	87139.1
R33	Wicketts Cottage, Trewassa	Residential	North	250	214670.9	86787.9
R32	Tremar Cottage, Trewassa	Residential	North	245	214687.2	86792.9
R31	Greenwold Cottage, Trewassa	Residential	North	200	214711.8	86757.5
R35	Lowertown, Trewassa	Residential	North	280	214748.4	86862.0
R34	Greenvalley Bungalow, Trewassa	Residential	North	220	214743.2	86797.8
R02	The Pines	Residential	North-east	675	215196.3	87228.6
R13	4 Lillipark	Residential	North-east	580	215367.9	86983.3
R14	Penmarrod	Residential	North-east	625	215447.7	86951.5
R06	Canapark	Residential	North-east	775	215629.0	86944
R04	Tremblary Cottage	Residential	North-east	1350	215991.3	87445.2
R07	45 Inny Vale	Residential	North-east	945	215827.6	86906.5
R08	Ivydene	Residential	East	975	215878.0	86825.4
R39	Treworra Barton	Residential	East	465	215395.4	86610.1
R12	Owls Gate, Treworra	Residential	East	455	215384.5	86524.2
R16	Oxencombe, Tremail	Residential	East	1235	216165.7	86525.2
R41	Old Firge Cottage	Residential	East	1270	216191.0	86469.9
R15	St. Lawrence, Tremail	Residential	East	1170	216079.8	86388.3
R05	Trewinnow Bungalow	Residential	East	1580	216456.4	86176.7
R17	Bell View, Davidstow	Residential	East	1060	215937.7	86271.9
R18	Hendawle Farm	Residential	South-east	975	215773.8	86086.2
R19	Higher Tremail Farm	Residential	South-east	1140	215695.5	85724.1
R20	Butterwell, Davidstow	Residential	South	825	215198.3	85734.6

R11	Barn Park Bungalow	Residential	South-west	780	214128.5	86059.9
R30	Barnpark Farm, Davidstow	Residential	West	395	214425.5	86308.9
R24	Newhouse, Davidstow	Residential	North-west	700	214139.4	86861.8
R23	Moor View Farm, Davidstow	Residential	North-west	710	214151.1	86906.1
R22	Rose Tree Cottage, Davistow	Residential	North-west	640	214271.3	86951.4

## 2.2 PROPOSED DEVELOPMENT AND ASSESSMENT SCOPE

- 2.2.1. The changes to the facility are to increase cheese and GOS production capacity and improve the management of wastewater at the site. This will be achieved by the implementation of six projects at the creamery and a series of changes to the WPF. Some of the projects / changes have been completed whilst others remain proposed.
- 2.2.2. The six creamery projects are described in **Table 2-3**, whilst **Table 2-4** lists the WPF changes. These tables also list whether the projects / changes are ‘scoped-in’, or ‘scoped-out’ of this assessment, including the evidence base for the decision made.
- 2.2.3. In addition to the six projects, a Solar farm is proposed at the site, but this is not a prescribed activity under the EPR and so has been scoped-out of this assessment. Regardless, Solar farms are typically very quiet in nature.

**Table 2-3 –Summary of Development Proposals (Six Projects)**

Project	Summary Description	Scoped-In / Scoped-Out
Project No. 1 Cleaning-in-place (CIP) 4-hour Turnaround	A new CIP set will provide additional cleaning channels to shorten the length of time taken to clean the cheese department. This will shorten CIP cleans by 2 hours each time (from 6 to 4 hours), thereby increasing the available production time and capacity (20-hr processing).	The new CIP will be located entirely within the existing building structure and is small in comparison to other existing operations and processes in its vicinity.  The proposed location of this project is on the western side of the facility, removed from local receptors.  This project is considered unlikely to cause any significant change in operational noise level at the closest existing receptors and has therefore been <b>scoped-out</b> of the assessment.
Project No. 2 Milk Protein Standardisation	A small portion (approximately 20 %) of the raw milk will be concentrated via a new ultra-filtration (UF) membrane to increase fat, protein and milk solids. This protein standardised milk will be dosed back into the main raw milk stream thus increasing the cheese milk protein by approximately 9 %. This increases the curd yield from each vat and ultimately the hourly cheese production capacity (t/hr) by	The new UF plant will be located entirely within the existing building structure and is small in comparison to other existing operations and processes in its vicinity.  The proposed location of this project is at the northern corner of the facility, removed from local receptors.  This project is considered unlikely to cause any significant change in operational noise level at the closest

	<p>~9 %. Following the implementation of Project No. 6 below, this process change will increase the curd production from 10.5 t/hr to 11.4 t/hr.</p> <p>It is intended to either UV treat the permeate from this process and reintroduce it back into the whey system for conversion into demineralised whey powder or concentrate it via reverse osmosis (RO) for export off site as a functional ingredient.</p>	<p>existing receptors and has therefore been <b>scoped-out</b> of the assessment.</p> <p>However, the development may require two additional external silos in the future. If required these would be located adjacent to the existing raw milk silos and would have low level agitators akin to the existing silos. These elements (silos + agitators) have therefore been <b>scoped-in</b> to the assessment work, in case they are required in the future.</p>
<p>Project No. 3 Milk Fat Standardisation</p>	<p>Reduced fat cheese is manufactured in a batch process and currently limited by the volume of skimmed milk that can be separated and stored. The new processing solution allows skimmed milk to be separated and blended in-line in a continuous process. This saves time and therefore allows for an increase in production capacity.</p>	<p>Two new milk separators will be located entirely within the existing building structure and are small in comparison to other existing operations and processes in their vicinity.</p> <p>The proposed location of this project is on the western side of the facility, removed from local receptors.</p> <p>This project is considered unlikely to cause any significant change in operational noise level at the closest existing receptors and has therefore been <b>scoped-out</b> of the assessment.</p> <p>However, the development may require two replacement cream silos and a new freezer building in the future.</p> <p>If required, the two new 60,000l cream silos would replace two existing 30,000l cream silos. They would have top entry mixers akin to the existing cream silos.</p> <p>If required, the freezer building would be located on the western side of the existing installation building and would contain chest freezers so no external refrigeration plant would be required.</p> <p>These elements (silos + top entry mixers and freezer building) have therefore been <b>scoped-in</b> to the assessment work, in case they are required in the future.</p>

<p>Project No. 4 Whey Protein Concentrate (WPC35)</p>	<p>Up to 10 % of the separated sweet whey stream is treated via a UF plant to concentrate the protein content. The concentrated whey is dosed back into the main whey stream to standardise the protein content of the demineralised feed stream. The permeate from the UF plant is then passed through a RO plant to concentrate the solids (from 13 % to 20 %) prior to export from site. The permeate from the RO plant is currently discharged to the WPF but it is proposed to recycle this water stream to use for cleaning purposes.</p>	<p>The new plant for this project will be located entirely within the existing building structure towards the centre of the installation, in an area without any external walls, and well removed from local receptors.</p> <p>This project is considered unlikely to cause any significant change in operational noise level at the closest existing receptors and has therefore been <b>scoped-out</b> of the assessment.</p>
<p>Project No. 5 GOS Bulk Loading</p>	<p>An alternative method of transporting GOS product to customers has been implemented on site. The solution enables the export of bulk tanker volumes of up to 29,000 kg instead of individual 1,000 kg IBCs. This project incorporates an additional export storage tank, process pipework, new tanker loading bay and a tanker Cleaning In Place (CIP) set.</p>	<p>The new tank for this project would be located entirely within the existing building structure in the south-central area, a position without any external walls, and therefore well removed from local receptors. The tank itself is also not expected to be a noise generative source and so has been <b>scoped-out</b> of the assessment.</p> <p>However, the development also includes a new (completed) tanker loading bay with roller shutter doors to both ends, located on the south side of the existing installation building. There is a newly installed, containerised CIP set located outside the new loading bay on its southern side.</p> <p>These elements have therefore been <b>scoped-in</b> to the assessment work, because their use has the potential to generate noise and there is a receptor to the south-east at a distance of approximately 165m.</p>
<p>Project No. 6 Cheese Capacity Growth Phase 3</p>	<p>It is proposed to implement a number of process changes that will increase the curd production capacity from 9.6 t/hr to 10.5 t/hr. Only one additional cheese vat (no. 12) will be installed, however, the ancillary plant and equipment will enable the vats to be filled and emptied quicker, increasing the processing capacity from 87,000 l/hr to 95,000 l/hr. The ancillary plant and equipment will include a larger milk pasteuriser with more plates, an additional curd pump and whey separator and a new Rapid Chill Store (RCS).</p>	<p>The new plant for this project will all be located entirely within the existing building, in the existing cheese production facility which is towards the north-eastern part of the installation building, in an area without any external walls and well removed from local receptors.</p> <p>This project is considered unlikely to cause any significant change in operational noise level at the closest existing receptors and has therefore been <b>scoped-out</b> of the assessment.</p>

**Table 2-4 – Davidstow WPF Redevelopment – Changes on Site**

<b>Change / Improvement</b>	<b>Development Progress</b>	<b>Scoped-In / Scoped-Out</b>
Contingency lagoon & Odour Control Unit (OCU)	Installed and operational	The new 600m <sup>3</sup> Contingency Lagoon is not noise generative and has been <b>scoped-out</b> . The associated Odour Control Unit (OCU) has the potential to be noise generating and is therefore <b>scoped-in</b> .
Two new Dissolved Air Floatation units (DAFs)	Installed and operational	<b>Scoped-in</b> .
Covering / extraction from Balancing Tank 1 (BT1) and divert tanks & OCU	Installed and operational	Balance tank 1 (BT1) and the divert tanks are now covered. They are not noise generating and have been <b>scoped-out</b> . The associated OCU has the potential to be noise generating and is therefore <b>scoped-in</b> .
Upgraded Activated Filter Membrane (AFM) filtration tanks	Installed and operational	The upgraded AFM filtration tanks are not noise generative and have been <b>scoped-out</b> .
3 <sup>rd</sup> Reverse Osmosis (RO) plant	Installed and operational	The RO process is not noise generative and has been <b>scoped-out</b> .
UF / RO overflow attenuation tank	Installed and operational	This attenuation tank is not noise generative and is therefore <b>scoped-out</b> .
Downstream tertiary filters	Installed and operational	This change comprises three tertiary filters, with outfall into a filtrate tank connected to two pairs of transfer pumps (each pair operated on a duty / stand-by basis). These elements have been <b>scoped-in</b> .
4 <sup>th</sup> Membrane Bioreactor (MBR) loop	Installed and operational	The 4 <sup>th</sup> MBR loop will be housed inside the existing building housing DAF 1 and is not expected to make an appreciable difference to the noise break-out and has therefore been <b>scoped-out</b> .
New raw material store	Installed and operational	This store is used to house Intermediate Bulk Containers (IBCs) and is not noise generating and has been <b>scoped-out</b> .
Upgraded outfall pipework from WPF	Installed and operational	This pipework is not considered noisy and has been <b>scoped-out</b> .

New aeration pumps for BT1	Installed and operational	BT1 itself is not noise generating. However, the four Landia pumps, located at roughly 12, 3, 6 and 9 o'clock are. These pumps have therefore been <b>scoped-in</b> .
Installation of acoustic fencing	Installed	Not noise generative and has therefore been <b>scoped-out</b> . However, the noise attenuation benefit from the installed acoustic fence has been accounted for in the noise level predictions.
Noise monitoring equipment	Installed and operational	Not noise generative and has therefore been <b>scoped-out</b> .
Floating discs on BT1 and anoxic pits 2 and 3	Installed and operational	The floating discs are not noise generating and are <b>scoped-out</b> .
Perimeter containment wall	Installed	Not noise generative and has therefore been <b>scoped-out</b> . However, the noise attenuation benefit from the installed containment wall has been accounted for in the noise level predictions.
Replacement of W2 v notch sampling point with a monitoring emissions to air, land and water (MCERTS) flume	Proposed	The processes involved in this development are not considered noisy and have been <b>scoped-out</b> .
Enclosure of sludge centrifuges and trailer	Proposed	Not noise generative and has therefore been <b>scoped-out</b> .
Installation of an automated forward / divert solution for both cheese/whey and Demin/GOS	Proposed	The processes involved in this development are not considered noisy and have been <b>scoped-out</b> .

2.2.4. In addition to the contents of **Table 2-4**, once completed, the proposed developments will give rise to a small increase in HGV movements to / from the creamery site. Prior to the projects detailed in **Table 2-4** there are typically 50 to 60 HGV movements to/from the site each day, with that due to increase by about 12 movements per day. The typical HGV movement numbers will therefore remain around 2 to 3 HGVs per hour.

2.2.5. Each incoming milk delivery takes around 5 minutes to circulate the internal site road and about 40 minutes to off-load at the intake bays on the north side of the creamery site. There are a total of seven intake bays, but only three tankers can currently be off-loaded at any one time. This would





remain unchanged by the projects detailed **Table 2-4**. Noise from the small increase in associated HGV movements has therefore been **scoped-out** of this assessment.

- 2.2.6. There would be no additional HGV movements to / from the WPF, so this has also been **scoped-out** of the assessment.

## 3 ASSESSMENT GUIDANCE

---

### 3.1 BS4142: 2014: METHODS FOR RATING AND ASSESSING INDUSTRIAL AND COMMERCIAL SOUND (BS 4142)

- 3.1.1. BS 4142 describes methods for assessing sound of an industrial and/or commercial nature, including sound from fixed installations (such as mechanical and electrical plant).
- 3.1.2. It provides a method of determining the 'rating level' for sources of industrial or commercial sound for the purposes of investigating noise impact, assessing sound from new, modified, or additional sources of sound, and assessing sound affecting new residential premises.
- 3.1.3. BS 4142 uses several specific terms to define the various levels used in assessments, including:
- Specific sound – the commercial / industrial noise source under consideration;
  - Residual sound – the sound level at the noise-sensitive receivers in the absence of the specific sound;
  - Ambient sound – the sound level at the noise-sensitive receivers in the presence of the specific sound (i.e. ambient = residual + specific);
  - Background level - the sound pressure level which is exceeded by the residual sound for 90% of the measurement period; and,
  - Rating level – the specific sound, corrected for acoustically distinguishing characteristics.
- 3.1.4. The basis of the assessment approach is to determine the Specific sound level of the source under assessment, as arising at the receptor/s being considered. Where the source contains acoustic characters, e.g. tonality, impulsivity or intermittency, corrections are added to the specific sound level in determination of the 'Rating level'. The Rating level is then compared against the Background sound level that is present in absence of the source under investigation. The difference between the two levels is an indication of the degree of impact associated with the source, although this is also context specific.
- 3.1.5. The Background sound level is determined by measurement for both the daytime and night-time periods, and detailed advice is provided on how to analyse the measurement data to identify representative values. Separate assessments are undertaken for both daytime and night-time periods.
- 3.1.6. With regards to acoustic character corrections, BS 4142 states that it is normally possible to carry out a subjective assessment of characteristics, based on the following correction guidelines:
- Tonality: +2 dB for a 'just perceptible' tone, +4 dB for 'clearly perceptible', and rising to +6 dB for 'highly perceptible' tones;
  - Impulsivity (rapidity of change and overall change in level): +3 dB for 'just perceptible' impulsivity, +6 dB for 'clearly perceptible', rising to +9 dB for 'highly perceptible' impulsivity; and,
  - Intermittency: if the on/off-time of the specific sound is readily distinctive at the noise-sensitive receivers, +3 dB.
- 3.1.7. Typically, the greater the difference between the background sound level and the rating level, the greater the magnitude of impact, although BS 4142 emphasises that this is highly context specific.
- 3.1.8. As a guideline, BS 4142 states that:

- A difference (between the background and rating level) of around +10 dB or more is likely to be indicative of significant adverse impact, depending on context
- A difference (between the background and rating level) of around +5 dB or more is likely to be indicative of adverse impact, depending on context
- The lower the rating level relative to the background level, the less likely it is that the specific sound will have an adverse impact, depending on context
- Where the rating level does not exceed the background level, this is an indication that the specific sound will have a low impact, depending on context.

3.1.9. However, BS4142 also requires careful consideration to context and states that the above scale is only an indication of likely impact and that the initial estimate may need to be modified to account for context.

3.1.10. The advice where there are low background sound levels / rating levels is that:

*“Where background sound levels and rating levels are low, absolute levels might be as, or more, relevant than the margin by which the rating level exceeds the background. This is especially true at night.”*

3.1.11. To provide numeric context to the above statement, the previous (1997) version of BS4142 described background noise levels of 30dB  $L_{A90,T}$  and rating levels of 35dB  $L_{Ar,Tr}$  as being ‘very low’.

3.1.12. This description is reasonable in the context that BS8233: 2014: *Guidance on sound insulation and noise reduction for buildings* and the World Health Organisation: *Guidelines for community noise* document detail noise criteria of 50 and 55dB(A)  $L_{Aeq,T}$  for external living areas such as residential gardens. Similarly, these documents detail criteria of 30 and 35 dB  $L_{Aeq,T}$  internally for sleeping / resting respectively, which are equivalent to 40 and 45dB(A) externally assuming a 10dB reduction through a partially open window to the inside.

3.1.13. Therefore, when background sound levels are around 30dB(A)  $L_{A90,T}$  or lower, it is considered that achieving a rating level of 35dB  $L_{Ar,Tr}$  corresponds to a ‘low impact’, regardless of the differential to the background sound level.

## **3.2 NOISE AND VIBRATION MANAGEMENT: ENVIRONMENTAL PERMITS (23 JULY 2021)**

3.2.1. This guidance was produced by the Environment Agency, the Scottish Environment Protection Agency (SEPA), Natural Resources Wales and the Northern Ireland Environment Agency in order to help those seeking environmental Permits, a variation to their Permit or to comply with their Permits.

3.2.2. The document was produced on 23 July 2021 and supersedes the ‘*Environment Agency Horizontal Guidance for Noise (H3) parts 1 and 2*’ and ‘*SEPA’s Guidance on the control of noise at PPC installations.*’

3.2.3. The guidance covers:

- how the environment agencies will assess noise from certain industrial processes;
- what the law says you must do to manage noise and vibration; and
- advice on how to manage noise – in particular, how to carry out a noise impact assessment and what operators should include in a Noise Management Plan (NMP)

- 3.2.4. The objective of the document is to assist in the regulation of noise from certain industrial processes and to protect and improve the environment, public health, and wellbeing.
- 3.2.5. It is advised that if noise is audible at noise sensitive receptors it could be *'possibly causing an impact'* and the operator must prevent significant pollution and comply with the requirement to use *'appropriate measures'* (Waste Framework Directive 2018/851), or *'best available techniques'* (BAT) to prevent or minimise noise pollution.
- 3.2.6. Advice is given on when noise assessment is needed, the standards expected, and the required competencies of the assessor. It is advised that noise assessments may be required by operators (or Permit applicants) at the application stage or when applying to vary a Permit, or to comply with specific Permit conditions.
- 3.2.7. Potential Noise Sensitive Receptors (NSRs) are to include residential properties, schools, hospitals, offices, public recreation areas, 'other NSRs' and noise sensitive habitats. Where noise may cause an impact at such receptors, the operator is required to carry out an assessment to determine the level of impact and how much work needs to be done to prevent or minimise the noise pollution. In respect to noise mitigation, the principle of Best Available Techniques (BAT) is referenced, employment of which is a legal defence against alleged noise nuisance.
- 3.2.8. To quantify the level of environmental noise impact from industrial sources (either existing or proposed) the guidance refers to the use of the assessment method detailed in BS 4142 (as summarised above), but goes on to state that in rare circumstances other methods may also be appropriate. The adoption of alternative assessment methods should be discussed and agreed with the regulator prior to commencement of the assessment work.
- 3.2.9. The guidance gives 4 steps to follow when undertaking noise impact assessment. These are summarised as follows:
- **Step 1: Desktop Risk Assessment.**  
This involves identifying and ranking in order of their off-site impact, any plant or operations that could be audible at any known (or proposed) NSRs. If noise emissions could cause pollution at an NSR, a noise impact assessment will be needed.
  - **Step 2: Off-Site Monitoring Survey.**  
Conducting a survey in line with BS4142 by a qualified acoustician, and using appropriate measurement equipment. The survey can be used to establish both prevailing industrial noise levels as well as the underlying background sound levels, and facilitate assessment in accordance with BS4142. It is stated that application of a minimum +3dB character correct is expected in the determination of industrial noise (rating) levels where a source is not tonal or impulsive but is readily distinguishable (unless no requirement for that correction can be robustly justified).
- It is stated that in the determination of background sound levels it should be ensured that there is not influence from site noise, and that the adopted background sound levels should be those that 'typically' prevail, i.e. not the lowest recorded values.
- Where the application is for a Permit variation, the assessment should consider all the noise resulting from the proposed variation, i.e. the existing site and the variation together. The

assessment should show both components clearly and then add them together to give a new total for site noise at the receptors.

■ **Step 3: Source Assessment.**

This step is to quantify the emissions from the noisiest items of plant or operations identified in Step 1, and then use that data to estimate the impact of these noise sources using BS4142 and/or modelling software. It should be recognised that there can be uncertainty associated with source sound level data and predictions. The level of noise impact as it relates to BS4142 can be described as follows:

- *Unacceptable level of audible or detectable noise* - This level of noise means that significant pollution is being, or is likely to be, caused at a receptor (regardless of whether you are taking appropriate measures). Further action must be taken, or operations may have to reduce or stop. The Environment Agency will not issue a Permit for operations likely to be at this level. The closest corresponding BS 4142 descriptor is '*significant adverse impact*' (following consideration of the context).
- *Audible or detectable noise* - This level of noise means that noise pollution is being (or is likely to be) caused at a receptor. There is a duty to use appropriate measures to prevent, or where that is not practicable, minimise noise. There is not a breach of requirements if appropriate measures are employed, but it will be necessary to rigorously demonstrate that the measures are appropriate. The closest corresponding BS4142 descriptor is '*adverse impact*' (following consideration of the context).
- *No noise, or barely audible or detectable noise* – This level of noise means that no action is needed beyond basic appropriate measures or BAT. The closest corresponding BS 4142 descriptor is '*low impact or no impact*' (following consideration of context). Low impact does not mean there is no pollution. However, if the impact is correctly assessed as low impact under BS4142, the Environment Agency may decide that taking action to minimise noise is a low priority.

■ **Step 4: BAT or Appropriate Measures Justification.** Present a justification that you are (or will be) using BAT to prevent or minimise polluting noise emissions.

- 3.2.10. With respect to noise modelling, reference is made the guidance contained within the Environment Agencies online guidance noted entitled: *Noise impact assessment involving calculators or modelling: Information you must submit to the Environment Agency in a Noise Impact Assessment that uses computer modelling or Spreadsheet calculation*. This online guidance note is summarised in **Section 3.3** below.
- 3.2.11. It is stated that noise modelling should apply the calculation method detailed in ISO 9613: *Acoustics – attenuation of sound during propagation outdoors*.
- 3.2.12. The guidance goes on to provide additional guidance and good practice for areas including: 'Vibration Impact Assessment', 'How context affects an assessment', 'Dealing with uncertainty', 'Weather conditions', 'Source directivity', 'Measurement', 'Monitoring locations', 'Monitoring durations', 'Manufacturers' sound power levels data', 'Attenuation predictions', 'Operator error', 'Equipment' and 'Soundscape assessments'.

- 3.2.13. The section entitled ‘*Appropriate measures to meet permit conditions*’ confirms that when looking at mitigation, the hierarchy of noise control should be as follows:
- prevent the generation of noise at source by good design, site layout and maintenance;
  - minimise or contain noise at source by following good operational techniques and management practice;
  - use effective silencers, physical barriers, or enclosures;
  - use sympathetic timing to control unavoidably noisy operations; and
  - where possible, increase the distance between the source and receptors.
- 3.2.14. Guidance is then also presented on control measures that should be considered to prevent or reduce noise pollution, stating that such measures should include, but not be limited to:
- assessing noise at different places and times to find where the problem is coming from;
  - maintaining equipment so noise levels are reduced (for example, balancing fans and fixing loose covers);
  - using enclosure or abatement (for example, acoustic enclosures, silencers, keeping doors and other openings in buildings closed);
  - timing your operations sympathetically (for example, do not plan any noisy maintenance work during evenings and weekends);
  - siting activities away from sensitive receptors (for example, locating vehicle routes or noisy plant as far away as possible from NSRs);
  - switching off plant, vehicles and ventilation units when not in use; and
  - Reducing, altering or stopping noisy activities until circumstances have changed, or you have put other appropriate measures in place, so operations can re-start without preventable, or significant adverse, noise impact.
- 3.2.15. The guidance goes on to include advice on engagement with neighbours and noise monitoring, and presents a suggested noise impact assessment report structure.

### **3.3 NOISE IMPACT ASSESSMENTS INVOLVING CALCULATIONS OR MODELLING: INFORMATION YOU MUST SUBMIT TO THE ENVIRONMENT AGENCY IN A NOISE IMPACT ASSESSMENT THAT USES COMPUTER MODELLING OR SPREADSHEET CALCULATION**

- 3.3.1. This document is the Environment Agency’s on-line guidance for noise assessment. The content of this document is as follows:

*“If you need to give the Environment Agency a noise impact assessment that uses computer modelling or spreadsheet calculations you must include the information listed in this guidance. This includes general information such as descriptions of your site and detailed noise data, usually displayed in tables.*

*You must also:*

- *clearly state any assumptions used in the computer model or spreadsheet*
- *submit all noise modelling files or spreadsheet calculations*
- *submit noise model input data in QSI data exchange format files where you have used noise modelling*

*If you do not provide all the information required, we may take longer to process your application.*

*We do not require assessments of off-site traffic or construction noise.*

### **General information you must provide**

*You must provide a description of:*

- *the site location and layout*
- *your proposed activities and sources of any noise*
- *local receptors and reasons for selection*
- *your noise remediation approach*

*You must also provide a:*

- *map showing the site and surrounding area including receptors*
- *Site plan including the site boundary*

*You must also provide a:*

- *full noise survey report if you have carried out a BS4142 assessment*
- *description of the noise mitigation measures you propose using and supporting evidence, such as the manufacturer's engineering specification for items that mitigate noise emissions, or calculations of the screening effect of barriers*

### **Noise data you must provide**

*You must provide the following information. You must use 1 metre resolution National Grid references for all location data.*

#### ***Fixed and mobile plant***

*You must provide the following information for fixed and mobile plant:*

- *grid references*
- *referenced or derived sound power levels (preferably octave band, for derived provide the measurements and calculations)*
- *heights*
- *directivities*
- *operating times*

#### ***Noise emitting buildings***

*You must provide the following information for noise emitting buildings:*

- *corner grid references*

- heights
- octave band reverberant sound pressure calculations or measurements
- referenced octave band transmission coefficients
- façade and roof emissions

You must also account for aperture emissions, providing:

- grid references
- dimensions
- sound power levels
- opening times

#### **Site traffic**

You must provide the following information about site traffic:

- grid references for site roads
- vehicle sound power levels
- traffic numbers
- traffic speed

#### **Site buildings**

For site buildings, whether acoustically emitting or not, provide:

- corner grid references
- heights

#### **Off-site buildings**

For any off-site buildings that may affect sound levels at receptors (through screening, reflection or diffraction), provide:

- corner grid references
- heights

#### **Site acoustic barriers**

You must provide the following information about site acoustic barriers:

- grid references at ends
- construction details
- thicknesses
- heights

#### **Terrain data**



*Where you are relying on screening by buildings or barriers for noise attenuation you must provide accurate elevations (height above sea level) and heights (above ground) for:*

- *sources*
- *barriers or buildings*
- *receptors*

*Use high resolution spot heights or contours.*

*You should incorporate the terrain data into the model. Do not submit separate copyrighted terrain files.*

### **Receptors**

*You must provide the following information about any receptors:*

- *grid references*
- *addresses or other identification*
- *number of storeys (estimate sound pressure levels for each storey)*
- *sensitivity*
- *BS4142 background LA90*
- *specific and rating levels for site activities*
- *rationale for applying or not applying acoustic penalties*
- *numerical impacts”*

## 4 BASELINE NOISE SURVEYS

---

### 4.1 BACKGROUND NOISE SURVEYS

- 4.1.1. The applicant has undertaken regular (circa annual) detailed baseline noise monitoring for the site, in particular the WPF, since 2018. That work has been extensive and included both source noise measurements of existing operational plant items, and the establishment of the prevailing background sound levels at a sample of the closest noise sensitive receptors to both the creamery and the WPF, and assessment in accordance with BS4142. The survey work is part of the facility's regular noise benchmarking activity allowing them to keep track of noise emissions, noise reductions achieved from site improvements and the identification of any arising noise emission issues so that they can be proactively addressed.
- 4.1.2. This previous baseline work was undertaken by Hepworth Acoustics with the findings detailed within the following technical reports:
- Hepworth Acoustics report reference: P18-098-R01v2, dated October 2018 and entitled *Dairy Crest WWTP<sup>2</sup>, Davidstow 2018 Baseline Noise Assessment*. [Hepworth Report 1].
  - Hepworth Acoustics report reference: P18-389-R01v2 dated November 2018 and entitled *Proposed developments at Dairy Crest Creamery / WWTP<sup>2</sup>, Davidstow Noise Impact Assessment*. [Hepworth Report 2].
  - Hepworth Acoustics report reference: P20-150-R01v1 dated April 2020 and entitled *Dairy Crest WWTP<sup>2</sup> April 2020 Noise Assessment*. [Hepworth Report 3].
  - Hepworth Acoustics report reference: P21-155-R01v1 dated May 2021 and entitled *Davidstow WPF April 2021 Noise Assessment*. [Hepworth Report 4].
- 4.1.3. In addition to the above, Hepworth Acoustics also undertook additional source noise measurements on the creamery and WPF at the time of work undertaken to inform Hepworth Report 3 and Hepworth Report 4. Those measurement data were obtained at the request of WSP to assist with this Permit variation application, with the obtained measurement data provided. The completed source noise measurements included plant items / noise sources that are comparable to some of those which from part of the changes at the site.
- 4.1.4. A summary of these surveys and the source noise measurement data that has been adopted within this assessment is presented in the sub-sections below.

### BACKGROUND SOUND LEVELS

#### Creamery

- 4.1.5. The latest receptor sound level data obtained in the vicinity of the creamery is that reported within Hepworth Report 2, and is summarised as follows.

---

<sup>2</sup> Waste Water Treatment Plant (WWTP), now referenced as the Water Processing Facility (WPF). For the purpose of this report, these acronyms can be considered interchangeable.

### Survey Dates

- 4.1.6. A series of early hour night-time sound level measurements were undertaken on two separate occasions. The first was between 00:26 and 02:38 hours on Friday 27 July 2018. The second was between 00:21 and 02:28 hours on Tuesday 7 August 2019.

### Measurement Locations

- 4.1.7. Measurements were undertaken at five locations selected as representative of the closest residential dwellings around the Creamery.
- 4.1.8. The completed measurements are described below. The location references are those used within Hepworth Report 2.
- Location 1 (St Kitts Farm). Five-minute measurements undertaken in the early hours of Friday 27 July 2018 and Tuesday 7 August 2018. Free-field. Microphone elevated to 1.5m above ground. Measurement at this location included contribution from the Creamery.
  - Location 2 (Nettings Park). Five-minute measurements undertaken in the early hours of Friday 27 July 2018 and Tuesday 7 August 2018. Free-field. Microphone elevated to 1.5m above ground. Measurement at this location included contribution from the Creamery.
  - Location 3 (Fowey Bungalow). Five-minute measurements undertaken in the early hours of Friday 27 July 2018 and Tuesday 7 August 2018. Free-field. Microphone elevated to 1.5m above ground. Measurement at this location included contribution from the Creamery.
  - Location 4 (Notties Park). Five-minute measurements undertaken in the early hours of Friday 27 July 2018 and Tuesday 7 August 2018. Free-field. Microphone elevated to 1.5m above ground. Measurement at this location included contribution from the Creamery.
  - Location 5 (The Bungalow). Five-minute measurements undertaken in the early hours of Friday 27 July 2018 and Tuesday 7 August 2018. Free-field. Microphone elevated to 1.5m above ground. Measurement at this location included contribution from the Creamery.

### Measured Noise Indices.

- 4.1.9. Measurements of the  $L_{Aeq,T}$ ,  $L_{Amax,F}$  and  $L_{A90,T}$  were obtained and reported, using a time interval of 5 minutes.

### Weather

- 4.1.10. For the duration of the measurements, weather data was provided from the weather station installed at the WPF. Measurements undertaken during the early hours of Friday 27 July were subject to light south-westerly / south-south-westerly winds, whilst measurements undertaken during the early hours of Tuesday 7 August were subject to light north / north-westerly winds.

### Measurement Equipment

- 4.1.11. All measurement equipment conformed to Type 1 specification and was calibrated at the beginning and end of the measurements with no variation in the calibrated levels observed. The measurement microphones were fitted with windshields and mounded in free-field conditions at all locations.

### Prevailing noise environment

- 4.1.12. A summary of the typical measured  $L_{A90,T}$  noise levels are presented in **Tables 4-1** below.

**Table 4-1 – Typical Measured Background Sound Levels, Free-field – Locations 1 to 5**

Location	Background Sound Level, dB $L_{A90,5min}$		
	Night-time (SW/SSW winds)	Night-time (N/NW winds)	Night-time (all directions) - Average
1 St Kitts Farm (including creamery)	36 to 39 (mean 37)	29 to 34 (mean 31)	34
2 Nettings Park (including creamery)	41 to 42 (mean 41)	29 to 31 (mean 30)	36
3 Fowey Bungalow (including creamery)	31 to 36 (mean 34)	34 to 39 (mean 37)	36
4 Notties Park (including creamery)	37 to 42 (mean 40)	41 to 44 (mean 43)	42
5 The Bungalow (including creamery)	42 to 43 (mean 42)	32 to 34 (mean (33))	38

### Water Processing Facility

- 4.1.13. The background sound level survey detailed within Hepworth Report 1 was undertaken in 2018 and presents the results of measurements undertaken at four locations (Locations A, B, C and D as described below). The background sound level survey detailed within Hepworth Report 3 was undertaken in 2020, and presents the results of measurements undertaken just at Location A. The background sound level data detailed within Hepworth Report 4 was undertaken in 2021 and also presents the results of measurements undertaken just at Location A.
- 4.1.14. The latest data obtained for each measurement location is summarised below and has been adopted within this report.

### Survey Dates

- 4.1.15. The 2018 sound level survey was undertaken over the period 17:00 hours on Thursday 26 July to 13:00 hours on Tuesday 7 August 2018. The survey therefore extended over approximately a 12-day period.
- 4.1.16. The 2020 sound level survey was undertaken over the period 15:00 hours on Thursday 09 April until 15:00 hours Thursday 16 April. The survey therefore extended over approximately a 7-day period.
- 4.1.17. The 2021 sound level survey was undertaken over the period 19:00 hours on Monday 19 April 2021 until 11:00 hours Tuesday 29 April 2021. The data during the period 07:00-19:00 hours on Tuesday 20 April was deemed unsuitable due to a technical problem on site. The survey therefore extended over approximately a 9-day period.

### Measurement Locations and Durations

- 4.1.18. During the 2018 survey, measurements comprised a combination of both long-term continuous measurements and short-term attended measurements. Measurements were undertaken at a sample of locations selected as being representative of the closest residential properties around the WPF.

- 4.1.19. It was considered that, due to the long-standing operation of the WPF and creamery, noise from these facilities is an intrinsic component of the prevailing background sound levels at the closest noise sensitive receptors. Measurements were therefore undertaken to establish the prevailing noise levels including contribution from these facilities. This included measurements at Trewassa (Location A) and Treworra (Location B), where the closest dwellings to the WPF are located.
- 4.1.20. However, in addition, measurements were also undertaken at locations screened from the WPF in order to determine 'notional' background ( $L_{A90}$ ) sound levels in absence of contribution from the WPF (Locations C and D).
- 4.1.21. During the 2020 survey, a single long-term measurement was undertaken at Location A, constituting an update of the measurements previously undertaken at this location in 2018.
- 4.1.22. Another single long-term measurement was undertaken at Location A during the 2021 survey, constituting another update of the measurements previously undertaken at this location in 2020 and 2018.
- 4.1.23. The latest measurement data for each Location is presented below. The Location references are those used within Hepworth Report 1.

#### Long Term Continuous Measurements

- Location A<sup>3</sup> (Trewassa). Representative of the closest dwellings to the north-north-west of the WPF. Comprising a single continuous measurement between 15:00 hours on Thursday 09 April until 15:00 hours Thursday 16 April 2020. Free-field. Microphone elevated to 3m above ground. Measurements at this location included contribution from the WPF.

#### Short Term Continuous Measurements

- Location B (Treworra). Representative of the closest dwellings to the east of the WPF. Comprising shorter attended measurements between 00:15 and 03:00 on Friday 27 July 2018 (light south-west / south-south-westerly winds) and between 00:00 and 02:30 on Tuesday 7 August 2018 (light north / north-westerly winds). Free-field. Microphone elevated to 2m above ground. Measurement at this location included contribution from the WPF.
  - Location C (Treworra north). This location was positioned 3.5m behind a barn/warehouse such that this structure provided screening to both the WPF and the creamery. Five minute measurements undertaken in the early hours of Friday 27 July 2018 and Tuesday 7 August 2018. Free-field. Microphone elevated to 1.5m above ground. Measurement at this location did not include contribution from WPF.
  - Location D (Lilli Park / Penmarrod). This location was in a valley and hence shielded from distant sources of noise, including the WPF. Five minute measurements undertaken in the early hours of Friday 27 July 2018 and Tuesday 7 August 2018. Free-field. Microphone elevated to 1.5m above ground. Measurement at this location did not include contribution from WPF.
- 4.1.24. Measurements of the  $L_{Aeq,T}$ ,  $L_{Amax,F}$  and  $L_{A90,T}$  were obtained and reported, using a time interval of 15 minutes at Locations A and B and 5 minutes at C and D.

---

<sup>3</sup> Also referred to as Location 6 in Hepworth Report 2

### Weather

- 4.1.25. For the duration of the measurements, weather data was provided from the weather station installed at the WPF.
- 4.1.26. Measurements undertaken during the early hours of Friday 27 July (Locations B, C and D) were subject to light south-westerly / south-south-westerly winds, whilst measurements undertaken during the early hours of Tuesday 7 August (locations B, C and D) were subject to light north / north-westerly winds.
- 4.1.27. Measurements undertaken during the 2020 survey (Location A) were subject to variable wind speed and direction conditions, as expected over the adopted 7 days period. The reporting does not detail any rain affected periods.
- 4.1.28. Measurements undertaken during the 2021 survey (Location A) were also subject to variable wind speed and direction conditions, but it is reported that over the measurement period the wind direction was generally northerly and easterly, leading to the expectation of slightly lower noise levels. The reporting does not detail any rain affected periods.

### Measurement Equipment

- 4.1.29. All measurement equipment conformed to Type 1 specification and was calibrated at the beginning and end of the measurements with no variation in the calibrated levels observed. The measurement microphones were fitted with windshields and mounted in free-field conditions at all locations.

### Prevailing noise environment

- 4.1.30. Over the course of the surveys, operations at the WPF were understood to be generally normal and routine, with minor exceptions as detailed in the associated Hepworth Reports. It is considered that these short exceptions are not significant in the determination of the resulting representative noise levels at each measurement location.
- 4.1.31. At measurement Locations A and B, a direct correlation between wind speed / direction and resulting measured noise levels was identified. It was also identified that the  $L_{Aeq}$  and corresponding  $L_{A90}$  values were typically close in value, indicating that the noise levels were generally steady over the course of the measurement periods.
- 4.1.32. A summary of the typical measured  $L_{A90,T}$  sound levels are presented in **Table 4-2** below.

**Table 4-2 – Typical Measured Background Sound Levels,  $L_{A90,T}$ , Free-field, dB – Locations A to D**

Locations	Hepworth Report	$L_{A90,T}$	
		Daytime	Night-time
A (including WPF)	4 (2021)	39 to 50 (mean 45)	40 to 49 (mean 45)
	3 (2020)	39 to 51 (mean 46)	40 to 49 (mean 47)
	1 (2018)	38 to 49 (mean 43)	39 to 46 (mean 43)
B (including WPF)	1 (2018)	-	27 July 2018: 31-35 (mean 33) 7 August 2018: 25-29 (mean 28)

C and D (excluding WPF)	1 (2018)	-	27 July 2018: 27 to 30 dB(A) 7 August 2018: 20 to 22 dB(A)
-------------------------	----------	---	---

- 4.1.33. As seen in **Table 4-2** above, background sound levels at Location A have been fairly consistent over the last three surveys which have spanned a three year period (2018 to 2021). The latest measurement period at Location A, from Hepworth Report 4 (2021), shows mean background sound levels in between those of the previous reports, and is considered to be the most up-to-date and representative of the current background sound levels at Location A. These data have therefore been presented in bold type.
- 4.1.34. Measurements at Locations B, C and D have not been repeated and are still the most representative of the current sound levels at those locations.



## 5 SOURCE NOISE DATA

---

### 5.1 CREAMERY

#### HEPWORTH MEASUREMENT DATA

**Table 5-1** below presents the measured source noise level data used to inform the predictive assessment of noise from the site changes at the creamery. These data have been adopted from Hepworth Report 2, and also include measurement results obtained by Hepworth at the times of their surveys as reported in Hepworth Report 3 and Hepworth Report 4. These additional measurement results were specifically requested by WSP to inform this Permit variation noise assessment.





**Table 5-1 – Source Noise Measurement Results - Creamery**

Data Reference	Description	Distance (m)	Noise Level L <sub>90</sub> dB (Linear)																			
			Octave Band Centre Frequency (Hz)																			
			50	63	80	100	125	160	200	250	315	400	500	630	800	1000	1250	1600	2000	2500	3150	4000
2021_Hep_CRM_2_3_4	Agitator / Mixers	1	57.9	62.0	61.2	74.1	57.3	54.9	58.6	60.9	57.4	55.5	58.3	63.0	62.7	61.1	57.6	59.2	56.8	52.4	51.5	49.0
2020_Hep__CRM_1a	Silo	1	59.2	54.7	48.7	47.6	48.8	51.7	53.2	56.7	51.7	50.8	51.0	51.2	53.7	51.5	48.2	44.1	41.4	37.8	36.5	35.0
2020_Hep__CRM_1b	Silo	1	53.4	58.6	54.8	50.8	48.5	47.7	48.5	49.0	50.9	47.9	50.0	50.0	50.0	49.8	46.7	43.8	43.6	41.2	37.5	35.0
2020_Hep__CRM_12b	Silo	1	66.3	62.1	61.2	61.8	53.6	55.9	53.9	53.8	50.3	49.7	51.0	48.2	46.6	47.1	46.4	46.1	44.2	42.6	40.3	38.0
2020_Hep__CRM_13b	Silo	1	66.7	63.4	62.8	59.1	54.3	54.9	54.3	54.9	51.3	51.9	51.8	48.0	46.8	46.6	46.6	45.6	44.3	43.5	40.6	38.0
2020_Hep__CRM_14b	Silo	1	69.0	63.9	59.0	57.9	56.3	56.7	56.2	56.5	52.1	52.7	53.5	49.9	48.8	47.5	47.5	47.0	46.7	45.9	43.2	41.0
AVERAGE_SILO <i>[average of 4 rows above]</i>	Silo	1	65.5	61.6	59.4	58.0	53.3	54.4	53.8	54.9	51.3	50.9	51.6	49.6	50.0	48.9	47.1	45.5	44.4	43.0	40.3	38.0
2021_Hep_CRM_18	Inside GOS Bulk Loading CIP Container	Internal Reverberant	60.3	50.6	57.7	55.4	51.9	43.5	41.8	43	45.2	43.1	48.4	47.8	47.9	48.9	46.9	45.1	42.6	43.5	41	40.0
2021_Hep_CRM_20	Lagoon OCU motor	1	67	63	63	61	56	63	58	61	64	61	62	63	64	64	64	63	61	56	52	49

## MANUFACTURERS' DATA

- 5.1.1. In addition to the above, the following manufacturers' source noise data is presented within **Appendix C**:
- SPX Waukesha Cherry-Burrell S Series Fixed Mounted Mixer – maximum 85dB(A) at 1m.
  - SPX Lightnin XDQ-117 Top Mixers – maximum 85dB(A) at 1m.
- 5.1.2. Whilst the SPX source data states a maximum noise emission level of 85dB(A) @ 1m, the manufacturer data goes on to state that “*the equipment does not produce high noise or vibration. However, the operator may experience high noise or vibration in the location of this equipment due to another source.*” This indicates that the stated ‘maximum’ is simply confirmation that the source does not generate levels above upper action level set out in *The Control of Noise at Work regulations, 2005*. This has been confirmed in discussions with the manufacturer who has stated that the expected levels for the agitator and mixers are significantly lower than those stated in the product literature, more typically **70dB(A) at 1m**, consistent with Data Reference 2021\_Hep\_CRM\_2\_3\_4 in the **Table 5-1** above.

## 5.2 WATER PROCESSING FACILITY (WPF)

### HEPWORTH MEASUREMENT DATA

- 5.2.1. **Table 5-2** below present the measured source noise level data used to inform the predictive assessment of noise from the site changes at the WPF. These data have been adopted from Hepworth Reports 1, 3 and 4, supplemented with the results of additional measurements undertaken by Hepworth at the time of those reported surveys. These additional measurement results were specifically requested by WSP to inform this Permit variation noise assessment.



**Table 5-2 – Source Noise Measurement Results – WPF**

Data Reference	Description	Distance (m)	Noise Level, dB L <sub>90</sub> (Linear)																				
			Octave Band Centre Frequency (Hz)																				
			50	63	80	100	125	160	200	250	315	400	500	630	800	1000	1250	1600	2000	2500	3150	4000	5000
2021_Hep_WPF_18	DAF Open Roller Shutter Door	5	28.8	25.8	34.5	36.9	40.9	41.6	46.1	47.4	50.4	52.8	54.8	54.1	56.2	56	57.6	58	56.2	54.3	52.2	52	50.5
2020_Hep_WPF_12	DAF Facades and Roof	5	22	25	28	32	36	40	41	43	43	48	48	53	52	53	51	49	46	45	42	39	35
2021_Hep_WPF_44	Between Fan Stack and Dry Scrubber 2	1	71	64	62	67	68	66	63	62	65	62	64	64	65	68	67	64	64	58	58	58	60
2021_Hep_WPF_45	Between Dry2 and Dry Scrubber 1	1	64	61	60	62	61	59	61	60	60	61	60	58	58	59	58	58	55	54	55	54	52
2021_Hep_WPF_46	Between Dry Scrubber 1 and Wet Scrubber	1	64	58	60	61	60	61	61	57	58	60	60	58	58	58	59	58	57	57	55	54	53
2021_Hep_WPF_47	Pump on North Side of BT1	1	62	59	61	57	61	59	59	60	58	60	63	60	65	66	69	71	62	59	65	64	51
2021_Hep_WPF_48	Pump on West side of BT1	1	61	59	60	59	60	62	62	61	60	63	63	63	68	68	68	67	65	64	63	60	56
2021_Hep_WPF_49	Pump on South Side of BT1	1	67	63	64	63	65	67	65	62	65	66	68	66	68	70	71	67	67	62	60	58	54
2021_Hep_WPF_50	Pump on East Side of BT1	1	60	61	63	62	63	64	63	62	64	64	67	65	70	71	72	70	67	65	63	61	58

## WSP SOURCE NOISE SURVEY

- 5.2.2. WSP undertook a supplementary noise survey at the WPF on 1 February 2022. The purpose of the survey was to measure noise levels from the installed proprietary downstream tertiary filters, as manufacturers' noise data was not sufficient, and these had become operational at the site after the previous surveys by Hepworth.
- 5.2.3. The tertiary filtration system is installed downstream of the gravity settlement tank ST2. There are three units that form the tertiary filtration system and they operate in a duty / duty / clean mode. During our site visit the centre and right hand units were in duty mode, and the left hand unit was in clean mode. The units operate intermittently for up to 2 minutes at a time. The dominant noise associated with the tertiary filters is the sound of water flowing out of the front of the items, no mechanical noise is audible. Measurements of the right hand unit were taken via the gantry steps, at a distance of approximately 1m from the noise source (water flow).
- 5.2.4. After the water is cleaned in the tertiary filters it flows into the filtrate tank. The dominant noise associated with the filtrate tank is the sound of water flowing in (from the tertiary filters), no mechanical noise is associated with the filtrate tank. Measurements of water entering the filtrate tank were taken, at a distance of approximately 1m from the noise source (water flow).
- 5.2.5. Water from the filtrate tank is transferred to WRP and W2 by the transfer pumps. There are two pairs of transfer pumps, which operate in a duty / standby mode. The dominant noise associated with the transfer pumps is the sound of the motors. During our site visit the transfer pumps to the left of the filtrate tank were operating continuously, and the transfer pumps to the right of the filtrate tank were operating intermittently for approximately 1 minute. Measurements of the transfer pumps were taken, at a distance of approximately 1m from the noise source (motor). The pumps to the left of the filtrate tank have a 4 kHz tone, although this is only obvious in close proximity. The pumps to the right are not tonal, having more broadband energy in the higher frequency range (>4kHz) when compared against the transfer pumps on the left hand side.
- 5.2.6. At approx. 1 m, the tertiary filtration system equipment is the dominant noise source (during operation). However, even at a short distance away, ~3m, noise from other plant and equipment becomes the dominant source. At the site there are a large number of noise generating activities in the area surrounding the tertiary filtration system. In addition, the noise generated by the tertiary filters and the filtrate tank is water flow, and at a position away from the equipment, this noise source is screened by the sides of the equipment.
- 5.2.7. The survey was carried out using the Class 1 measurement equipment, as detailed in **Table 5-3**. The measurement system had been calibrated to traceable standards within the previous 24 months, and the field calibrators had been calibrated within the previous 12 months. The system was calibrated on-site before starting and after finishing the measurements, no significant drift occurred during the survey. Copies of the calibration certificates are available on request

**Table 5-3 – Measurement Equipment**

ID	Equipment	Manufacturer & Type	Serial number
Rion 4	Sound Level Meter	Rion NL52	01021292
	Pre-amplifier	Rion NH25	21334
	Microphone	Rion UC59	19829
	Calibrator	Rion NC74	35125825

- 5.2.8. The weather conditions for during the attended survey were appropriate for sound level measurements. The wind speeds did not exceed 5m/s and the wind direction was westerly. The temperature was 8°C. Conditions were dry and the cloud cover was 100%.
- 5.2.9. Short-term (1 minute) measurements were recorded of the equipment in operation. Measurements were taken at distances of approximately 1m from each noise source. The height of the measurements was variable due to the location of the equipment.
- 5.2.10. **Table 5-4** below presents the measured source noise level data used for the downstream tertiary filters in the assessment.



**Table 5-4 – Downstream Tertiary Filter Source Noise Measurement Results**

Data Reference	Description	Distance (m)	Noise Level, dB L <sub>90</sub> (Linear)																			
			Octave Band Centre Frequency (Hz)																			
			50	63	80	100	125	160	200	250	315	400	500	630	800	1000	1250	1600	2000	2500	3150	4000
2022_WSP_WPF_1	Tertiary Filtrate Tank Input	1	60.3	56.2	59.3	65.5	59.2	60.3	59.3	58.4	62.0	62.8	62.9	65.4	64.6	64.3	63.5	62.1	61.3	60.3	59.8	58.8
2022_WSP_WPF_2	Tertiary Transfer Pumps	1	59.6	56.6	59.1	59.2	55.5	55.6	54.4	54.7	58.2	56.7	57.0	56.6	55.7	57.5	59.4	55.7	53.7	53.0	53.8	62.4
2022_WSP_WPF_3	Tertiary Transfer Pumps	1	58.0	53.7	57.6	57.9	54.3	54.0	55.2	54.8	56.6	54.7	56.5	58.1	60.6	56.7	57.2	56.9	54.6	53.8	56.4	57.4
2022_WSP_WPF_2_3 <i>[Average of two lines above]</i>	Tertiary Transfer Pumps	1	58.9	55.4	58.4	58.6	54.9	54.9	54.8	54.8	57.5	55.8	56.8	57.4	58.8	57.1	58.4	56.3	54.2	53.4	55.3	60.6
2022_WSP_WPF_4	Tertiary Filters Output	1	60.1	58.1	66.1	66.7	62.6	58.9	60.4	59.7	63.1	60.8	60.9	62.5	62.7	64.3	63.2	64.0	63.3	63.5	63.2	62.8

## 6 NOISE MODEL AND PREDICTION RESULTS

---

### 6.1 SUMMARY

- 6.1.1. A detailed noise model has been prepared to determine the noise levels that would be generated by the site changes associated with the proposed Permit variation. The noise model has been prepared within the CadnaA® PC-based proprietary noise modelling suite. The model has included each of the noise sources that have been scoped-in to this assessment, as detailed in **Section 2.2** (i.e. those sources with the greatest potential to give rise to a change in the noise environment at local receptors).
- 6.1.2. The approach to modelling each source is further described in **Section 6.3** below.

### 6.2 APPROACH

#### TOPOGRAPHY, BUILDINGS, PLANS, RECEPTORS

- Existing aerial photography and Ordnance Survey (OS) mapping for the site and surrounding area was calibrated into the noise model based on OS six figure grid references.
- 0.5m ground contours were generated from the latest available LiDAR (DTM) 1m posting data covering the full site and surrounding area.
- The in-situ acoustic fence and perimeter containment wall as installed at the WPF were incorporated into the noise model as acoustic barriers.
- Scaled schematic drawings for the existing creamery and WPF were calibrated into the noise model based on OS six figure grid references.
- Scaled schematic drawings of the proposed site changes were calibrated into the noise model based on OS six figure grid references.
- Receptors were incorporated at each of the closest dwellings to the site, at free-field locations and with heights of 4m above local ground.

#### MODEL SETTINGS

- 3<sup>rd</sup> order reflections were set to be included within the completed noise level calculations.
- Local ground was set to be acoustically absorptive ( $G=1$ ), to represent the surrounding area being mostly open farmland.
- The model was set to implement the ISO:9613-2: *Acoustics – Attenuation of sound during propagation outdoors – Part 2: General method of calculation noise level prediction method*.
- Temperature was set to 10°C and humidity to 70% so that atmospheric absorption was accounted for.
- Building facades (including cylinders and acoustic barriers), were set to have absorption coefficients of no greater than 0.1.



## 6.3 MODELLED SOURCES

### CREMAERY

#### Project #2 Milk Protein Standardisation

- 6.3.1. The two possible future raw milk silos have been modelled as cylindrical vertical area sources, each with a point source to represent the associated mixer / agitator.

**Table 6-1 – Creamery Project #2 Modelled Noise Sources**

Source	Source Type	Coordinates			Radius (m)	Source Noise Data	Notes
		X	Y	Z			
New Raw Milk Silo 1	Cylindrical Vertical Area Source	213696	86597	19.5	2.5	'AVERAGE_SILO' - Spectra applied and increased in model to give total determined from on-site measurements (60.6dB(A) @ 1m)	X-Y = centre
New Raw Milk Silo 2	Cylindrical Vertical Area Source	213691	86593	19.5	2.5		X-Y = centre
New Raw Milk Agitator / Mixer 1	Point Source	213693	86597	10	-	'2021_Hep_CRM_2_3_4' - Converted to sound power level (Lw) and applied directly	-
New Raw Milk Agitator / Mixer 2	Point Source	213692	86596	10	-		-

#### Project #3 Milk Protein Standardisation

- 6.3.2. The two possible future cream silos have been modelled as cylindrical vertical area sources, each with a point source to represent the associated mixer / agitator.
- 6.3.3. The Freezer building has been modelled as 5 area noise sources, four vertical (one for each façade), and one horizontal (roof).





**Table 6-2 – Creamery Project #3 Modelled Noise Sources**

Silos

Source	Source Type	Coordinates			Radius (m)	Source Noise Data	Notes
		X	Y	Z			
New Cream Silo 1	Cylindrical Vertical Area Source	213684	86597	24	1.5	'AVERAGE_SILO' - Spectra applied and increased in model to give total determined from on-site measurements (60.6dB(A) @ 1m)	X-Y = centre
New Cream Silo 2	Cylindrical Vertical Area Source	213681	86595	24	1.5		X-Y = centre
New Cream Agitator / Mixer 1	Point Source	213684	86597	24.25	-	'2021_Hep_CRM_2_3_4' - Converted to sound power level (Lw) and applied directly.	-
New Cream Agitator / Mixer 2	Point Source	213681	86595	24.25	-		-

Freezer Building

Source	Source Type	Coordinates					Source Noise Data	Notes
		Start		End		Height		
		X	Y	X	Y	Z		
New Freezer Room West Façade	Vertical Area Source	213718	86533	213722	86528	5	'Client _1' - Each façade and roof element calibrated in noise model to give stated maximum of 60dB(A) at 1m.	-
New Freezer Room South Façade	Vertical Area Source	213722	86528	213732	86534	5		-



New Freezer Room East Façade	Vertical Area Source	213732	86534	213729	86540	5		-
New Freezer Room North Façade	Vertical Area Source	213729	86540	213718	86533	5		-
New Freezer Room Roof	Horizontal Area Source	Rectangular on top of above façades				5		-

### Project #5 GOS Bulk Loading

- 6.3.4. The new GOS Bulk Loading building has been modelled as 6 area noise sources, five vertical (one for each the three outward facing façades and one for each of the two roller shutter doors), and one horizontal (roof).
- 6.3.5. The bulk loading containerised CIP is made of steel and so has little / no noise break-out, with the possible exception of noise through its three louvres, so this item has been modelled as three vertical area sources (one for each louvre). Louvres have been assumed to be non-acoustic with no insertion loss.



**Table 6-3 – Creamery Project #5 Modelled Noise Sources**

Source	Source Type	Coordinates					Source Noise Data	Notes
		Start		End		Height		
		X	Y	X	Y	Z		
New GOS Bulk Loading Western Cladding	Vertical Area Source	213797	86408	213800	86403	6.5	Spectral data ref. '2021_Hep_CRM_18' applied to internal reverberant level 'Client_2' (80dB(A)), and noise break-out calculations undertaken to determine sound power level (L <sub>w</sub> ) of each building element	Extending from 6.5m down to 4.1m (i.e. above roller shutter door)
New GOS Bulk Loading Southern Façade	Vertical Area Source	213800	86403	213819	86414	6.5		Full height from ground
New GOS Bulk Loading Eastern Cladding	Vertical Area Source	213819	86414	213816	86419	6.5		Extending from 6.5m down to 4.1m (i.e. above roller shutter door)
New GOS Bulk Loading Western Roller Shutter	Vertical Area Source	213798	86407	213800	86404	5		Full height from ground
New GOS Bulk Loading Eastern Roller Shutter	Vertical Area Source	213819	86415	213816	86418	5		Full height from ground
New GOS Bulk Loading Roof	Horizontal Area Source	Rectangular on top of above façades				6.5		-
New Containerised GOS CIP Louvre1	Vertical Area Source	213806	86404	213806	86404	1.5		Measured internal reverberant level ref. '2021_Hep_CRM_18' applied and noise break-out calculations
New Containerised GOS CIP Louvre2	Vertical Area Source	213808	86404	213808	86404	1.5	Full height from ground	



New Containerised GOS CIP Louvre3	Vertical Area Source	213811	86407	213811	86407	1.5	undertaken to determine sound power level (Lw) of each building element	Full height from ground
-----------------------------------	----------------------	--------	-------	--------	-------	-----	---	-------------------------

## WPF

### Contingency Lagoon & Odour Control Unit (OCU)

- 6.3.6. New Contingency Lagoon Odour Control Unit modelled as single point source at the location of the motor (the only noise emission source).

**Table 6-4 – Contingency Lagoon & OCU Modelled Noise Sources**

Source	Source Type	Coordinates			Source Noise Data	Notes
		X	Y	Z		
New Lagoon OCU Motor	Point Source	213904	86455	0.5	'2021_Hep_CRM_20' - Converted to Sound Power Level and applied directly	-

### Two New Dissolved Air Floatation Units (DAFs)

- 6.3.7. DAF2 and DAF3 each modelled as 6 areas sources, 5 vertical (one for each façade and 1 for the roller shutter door) and 1 horizontal (roof).

**Table 6-5 – Two New DAFs Modelled Noise Sources**

Source	Source Type	Coordinates					Source Noise Data	Notes
		Start		End		Height		
		X	Y	X	Y	Z		



DAF2 West Facade	Vertical Area Source	214863	86584	214863	86571	4.0	'2020_Hep_WPF_12' - Applied to DAF2 façades and roof as sound power per unit area (Lw") and level adjusted so model predicts measured result at Location ref. 2020_Hep_WPF_12	-
DAF2 South Facade	Vertical Area Source	214863	86571	214871	86572	4.0		-
DAF2 East Facade	Vertical Area Source	214871	86572	214871	86583	4.0		-
DAF2 North Facade	Vertical Area Source	214870	86583	214863	86584	4.0		-
DAF2 Roof	Horizontal Area Source	Trapezoidal on top of above façades				4.0		-
DAF2 Open Roller Shutter	Vertical Area Source	214871	86580	214871	86582	3.0	'2020_Hep_WPF_18' - Applied to DAF2 roller shutter door as sound power per unit area (Lw") and level adjusted so model predicts measured result at location ref. 2020_Hep_WPF_18.	-
DAF3 West Facade	Vertical Area Source	214866	86592	214865	86585	4.5	'2020_Hep_WPF_12' – Applied to DAF3 facades and roof as sound power per unit area (Lw") with the same adjustment as used for DAF2	-
DAF3 South Facade	Vertical Area Source	214865	86585	214879	86583	4.5		-
DAF3 East Facade	Vertical Area Source	214879	86583	214880	86590	4.5		-
DAF3 North Facade	Vertical Area Source	214880	86590	214866	86592	4.5		-
DAF3 Roof	Horizontal Area Source	Rectangular on top of above façades				4.5		-

DAF3 Open Roller Shutter	Vertical Area Source	214875	86584	214878	86583	4.5	'2020_Hep_WPF_12' – Applied to DAF3 roller shutter door as sound power per unit area (Lw'') with the same adjustment as used for DAF2	-
--------------------------	----------------------	--------	-------	--------	-------	-----	---	---

### Balancing Tank 1 (BT1) and Divert Tanks OCU

6.3.8. This OCU has been modelled as three point sources that represent the three adopted measurement locations.

**Table 6-6 – Contingency Lagoon OCU Modelled Noise Sources**

Source	Source Type	Coordinates			Source Noise Data	Notes
		X	Y	Z		
BT1 and Divert Tank OCU Source 1	Point Source	214849	86563	1	'2021_Hep_WPF_44' - Converted to Sound Power Level (L <sub>w</sub> ) and applied directly	-
BT1 and Divert Tank OCU Source 2	Point Source	214845	86562	1	'2021_Hep_WPF_45' - Converted to Sound Power Level (L <sub>w</sub> ) and applied directly	-
BT1 and Divert Tank OCU Source 3	Point Source	214840	86562	1	'2021_Hep_WPF_46' - Converted to Sound Power Level (L <sub>w</sub> ) and applied directly	-

### Downstream Tertiary Filters

6.3.9. Modelled as 6 point sources, two representing each pair of transfer pumps, two for the filtrate tank inputs (only two of three operate at any one time), and two for the tertiary filter outputs (only two of three operate at any one time).



**Table 6-7 – Downstream Tertiary Filter Modelled Noise Sources**

Source	Source Type	Coordinates			Source Noise Data	Notes
		X	Y	Z		
New Transfer Pumps 1	Point Source	214878	86560	0.5	'2022_WSP_WPF_2_3' - Converted to Sound Power Level and applied directly	-
New Transfer Pumps 2	Point Source	214880	86567	0.5		-
New Filtrate Tank Input 1	Point Source	214878	86562	1.0	'2022_WSP_WPF_1' - Converted to Sound Power Level and applied directly	-
New Filtrate Tank Input 2	Point Source	214879	86566	1.0		-
New Tertiary Filters Output 1	Point Source	214879	86561	1.5	'2022_WSP_WPF_4' - Converted to Sound Power Level and applied directly	-
New Tertiary Filters Output 2	Point Source	214880	86565	1.5		-

**New Aeration Pumps for BT1**

Modelled as four point sources.

**Table 6-8 – New Aeration Pumps for BT1 Modelled Noise Sources**

Source	Source Type	Coordinates			Source Noise Data	Notes
		X	Y	Z		
New Pump on North Side of BT1	Point Source	214846	86588	1.0	'2022_WSP_WPF_47' - Converted to Sound Power Level (L <sub>w</sub> ) and applied directly	-
New Pump on West Side of BT1	Point Source	214839	86574	1.0	'2022_WSP_WPF_48' - Converted to Sound Power Level (L <sub>w</sub> ) and applied directly	-



New Pump on South Side of BT1	Point Source	214852	86566	1.0	'2022_WSP_WPF_49' - Converted to Sound Power Level ( $L_w$ ) and applied directly	-
New Pump on East Side of BT1	Point Source	214861	86580	1.0	'2022_WSP_WPF_50' - Converted to Sound Power Level ( $L_w$ ) and applied directly	-



## 6.4 RECEPTOR NOISE LEVELS

- 6.4.1. The model has been used to determine the Specific sound levels that would arise from elements scoped-in to this assessment, for all of the receptors listed in table **Tables 2-1 and 2-2**.
- 6.4.2. The resulting calculated receptor Specific sound levels are presented in **Table 6-1** with a noise contour map presented in Figure D1 of Appendix D.
- 6.4.3. All predictions have been undertaken at 4m above ground in accordance with EA guidance, although it would be more typical to predicted daytime noise level at 1.5m where lower results are typical due to increased ground absorption and acoustic screening.

**Table 6-9 – Receptor Specific Noise Levels, dB(A) L<sub>s</sub>**

Receptor Ref.	Receptor Name	Specific Sound Level, dB L <sub>s</sub> / L <sub>Aeq,T</sub>
R01	Treveth	22.9
R02	The Pines	21.8
R03	Trehane House	22
R04	Tremblary Cottage	11
R05	Trewinnow Bungalow	8.9
R06	Canapark	14.4
R07	45 Inny Vale	8.8
R08	Ivydene	11
R09	Fowey Bungalow	26.6
R10	Homeleigh	24.3
R11	Barn Park Bungalow	22.3
R12	Owls Gate, Treworra	23.9
R13	4 Lillipark	24
R14	Penmarrod	17.9
R15	St. Lawrence, Tremain	13.7
R16	Oxencombe, Tremain	13.6
R17	Bell View, Davidstow	15.6
R18	Hendawle Farm	16.9

R19	Higher Tremail Farm	13.3
R20	Butterwell, Davidstow	20.7
R21	Nettings Park, Davidstow	30.3
R22	Rose Tree Cottage, Davistow	19.4
R23	Moor View Farm, Davidstow	21.8
R24	Newhouse, Davidstow	22
R25	Tresplatt Farm, Davidstow	23.6
R26	Wayside, Davidstow	24.7
R27	Victoria, Davidstow	24.8
R28	Moorcroft, Davidstow	26.1
R29	The Bungalow, Davidstow	22.5
R30	Barnpark Farm, Davidstow	17.5
R31	Greenwold Cottage, Trewessa	36.8
R32	Tremar Cottage, Trewassa	32.6
R33	Wicketts Cottage, Trewassa	35.1
R34	Greenvally Bungalow, Trewassa	34.2
R35	Lowertown, Trewassa	29.7
R36	Manor Park, Trewassa	25.5
R37	Rest Holme, Trewassa	28.3
R38	Trewassa Flats	28.8
R39	Treworra Barton	22.5
R40	Nottles Park	25.9
R41	Old Firge Cottage	11.4
R42	St Kitts Farm	27.6

## 7 ASSESSMENT

- 7.1.1. **Table 7-1** below presents a comparison of the predicted noise levels from the proposed Permit Variation, with those that were found to prevail at receptors prior to the commencement of the projects / plant falling under the proposed Permit Variation (taken from **Table 4-1** and **Table 4-2**).
- 7.1.2. **Table 7-1** includes each of the closest receptors to the creamery and WPF, where baseline noise monitoring was previously undertaken.
- 7.1.3. Given the nature of the sources, their locations, and the distances to receptors, noise from the items under the proposed Permit Variation are not anticipated to be readily distinguishable, or have any acoustic character. A character correction of 0dB has therefore been applied in the determination of the receptor Rating levels ( $L_{Ar,Tr}$ ).

**Table 7-1 – Assessment of Noise Levels from Proposed Permit Variation**

Ref.	Name	Hepworth Measurement Location	Prevailing Sound Level (No Variation) (dB $L_{A90}$ ) [A]	Permit Variation (Only) Noise Level [B], dB $L_{Ar,Tr}$	Difference [B-A]
9	Fowey Bungalow	3	36	26.6	-9.4
12	Owls Gate, Treworra	B	33	23.9	-9.1
21	Nettings Park, Davidstow	2	36	30.3	-5.7
29	The Bungalow, Davidstow	5	38	22.5	-15.5
31	Greenwood Cottage, Trewassa	A	45	36.8	-8.2
39	Treworra Barton	B	33	22.5	-10.5
40	Notties Park	4	42	25.9	-16.1
42	St Kitts Farn	1	34	27.6	-6.4

- 7.1.4. It is acknowledged that permit noise assessment guidance as summarised in Section 3 suggests that assessment should include assessment of receptor Rating levels both ‘without’ and ‘with’ the proposed Permit Variation. However, in this case it can be seen from **Table 7-1** above that predicted noise levels from the proposed Permit Variation fall between 6 and 16dB below the prevailing  $L_{A90}$  sound levels at the closest receptors to the creamery and the WPF. This confirms that levels generated by the proposed Permit Variation are unlikely to give rise to any observable change in the currently prevailing noise levels.
- 7.1.5. The currently prevailing levels of noise from the facility are subject to an annual noise monitoring and assessment programme, undertaken by Hepworth Acoustics. The associated assessment reporting is provided to the Environment Agency and includes the results of both individual source noise measurements for all key sources across the site, assessment in accordance with BS4142,



and identification of noise mitigation measures to ensure compliance with the principles of Best Available Techniques (BAT).

- 7.1.6. The results of this assessment confirm that that noise from the proposed Permit Variation has no significant bearing on noise emissions from the site or therefore the noise assessment work previously undertaken in full accordance with BS4142 and submitted to the Environment Agency. Therefore, **noise need not be considered a determining factor in granting the permit variation.**

## 8 MITIGATION

---

- 8.1.1. The completed assessment has identified that sound levels from the proposed Permit Variation fall significantly below those that prevail from the existing facility. No noise mitigation measures focussed on the elements falling under the permit variation are therefore warranted.
- 8.1.2. Dairy Crest will continue with its annual noise monitoring and assessment programme that is designed to monitor and reduce noise levels from the existing facility and ensure that compliance with the principles of BAT is retained.

## 9 CONCLUSIONS

---

- 9.1.1. This report has presented the results of a detailed noise assessment undertaken by WSP, following appointment by Saputo Dairy UK, to support an application to vary existing Environmental Permit reference EPR/BN6137IK/V009, issued 10 November 2020.
- 9.1.2. The Permit is pertinent to operations at the Davidstow Dairy facility. The dairy is operated by Dairy Crest Limited (“Dairy Crest”). Saputo Dairy UK (SDUK, or ‘Saputo’) is a trading name used for Dairy Crest following its acquisition of the company in 2019. Dairy Crest remains the legal trading entity for the company and, therefore, it remains the named operator on the Environmental Permit.
- 9.1.3. The application to vary the existing Permit is being made to cover a number of changes (some proposed and some completed) to increase cheese and galacto-oligosaccharide (GOS) production capacity as well as making improvements to the management of wastewater at the site. The existing facility comprises a creamery with an associated, but geographically separate, water processing facility (WPF).
- 9.1.4. The completed assessment has considered the potential noise impact associated with the proposed Permit Variation and has been undertaken with reference to Environment Agency guidance for dealing with noise ‘emissions’ under the Environmental Permitting regime, namely the following:
- *‘Noise and vibration management: Environmental Permits. How UK environment agencies assess noise, legal requirements for managing noise, noise impact assessment and noise management plans. This replaces H3 guidance’, the latest version of which is dated 31 January 2022; and*
  - *‘Noise impact assessments involving calculations or modelling: Information you must submit to the Environment Agency in a noise impact assessment that uses computer modelling or spreadsheet calculation’, the latest version of which is dated 06 November 2019.*
- 9.1.5. In line with the requirements of the above guidance, the noise assessment has been undertaken with reference to BS4142: 2014+A1: 2019: *Method for rating and assessing industrial and commercial sound* (BS4142).
- 9.1.6. The completed assessment has been undertaken drawing on the results of extensive baseline noise survey work that has previously been completed for both the creamery and the WPF (undertaken and reported by Hepworth Acoustics), as well as manufacturers’ plant noise emission data and supplementary on-site noise measurements undertaken by WSP. The previous Hepworth Acoustics noise surveys (undertaken in 2018, 2020 and 2021) and associated reporting included the results of extensive noise monitoring undertaken at locations selected as representative of local noise sensitive receptors, as well as source noise measurements of equipment and operations across the creamery and the WPF. These reports also include assessment of current noise emissions from the site in accordance with BS4142, and assessment of noise mitigation measures for the existing facility.
- 9.1.7. A detailed noise model for the site and surrounding area has been prepared to facilitate noise level predictions for the site changes associated with the proposed Permit Variation. The noise model was prepared in the CadnaA® PC-based noise modelling suite. This report provides details of the adopted approach, including how each source has been modelled and the source noise emission data applied.

- 9.1.8. The noise model has been used to calculate the resulting operational noise levels from the suite of changes covered by the proposed Permit Variation, once they are all completed. The modelled noise levels have been assessed by comparing them against the currently prevailing sound levels at local noise sensitive receptors, determined from the results of previously reported measurement data.
- 9.1.9. It has been identified that operational noise levels from the proposed Permit Variation will be substantially below the prevailing  $L_{A90}$  sound levels at the closest receptors to the creamery and the WPF. Differences have been identified in the range of -6dB to -16dB. This confirms that levels generated by the proposed Permit Variation are unlikely to give rise to any observable change in the currently prevailing noise levels.
- 9.1.10. No noise mitigation measures focussed on the elements falling under the Permit Variation are therefore warranted, but Dairy Crest will continue with its annual noise monitoring and assessment programme that is designed to monitor and control noise levels from the existing facility and ensure that compliance with the principles of BAT is retained.
- 9.1.11. In summary, this report has identified that noise is not a factor that requires further consideration in the determination of the proposed Permit Variation.

# Appendix A

GLOSSARY OF ACOUSTIC  
TERMINOLOGY

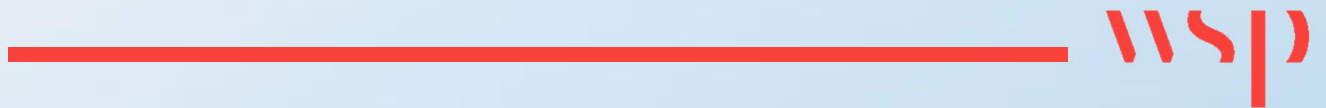



## NOISE

Noise is defined as unwanted sound. Human ears are able to respond to sound in the frequency range 20 Hz (deep bass) to 20,000 Hz (high treble) and over the audible range of 0 dB (the threshold of perception) to 140 dB (the threshold of pain). The ear does not respond equally to different frequencies of the same magnitude, but is more responsive to mid-frequencies than to lower or higher frequencies. To quantify noise in a manner that approximates the response of the human ear, a weighting mechanism is used. This reduces the importance of lower and higher frequencies, in a similar manner to the human ear.

Furthermore, the perception of noise may be determined by a number of other factors, which may not necessarily be acoustic. In general, the impact of noise depends upon its level, the margin by which it exceeds the background level, its character and its variation over a given period of time. In some cases, the time of day and other acoustic features such as tonality or impulsiveness may be important, as may the disposition of the affected individual. Any assessment of noise should give due consideration to all of these factors when assessing the significance of a noise source.

The most widely used weighting mechanism that best corresponds to the response of the human ear is the 'A'-weighting scale. This is widely used for environmental noise measurement, and the levels are denoted as dB(A) or  $L_{Aeq}$ ,  $L_{A90}$  etc., according to the parameter being measured.

The decibel scale is logarithmic rather than linear, and hence a 3 dB increase in sound level represents a doubling of the sound energy present. Judgement of sound is subjective, but as a general guide a 10 dB(A) increase can be taken to represent a doubling of loudness, whilst an increase in the order of 3 dB(A) is generally regarded as the minimum difference needed to perceive a change under normal listening conditions.

An indication of the range of sound levels commonly found in the environment is given in the following table.

**Table A-1 – Range of Typical Sound Levels Found in the Environment**

Sound Level	Location
0 dB(A)	Threshold of hearing
20 to 30 dB(A)	Quiet bedroom at night
30 to 40 dB(A)	Living room during the day
40 to 50 dB(A)	Typical office
50 to 60 dB(A)	Inside a car
60 to 70 dB(A)	Typical high street
70 to 90 dB(A)	Inside factory
100 to 110 dB(A)	Burglar alarm at 1m away
110 to 130 dB(A)	Jet aircraft on take off

140 dB(A)	Threshold of pain
-----------	-------------------

**Table A-2 – Terminology Relating to Noise and Sound**

<b>Term</b>	<b>Description</b>
Sound Pressure	Sound, or sound pressure, is a fluctuation in air pressure over the static ambient pressure.
Sound Pressure Level (Sound Level)	The sound level is the sound pressure relative to a standard reference pressure of 20µPa (20x10 <sup>-6</sup> Pascals) on a decibel scale.
Decibel (dB)	A scale for comparing the ratios of two quantities, including sound pressure and sound power. The difference in level between two sounds $s_1$ and $s_2$ is given by $20 \log_{10} (s_1 / s_2)$ . The decibel can also be used to measure absolute quantities by specifying a reference value that fixes one point on the scale. For sound pressure, the reference value is 20µPa.
A-weighting, dB(A)	The unit of sound level, weighted according to the A-scale, which takes into account the increased sensitivity of the human ear at some frequencies.
Ambient Sound	The totally encompassing sound in a given situation at a given time, usually composed of sound from many sources near and far. The ambient sound comprises the residual sound and the specific sound when present. <i>The ambient sound level, <math>L_a</math> is defined as an <math>L_{Aeq,T}</math> level</i>
Residual Sound	The ambient sound remaining at the assessment location when the specific sound source is suppressed to such a degree that it does not contribute to the ambient sound <i>The residual sound level, <math>L_r</math> is defined as an <math>L_{Aeq,T}</math> level</i>
Background Sound $L_{A90,T}$	A-weighted sound pressure level that is exceeded by the residual sound at the assessment location for 90% of a given time interval, $T$ , measured using time weighting $F$ and quoted to the nearest whole number of decibels
Specific Sound	Equivalent continuous A-weighted sound pressure level produced by the specific sound source at the assessment location over a given reference time interval, $T_r$ <i>The specific sound level, <math>L_s</math> is defined as an <math>L_{Aeq,T}</math> level</i>
Rating Level	The specific sound level plus any adjustment for the characteristic features of the sound
$L_{eq,T}$	A sound level index called the equivalent continuous sound level over the time period $T$ . This is the level of a notional steady sound that would contain the same amount of sound energy as the actual, possibly fluctuating, sound that was recorded.
$L_{max,T}$	A sound level index defined as the maximum sound level during the period $T$ . $L_{max}$ is sometimes used for the assessment of occasional loud noises, which may have little effect on the overall $L_{eq}$ sound level but will still affect the sound environment. Unless described otherwise, it is measured using the 'fast' sound level meter response.



Free-Field	Far from the presence of sound reflecting objects (except the ground), usually taken to mean at least 3.5m.
Façade	At a distance of 1m in front of a large sound reflecting object such as a building façade.
Octave Band	A range of frequencies whose upper limit is twice the frequency of the lower limit.

# Appendix B

FIGURES

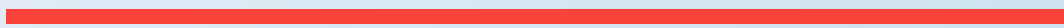
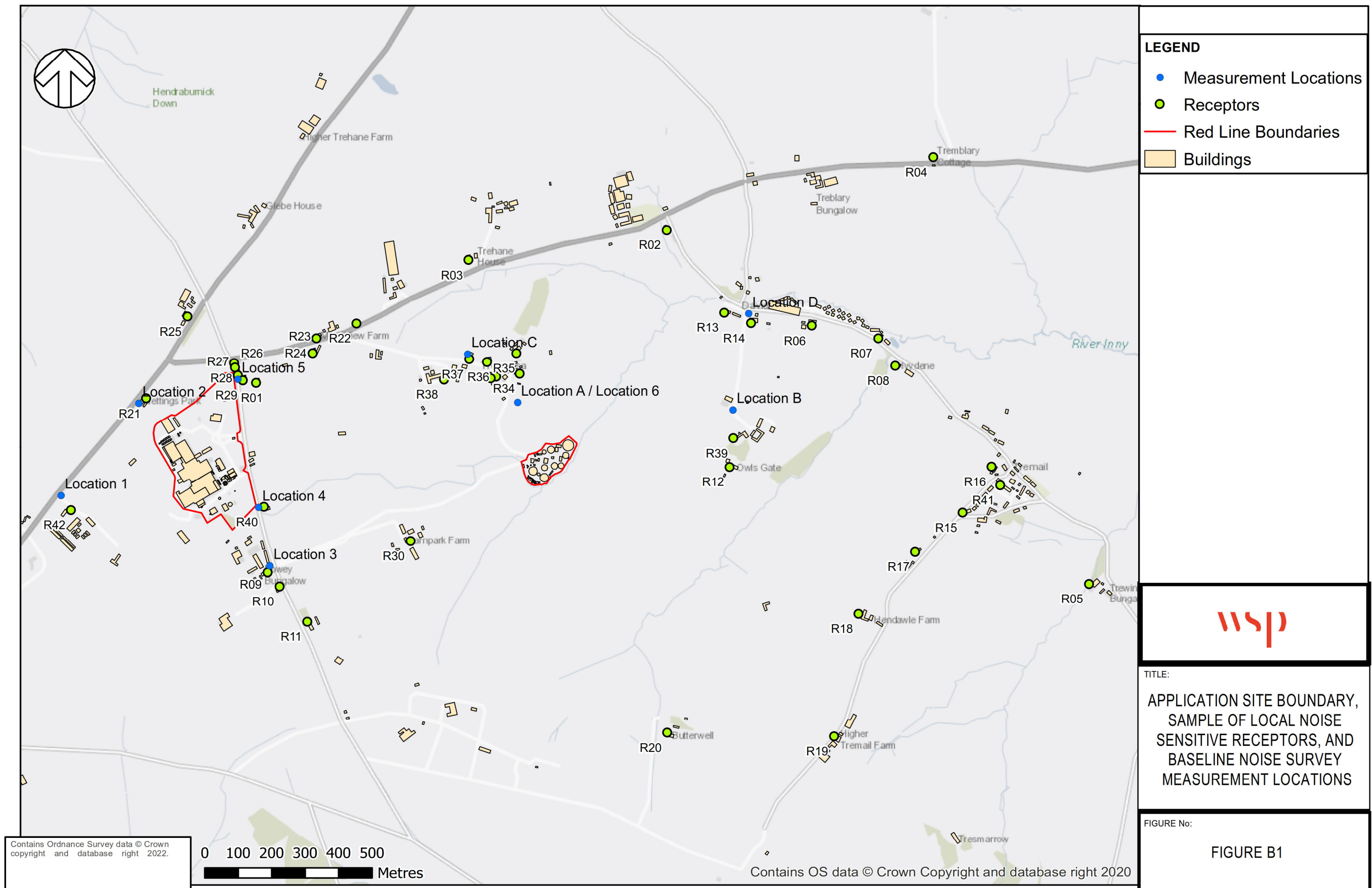

Figure B1 - Application Site Boundary, Sample of Local Noise Sensitive Receptors, and Baseline Noise Survey Measurement Locations



# Appendix C

MANUFACTURERS PLANT NOISE  
EMISSION DATA





# SPX WAUKESHA CHERRY-BURRELL S SERIES FIXED MOUNTED MIXER



INSTRUCTION MANUAL

## S-Series Mixer

SANITARY STAINLESS STEEL PORTABLE AND FIXED MOUNT MIXERS

FORM NO.: 95-05001 REVISION: 02/2012

READ AND UNDERSTAND THIS MANUAL PRIOR TO OPERATING OR SERVICING THIS PRODUCT.



**> Waukesha Cherry-Burrell®**

- d. Thoroughly REVIEW and ADHERE TO the mixer operating instructions starting on page 11.
  - e. Ensure the mixer output shaft rotates freely by hand.
  - f. Ensure all personnel and equipment are clear of rotating parts.
  - g. Ensure all external connections (electrical, hydraulic, pneumatic, etc.) have been completed in accordance with all applicable codes and regulations.
14. DO NOT enter the mixing vessel UNLESS:
- a. The mixer power supply is locked out (follow Item number 5, above).
  - b. The impeller shaft is firmly attached to the mixer drive or the shaft is supported securely from below.
  - c. You have followed applicable confined space regulations.
15. WARNING: Eye protection must be worn at all times while servicing this mixer. Failure to follow this instruction may result in severe injury or death.
16. WARNING: Never attempt to clean or service the mixer, or any part of it, while the mixer is running, or while it is connected to a power source. Always turn the mixer off and disconnect the power before cleaning or servicing.
17. CAUTION: When repairing the mixer, or replacing parts, use factory authorized parts and procedures. Failure to do so may result in damage to the mixer or injury to the user.

### CE Compliance

If the mixer nameplate has a CE marking on it, then the equipment furnished conforms to the following directives:

Machinery Directive: 2006/42/EC  
 Electro-Magnetic Compatibility: 2004/108/EC  
 Low Voltage Directive: 2006/95/EC  
 Noise: 2000/14/EC



**CAUTION:** When applicable specific markings required by Pressure Equipment Directive 97/23/EC (PED) and/or Equipment for Use in Potential Explosive Atmospheres Directive 94/9/EC (ATEX) will be indicated on supporting nameplates. If there is any doubt relating to the intended use of this equipment please contact SPX before installation and operation.

Any CE marking and/or associated documentation applies to the mixer only. This has been supplied on the basis that the mixer is a unique system. When the mixer is installed, it becomes an integral part of a larger system which is not within the scope of supply and CE marking is the responsibility of others.

### Noise Levels

Sound Pressure Levels:  
 Portable Series: ECL, EV - maximum 80 dBA @ 1 meter.  
 Heavy Series: S10, 70/80, 500/600 - maximum 85 dBA @ 1 meter.



- 11.8 **CAUTION**  
Repeated trial starts can overheat the motor (particularly for across-the-line starting). If repeated trial starts are made, allow sufficient time between trials to permit heat to dissipate from the windings or rotor to prevent overheating. Starting currents are several times running currents, and heating varies as the square of the current. Do not exceed 12 starts per hour.
- 11.9 **WARNING**  
The frames and other metal exteriors of motors should be grounded to limit their potential to ground in the event of accidental connection or contact between live electrical parts and the metal exteriors. All motors should be grounded through the conduit box.
- 11.10 **WARNING**  
Before starting motor, remove all unused shaft keys and loose rotating parts to prevent them from flying off.
- 11.11 Start motor and operate at minimum load prior to filling the tank or basin. Look for any unusual condition. The motor should run smoothly with little noise. If the motor should fail to start and produces a decided hum, it may be that the load is too great for the motor or that it has been connected improperly. Shut down immediately and investigate for trouble.

**Section 12 - Motor Maintenance and Storage**

- Electric motors or other prime movers are not prepared by WCB for indoor storage beyond 12 months in a dry ambient atmosphere with controlled temperatures, or 6 months in a dry ambient atmosphere with no temperature control. **OUTDOOR STORAGE OF ELECTRIC MOTORS IS NOT RECOMMENDED BY ANY MOTOR MANUFACTURER.** For information on storage periods beyond those shown, consult WCB.
- 12.1 To insure continued reliable operation of electric motors, the following basic rule applies: **Keep the motor clean and dry.** Motors should be inspected, and output shaft rotated, at a minimum of 6 month intervals with increased frequency as needed depending upon the type of motor and the service.
  - 12.2 Terminal connections and assembly hardware may loosen from vibration during service and should be tightened.
  - 12.3 Insulation resistance should be checked at operative temperature and humidity conditions to determine possible deterioration of insulation due to excessive moisture or extremes in operating environment. If wide variations are detected, motors should be reconditioned.
  - 12.4 Lubrication  
The ball bearing has deep grooved, double shielded sealed bearings with sufficient lubricant packed into the bearings by the manufacturer for "life lubrication". The initial lubricant is supplemented by a supply packed into larger reservoirs in the end shield at time of assembly. No grease fittings are provided, as the initial lubrication is adequate for up to 10 years of operation under normal conditions.



## SPX LIGHTNIN XDQ-117 TOP MIXERS

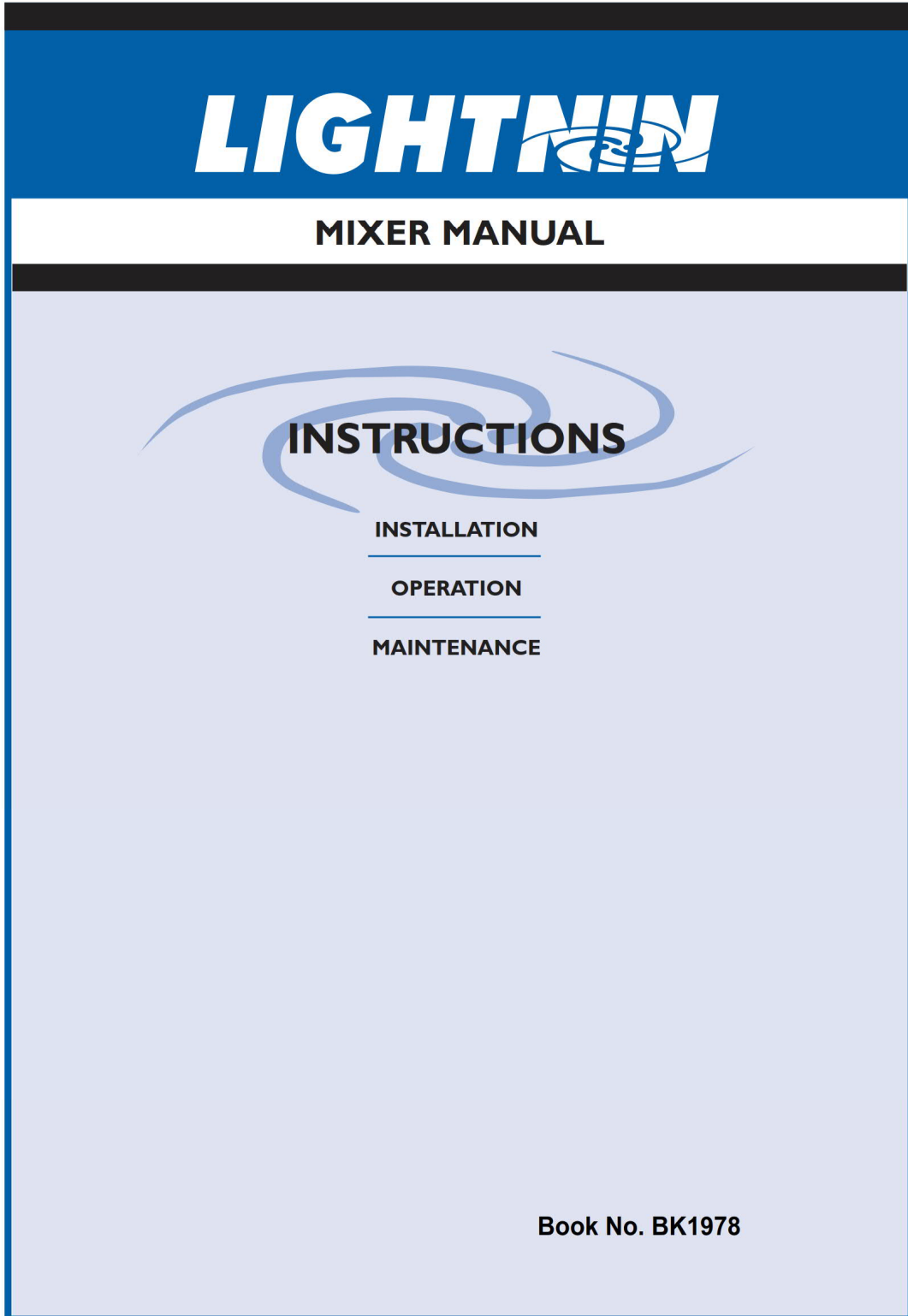

**CERTIFIED DIMENSION DRAWING FOR  
LIGHTNIN XDQ AND XJQ SERIES MIXERS**

**Vertical On-Center Mounting**  
ALL DIMENSIONS IN INCHES

**DRAWING IT-1985**  
ISSUED - 3/15/83  
REVISED - 2/26/01

TANK MAY BE  
ROUND, SQUARE  
OR RECTANGULAR

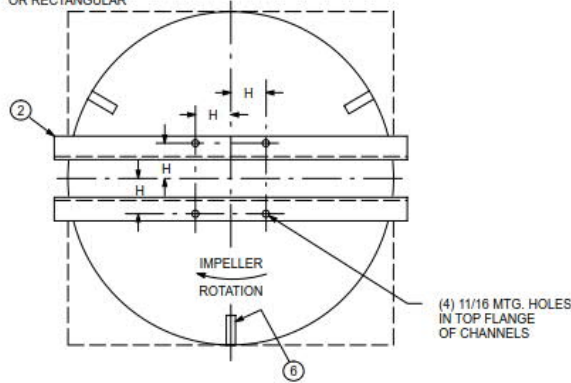

NOTES:

- ① REFER TO ORDER SPECIFICATION SHEET FOR:  
A. MODEL NUMBER AND MOTOR HORSEPOWER.  
B. SHAFT DIAMETER AND FULL LENGTH.  
C. SHAFT CONNECTION - STANDARD CHUCK OR ALTERNATE COUPLING CONSTRUCTION.  
D. QUANTITY AND SIZE OF IMPELLERS.  
E. IF LOWER IMPELLER IS EQUIPPED WITH STABILIZER.
- ② MIXER SUPPORT CHANNEL SIZE (NOT FURNISHED BY "LIGHTNIN"):  
TANKS UP TO AND INCLUDING 8 FEET - 4" X 7.25#  
TANKS OVER 8 FEET - 6" X 8.2#
- ③ MIXER WEIGHT CAN VARY WITH MOTOR CHARACTERISTICS, SHAFT AND IMPELLER SELECTION.
- ④ DIMENSION "A" IS MAXIMUM. CAN VARY SLIGHTLY DEPENDING ON MOTOR ENCLOSURE.
- ⑤ CONDUIT BOX NOT INCLUDED WITH EXPLOSION PROOF MOTOR.
- ⑥ EQUISPACED TANK BAFFLES NOT FURNISHED BY "LIGHTNIN". SEE SPECIFICATION SHEET FOR BAFFLE DIMENSIONAL DATA.

MINIMUM DIAMETER OPENING REQUIRED TO PASS IMPELLER WHEN DETACHED FROM SHAFT			
IMPELLER DIA.	MINIMUM OPENING (IN.)	IMPELLER DIA.	MINIMUM OPENING (IN.)
2.5	2	10.0	7-3/4
3.4	2-5/8	11.2	8-3/4
3.8	3	11.8	9-1/4
4.5	3-1/2	12.8	10
5.2	4	13.6	10-5/8
5.9	4-5/8	15.1	11-3/4
6.3	4-7/8	15.6	12-1/4
6.8	5-1/4	17.0	13-1/4
7.6	6	19.0	15

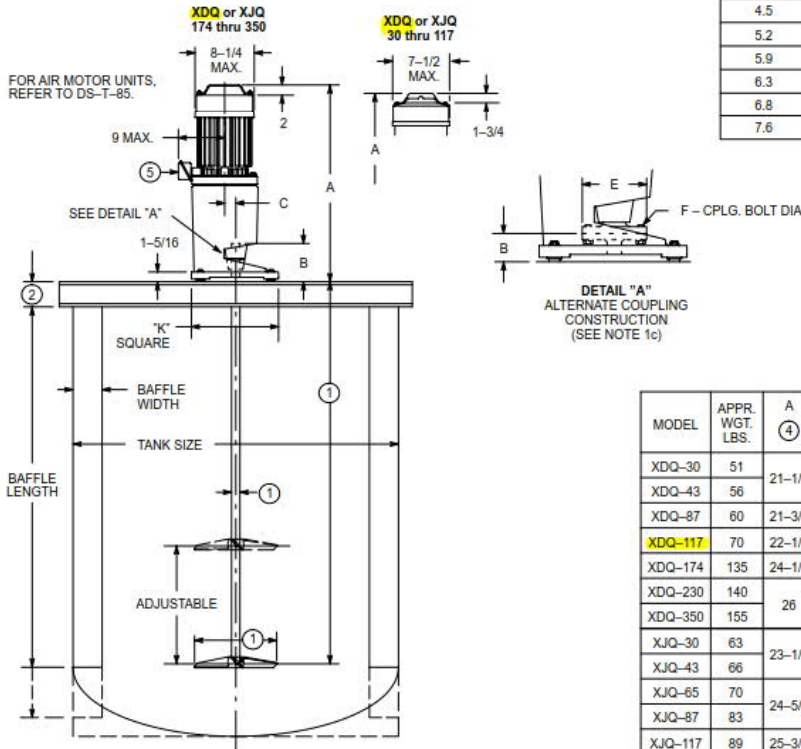

DETAIL "A"  
ALTERNATE COUPLING  
CONSTRUCTION  
(SEE NOTE 1c)

MODEL	APPR. WGT. LBS.	A ④	B		C	E	F	H	K
			WITH CHUCK	WITH CPLG.					
XDQ-30	51	21-1/2	6-1/2	3-1/8	0	3-7/8	3/8	4	10
XDQ-43	56	21-3/4							
XDQ-87	60	21-3/4							
<b>XDQ-117</b>	70	22-1/2	6-3/4	3-1/8	0	4-3/4	1/2	5-1/2	13
XDQ-174	135	24-1/4							
XDQ-230	140	26							
XDQ-350	155	26	6-3/8	2-3/4	1-3/8	3-7/8	3/8	4	10
XJQ-30	63	23-1/4							
XJQ-43	66	23-1/4							
XJQ-65	70	24-5/8	7	2-3/8	1-5/8	4-3/4	1/2	4-1/2	11
XJQ-87	83	25-3/8							
XJQ-117	89	25-3/8							
XJQ-174	155	28-3/4	6-3/4	3	1-7/8	4-3/4	1/2	5-1/2	13
XJQ-230	200	30-1/2							
XJQ-350	225	30-1/2							

CERTIFICATION: This drawing, when used in conjunction with the attached specification sheet for LIGHTNIN Order \_\_\_\_\_ represents certified dimensions.

© LIGHTNIN  
2001

**LIGHTNIN**

---

**CE COMPLIANCE**

If mixer nameplate has a CE marking on it, then the equipment furnished conforms to the following directives:

- 98/37/EC Machinery Directive
- 89/336/EEC Electro-Magnetic Compatibility
- 73/23/EEC Low Voltage

Any CE marking and/or associated documentation applies to the mixer only. This has been supplied on the basis that the mixer is a unique system. When the mixer is installed, it becomes an integral part of a larger system which is not within the scope of supply and CE marking is the responsibility of others.



**CAUTION:** CE Compliance does not imply that the mixer satisfies PED (Pressure Equipment 97/23/EC) or ATEX (Potential Explosive Atmospheres 94/9/EC) unless marking is clearly shown on mixer.

**NOISE LEVELS**

**SOUND PRESSURE LEVELS**

Portable Series: ECL, EV – maximum 80 DbA @ 1 meter

Heavy Series: S10, 70/80, 500/600 – maximum 85 DbA @ 1 meter

THIS PRODUCT MAY BE COVERED BY ONE OR MORE OF THE FOLLOWING U. S. PATENTS:

5006283	5046245	5118199	5152934	5152606	5203630
5344235	5364184	5368390	5378062	5427450	5454986
5470152	5478149	5480228	5501523	5511881	5560709
5568975	5568985	5655780	5720286	5746536	5758965
5779359	5842377	5925293	5951162	5972661	5988604
6089748	6109449	6142458	6158722	6250797	6299776
6334705	6386753	6457853	6634784	6715913	6742923
6746147	6789314	6796707	6796770	6808306	6843612
6860474	6877750	6935771	6986507	6997444	7001063
	7056095	7168641	7168848	7168849	

---

REVISION G	DATE 5-9-86 REVISED 05-14-07	<b>LIGHTNIN</b> <sup>®</sup> MIXERS AND AERATORS	© LIGHTNIN 2007	INST. NO. IT-2144 PAGE 2 OF 2
---------------	---------------------------------	---	--------------------	----------------------------------

---

# Appendix D

NOISE CONTOUR PLOT

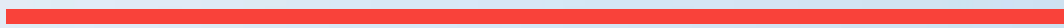
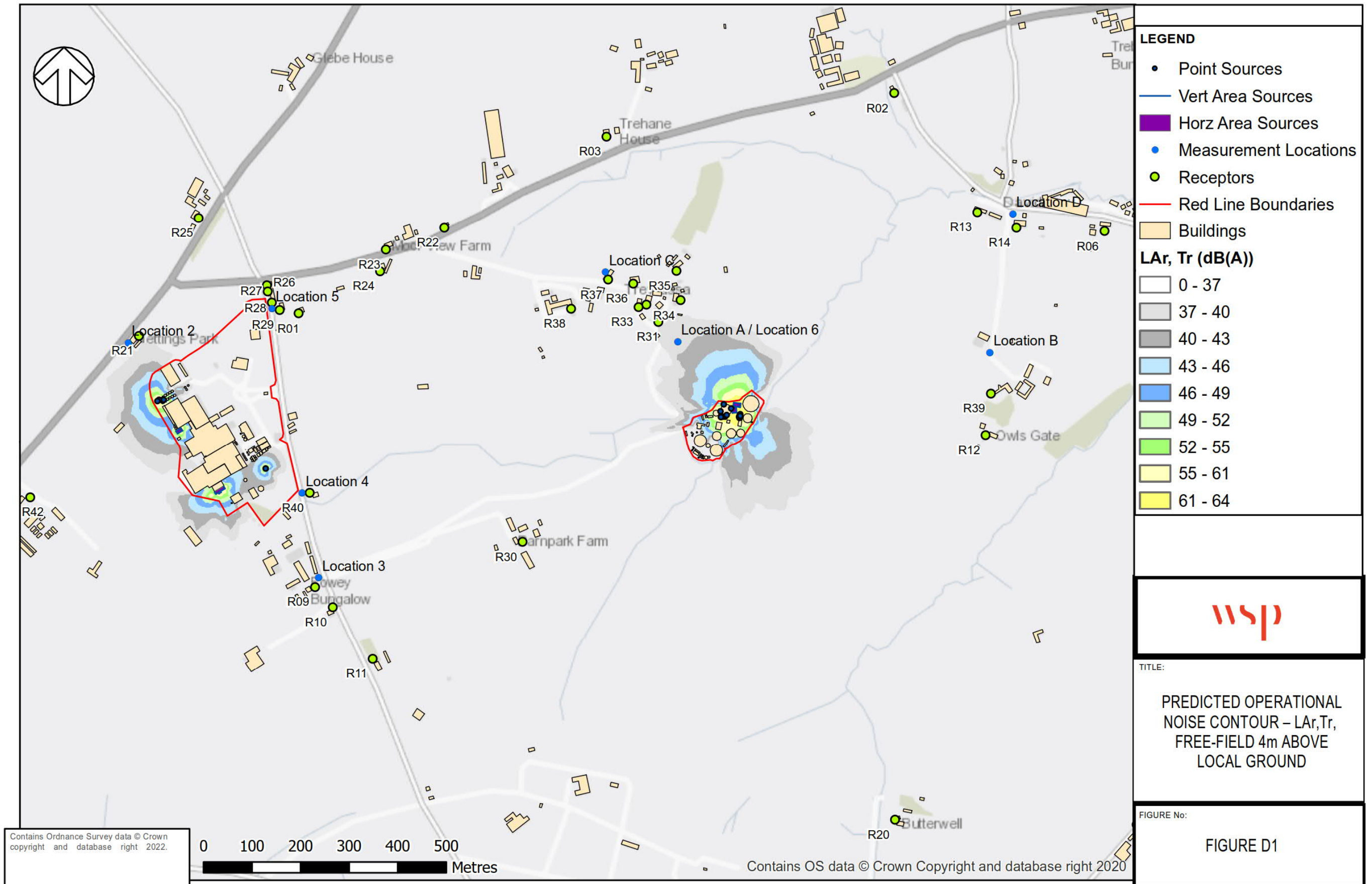

Figure D1 – Predicted Operational Noise Contour – dB L<sub>Ar,Tr</sub>, Free-field 4m above local ground



# Appendix E

LIMITATIONS





## LIMITATIONS TO THIS REPORT

This report has been prepared for the titled project or named part thereof and should not be used in whole or part and relied upon for any other project without the written authorisation of WSP UK Ltd. WSP UK Ltd accept no responsibility or liability for the consequences of this document if it is used for a purpose other than that for which it was commissioned. Persons wishing to use or rely upon this report for other purposes must seek written authority to do so from the owner of this report and/or WSP UK Ltd and agree to indemnify WSP UK Ltd for any and all loss or damage resulting therefrom. WSP UK Ltd accepts no responsibility or liability for this document to any other party other than the person by whom it was commissioned. The findings and opinions expressed are relevant to the dates of the site works and should not be relied upon to represent conditions at substantially later dates. Opinions included therein are based on information gathered during the study and from our experience. If additional information becomes available which may affect our comments, conclusions or recommendations WSP UK Ltd reserve the right to review the information, reassess any new potential concerns and modify our opinions accordingly





8 First Street  
Manchester  
M15 4RP

[wsp.com](http://wsp.com)

CONFIDENTIAL