



## **Enterprise Skip Hire Ltd**

**Chiltern View Nursery  
Wendover Rd, Stoke Mandeville**

**EPR/DB3904US**

**Operational Plan (OP)**

**Document Ref: 233036/OP**

**August 2024**

**AA Environmental Limited**

Units 4 to 8 Cholswell Court

Shippon

Abingdon

OX13 6HX

**T 01235 536042**

**F 01235 532849**

[info@aae-ltd.co.uk](mailto:info@aae-ltd.co.uk)

[www.aae-ltd.co.uk](http://www.aae-ltd.co.uk)

---

**REPORT FOR:**

Enterprise Waste Management  
Wendover Rd  
Stoke Mandeville  
Aylesbury  
HP22 5GX

**Enterprise Waste Management  
Wendover Rd  
Stoke Mandeville  
Aylesbury  
HP22 5GX**

---

|                   |                           |
|-------------------|---------------------------|
| <b>Issue Date</b> | <b>Document Reference</b> |
| August 2024       | 233036/OP                 |

---

**Issued By**

.....  
**Emily Ford MSc BSc (Hons)**

**Reviewed By**

.....  
**Ed Brown BSc (Hons) MCIWM**

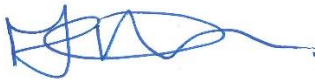
**Approved By**

.....  
**Matthew Lawman MSc BSc (Hons)**

**AA Environmental Limited (Registered Office)**

Unit 4 to 8  
Cholswell Court  
Shippon  
Abingdon  
OX13 6HX

**T** 01235 536042  
**F** 01235 532849  
**E** [info@aae-ltd.co.uk](mailto:info@aae-ltd.co.uk)  
**W** [www.aae-ltd.co.uk](http://www.aae-ltd.co.uk)

Company No. 8474322

**Table of Revisions**

| <b>Issue</b> | <b>Date</b> | <b>Description of Changes</b> |
|--------------|-------------|-------------------------------|
| Revision A   | 30.08.24    | Changes to EWC codes.         |
|              |             |                               |
|              |             |                               |
|              |             |                               |

# Contents

- 1.0 INTRODUCTION**
- 2.0 MANAGEMENT**
- 3.0 WASTE MANAGEMENT OPERATIONS**
- 4.0 POLLUTION PREVENTION & CONTROL**
- 5.0 SITE INFRASTRUCTURE**
- 6.0 ENVIRONMENTAL CONTROL AND MONITORING**
- 7.0 INFORMATION MANAGEMENT**

## **DRAWINGS**

|              |                    |
|--------------|--------------------|
| 233036/D/001 | Site Location Plan |
| 233036/D/002 | Site Receptor Plan |
| 233036/D/004 | Site Layout Plan   |
| 233036/D/005 | Site Drainage Plan |

## **SCHEDULES**

|              |  |
|--------------|--|
| Schedule 1   | Permitted Operations                         |
| Schedule 2.1 | Permitted Waste Types – storage and transfer |
| Schedule 2.2 | Permitted Waste Types – physical treatment   |

## **APPENDICES**

|            |                         |
|------------|-------------------------|
| Appendix A | Interceptor details     |
| Appendix B | CCTV camera details     |
| Appendix C | Site Diary Log Template |

## 1.0 INTRODUCTION

### Overview

- 1.1 This Operational Plan (OP) describes the operation of the site, in line with the standards of the Environment Agency (EA) and activities within EA Guidance<sup>1</sup> and Sector Guidance<sup>2</sup>. The site is a transfer station located on land adjacent to Chiltern View Nursery, Wendover Road, Stoke Mandeville, Aylesbury, HP22 5GX. The site location plan is presented in drawing 233036/D/001. The site receptors are presented in drawing 233036/D/002.
- 1.2 The Operator is Enterprise Skip Hire Ltd. The site operates under a bespoke permit (A16 site) for physical treatment of non-hazardous and inert wastes.
- 1.3 The waste management operations, and limits to operations to be carried out at the site are shown in Schedule 1. Permitted waste types are shown in Schedule 2.1 and 2.2 of the OP.
- 1.4 The annual maximum amount of waste to be accepted at the site is 125,000 tonnes.
- 1.5 The site operations involve treatment and processing of inert and non-hazardous waste streams for onward recovery. Treatment includes manual sorting, trommeling, separation, screening, crushing or compaction of waste.

---

<sup>1</sup> Non-hazardous and inert waste: appropriate measures for permitted facilities, EA website (updated December 2022, accessed 22/02/23)

<sup>2</sup> Sector Guidance Note S5.06: recovery and disposal of hazardous and non-hazardous waste (October 2018)

## 2.0 MANAGEMENT

2.1 The site is operated in accordance with the Operator's site-specific Environmental Management System (EMS).

2.2 The site has specific management plans including, but not limited to, the following:

- Operational Plan (this document);
- Accident Prevention Management Plan (includes contingency measures);
- Fire Prevention Plan;
- Dust Emissions Management Plan;
- Odour Management Plan;
- Pest Management Plan;
- Spill Response Plan;
- Site and Equipment Maintenance Plan; and
- Complaints procedure.

2.3 These plans and other site procedures set out the following:

- Control of operations on the environment;
- Register of Environmental Effects;
- Monitoring of emissions;
- Management of Staff Competence & Training (Roles and Responsibilities);
- Training of all staff on EMP
- Record Keeping;
- Inspections (Daily Record and includes TCM presence);
- Policies;
- Review process of the EMS; and
- Site Closure arrangements.

### **Staffing**

2.4 All staff and operatives have clearly defined roles and responsibilities with specified skills for each post required.

2.5 At all times, there is sufficient staff to manage and operate activities on the site without causing a risk to the environment. Staff employed at the site on a typical shift may include:

- Materials Engineer and/or Technically Competent Manager (TCM) or delegate;
- Sales and office workers, including weighbridge operative;
- 5 x Plant operatives; and
- Site Manager.

2.6 In accordance with Environment Agency guidance the site is supervised by the TCM, in addition to at least one member of staff who is fully conversant with the requirements of the Permit and Operational Plan regarding, in particular, the following:

- Waste acceptance and control procedures;
- Operational controls and environmental monitoring;
- Maintenance;
- Record-keeping;
- Accident/incident action plans; and
- Notifications to the Environment Agency.

2.7 The TCM is on site for greater than 20% of the operation of the facility.

2.8 Technical staff demonstrate continuing competence by passing periodic assessment. Personal training records will be kept, to provide evidence.

- 2.9 All contractors are trained about the relevant working controls and legal responsibilities relating to their areas of works.
- 2.10 The Site Manager only authorises for works to be undertaken once relevant legal requirements and a site-specific risk assessment has been completed.

**Working Hours**

- 2.11 The site operates in line with standard operating hours as presented in Table 1.

| <b>Table 1. Operating Hours</b> |                                   |
|---------------------------------|-----------------------------------|
| Monday to Friday                | 07:00 to 17:00                    |
| Saturday                        | 08:00 to 13:00                    |
| Sunday and Public Holidays      | No vehicle movements or operation |

- 2.12 Working hours will be in accordance with the current planning permission.

**3.0 WASTE MANAGEMENT OPERATIONS**

**Operations and activities**

- 3.1 The operation of the site will consist of the incoming non-hazardous wastes being processed and treated (physical treatment by mechanical and manual sorting) within Building 1 and A; and processing inert C&D waste in Building 2. Storage of segregated waste types will be in Building 2 and B. There is bulking and loading of waste and recovered materials internally and within the external area.
- 3.2 All incoming non-hazardous wastes are received and deposited within the main waste acceptance area (Building 1) as shown on drawing 233036/D/004. Initial manual and mechanical segregation of oversize materials including wood, metals, plastics are undertaken. Any plasterboard identified is segregated and kept in a bay in Building B. Wastes are deposited within the ‘feedstock’ area in Building A. Non-hazardous waste is treated via segregation using trommels, screens and picking stations. Any shredding of segregated wood will be in Building 1. Recyclable material is recovered and placed in dedicated bays. External treatment operations include screening and crushing of materials to produce aggregate and soils.
- 3.3 The non-hazardous wastes are mechanically and/or manually segregated and loaded on to the processing line (trommel and picking station). The segregated recyclable non-hazardous wastes are moved by to the bulk storage containers in Building 2 prior to being re-used or recycled off site. There may also be internal storage of processed waste streams. The operational site layout is presented on drawing 233036/D/004.

**Waste acceptance control systems and procedures**

- 3.4 Prior to accepting any waste, all waste producers are notified of acceptable and unacceptable wastes to be received at the site. At the pre-acceptance stage, the Operator will consider and gather the following information:
- The source and nature of the waste;
  - Potential risks to process safety, occupational safety and the environment;
  - Knowledge of the previous waste holder;
  - Ensure satisfactory information that the waste has been assessed and classified by the waste producer in line with WM3;
  - Details of the waste producer including their organization name, address and contact details;
  - Description of the waste;
  - The EWC code;
  - The source of the waste;
  - Information on the nature and variability of the production process;
  - History of the producing site;
  - Wastes physical form/composition;

- Description of the waste's odour and odour potential;
  - Estimated quantity to expect in each load and over a year;
  - For mirror entries, the Operator will keep evidence of any assessment and assignment of mirror entry code; and
  - Sampling certificates of analysis (if undertaken).
- 3.5 All wastes must be assessed and classified in line with WM3 guidance. This forms part of the Terms and Conditions (T&Cs) which are sent to all waste producers. The T&C's are on: <https://www.enterprise-skiphire.co.uk/terms-conditions/>. The site only receives those wastes specified in Schedule 2.1 and 2.2. Non-conforming wastes within skips within the T&Cs include, but not limited to:
- No plasterboard in mixed loads. Waste producers must discuss plasterboard disposal options with the Operator, including the option to have a separate collection/container for plasterboard;
  - No hazardous wastes including hazardous wood as per WRA guidance; and
  - Domestic upholstery.
- 3.6 Waste entering the site is visually inspected initially at the weighbridge, by CCTV into back of truck, at the site offices and associated duty of care paperwork checked; including details of the waste carrier registration, completion of signatures and dates. Drivers are instructed by staff where to place the contents of the delivery. All wastes deposited at the site are within the main waste acceptance area in Building 1 as shown in drawing 233036/D/004. Waste is inspected at ground level by plant operatives banksman in the main reception area.
- 3.7 The Waste Transfer Note is taken (physically or digitally) from the carrier, checked to ensure it is fully completed with the correct data and the material conforms to the pre-acceptance information. If the Operative is satisfied with the details provided, the Carrier is directed to the relevant processing area. Vehicular unloading is supervised by a trained operative. During placement of the waste, the waste material is further inspected to check its contents are consistent with the description provided on the Duty of Care note. If there is any uncertainty regarding the waste type against the expected characterisation as set out in the pre-acceptance information and/or Duty of Care note, the material and/or the vehicle is isolated/quarantined until the assessment can be concluded. Rejected loads are recorded in the Site Diary.
- 3.8 For each delivery, the site foreman ensures the Waste Transfer Note (hard copy or electronic) is properly filled in and signed off, and records details of the waste delivery which includes at least the following:
- Date and time of delivery;
  - SIC code;
  - Container type;
  - Vehicle details (registration mark);
  - Written description, EWC code, origin and quantity of the waste;
  - Waste producer and waste transferor details / signatures; and
  - Waste transfer note number
- 3.9 Wastes are continuously visually inspected by personnel working within the operational areas during the waste processing. Any wrongly described waste subsequently identified is recorded in the site diary and advice sought from the TCM and/or Environment Agency, if appropriate.
- Storage over shutdown periods and security**
- 3.10 Loaded vehicles are turned away when the site is not operational. In the event that a vehicle cannot be turned away, it is placed adjacent to the quarantined section.
- Housekeeping**
- 3.11 As determined necessary through the inspection regime, excessive accumulation of mud and dust on areas of hard standing and haulage roads are cleaned by machine, sweeper or manually cleared.

**Waste rejection and quarantine procedures**

- 3.12 In the event that potentially unacceptable waste is identified during operation it is segregated and taken to the Quarantine Area adjacent to the feedstock/tipping area (shown on 233036/D/004). Unacceptability includes significant odour, dust and/or smouldering wastes. If necessary, further testing is undertaken to determine acceptability. The testing is undertaken by the Operation Manager or delegate.
- 3.13 In the event of non-conforming material is identified, the Producer is notified and if deemed necessary the importation of the waste stream is stopped until acceptability can be confirmed.
- 3.14 In the event that the waste is unacceptable, the Producer is notified to remove the material from site. The details of this incident are recorded in the Site Diary. In the event that a vehicle cannot be immediately turned away (due to the time of day, for example), it is placed adjacent to the quarantined section until practicable to be removed from site. A summary record of the Operator's justification for accepting non-conforming waste will be kept on file.
- 3.15 The site retains copies of the Waste Transfer Notes for all rejected loads for no less than 2 years. In the event the non-conforming waste is hazardous, the Operator will reject the load in line with the EA's rejected loads guidance.
- 3.16 In the event the quarantine area is utilised, the following controls in Table 2 are implemented:

| <b>Table 2 Quarantine Controls</b>  |  |  |
|---|--|--|
| <b>Waste Type</b>   | <b>Waste Processing Controls</b>   | <b>Storage Controls</b>  |
| Containers with dangerous substances, (e.g. diesels, oils and paints) within waste. | Waste treatment to stop in vicinity of the container to be isolated.<br><br>Container and associated product removed and characteristics assessed. | Placed in secure skip with lid. Once classification complete the waste is to be removed from the site for offsite disposal or recovery.  |
| Asbestos  | Waste treatment to stop in vicinity of the identified waste and area isolated.   | Suspected asbestos containing material is double bagged and placed in the asbestos storage area/skip.<br><br>Transferred in enclosed skip for disposal at appropriately licensed waste facility. |
| Large pressurised containers (e.g. gas cylinders).                                  | Container transferred to Quarantine Area.  | Storage in cage.<br><br>Onward transfer for recovery.  |
| Small pressurised containers  | Container transferred to Quarantine Area.  | Storage in cage with lid. Positioned upright, ventilated, secure and well labelled.<br><br>Condition of cylinders to be regularly checked.<br><br>Onward transfer for recovery.                  |
| Plasterboard in mixed loads   | Manual / mechanical segregation in Building 1 and transferred to Building B area for storage only.   | The area is within a building and on a sealed drainage system.<br><br>Onward transfer for recovery.  |



|   |  |   |
|---|--|---|
| Batteries (lithium and/or nickel/cadmium) in mixed loads                  | Principle waste type is accepted on site. Waste treatment to stop in vicinity of the container to be isolated. | If containing POPs and in line with POPs guidance, placed in secure skip with lid.<br><br>Once classification complete the waste is to be removed from the site for offsite disposal or recovery. |
| Waste Electrical and Electronic Equipment (WEEE) or cables in mixed loads | Principle waste type is accepted on site. Waste treatment to stop in vicinity of the container to be isolated. | If containing POPs and in line with POPs guidance, placed in secure skip with lid.<br><br>Once classification complete the waste is to be removed from the site for offsite disposal or recovery. |
| Domestic household upholstery (e.g. sofas)                                | Waste treatment to stop in vicinity of the container to be isolated.   | If containing POPs and in line with POPs guidance, placed in secure skip with lid.<br><br>Once classification complete the waste is to be removed from the site for offsite disposal or recovery. |
| Hazardous wood  | Container transferred to Quarantine Area.  | Storage in container.<br><br>Onward transfer for recovery in line with WRA guidance.  |

3.17 All quarantined waste is typically removed once suitability bulked up and will be stored on site appropriately, as described in Table 2.

#### Waste dispatch procedures

3.18 All waste dispatched from the site are supported by a Waste Transfer Note in accordance with the requirements of the Permit and Duty of Care Requirements. The operator follows guidance presented in Section 34 of the Environmental Protection Act 1990 'Waste Management: The Duty of Care – A Code of Practice'. The site procedures are as follows:

- Wastes sent for onward treatment are segregated from residual waste;
- A full assessment of characteristics is undertaken, in accordance with Waste Classification Technical Guidance WM3, prior to dispatch;
- The waste are given described and documented in a waste transfer note recording its type (including a European Waste Catalogue code), physical form, tonnage and/or volume and how it is contained during transport;
- If the waste is to be transferred by a third party carrier company, the contractor's Waste Carriers Licence is checked. Only licensed carriers are used;
- The waste is loaded into a vehicle with suitable containment and sheeted; and
- Enterprise Skip Hire Ltd maintain records of the transfer for two years for inert/non-hazardous waste.
- Periodic check of transferors details undertaken by TCM.

3.19 There is a site specific Sampling Plan for the trommel fines. Recovered aggregate will be tested in line with the principles of the WRAP Quality Protocol. All waste transferred off site for further recovery is transferred with the descriptions provided in Table 3.

| Table 3 Management of Materials and Waste from Recovery Process |   |  |
|---|---|--|
| Type  | Storage requirements  | Transfer   |
| Metals  | Stored in segregated bay within building or sealed container. | Transfer for onward recovery.<br>Transfer as EWC 19 12 02 or 19 12 03. |

|                        |   |  |
|------------------------|---|--|
| Plastics               | Stored in segregated bay within building or sealed container. | Transfer for onward recovery. Transfer as EWC 19 12 04                             |
| Timber                 | Stored in segregated bay within building or sealed container. | Transfer for onward recovery. Transfer as EWC 19 12 07                             |
| Paper & Cardboard      | Stored in segregated bay within building or sealed container. | Transferred as EWC 20 01 01  |
| Plasterboard           | Stored in segregated bay within building or sealed container. | Transferred as 17 08 02.   |
| Residual waste         | Stored in segregated bay within building or sealed container. | Transferred as EWC 19 12 12 or 19 12 11* (if deemed hazardous).                    |
| Hardcore Aggregate     | Stored in segregated bay internally below belt or externally. | If not deemed recoverable, it is transferred as EWC 19 12 09.                      |
| <50 mm mineral / soils | Stored in segregated bay within building.                     | If not deemed recoverable, it is transferred as EWC 19 12 12 (subject to testing). |

### **Waste quantity measurement systems**

- 3.20 The weight of material received and dispatched is recorded on the weighbridge.
- 3.21 The location of the weighbridge is shown on drawing number 233036/D/004. The weighbridge is maintained in line with the manufacturer's specification. Weekly checks are undertaken to ensure that waste is not accumulating under or in the structure. Any significant accumulated waste is removed.
- 3.22 Any malfunction or damage to the weighbridges is recorded in the site diary and repaired immediately.

## 4.0 POLLUTION PREVENTION AND CONTROL

- 4.1 The entire site area is surfaced by impermeable concrete. The external surfacing drains via a series of falls to the manholes and gullies. The floor of the main buildings (Buildings A & B and Buildings 1 & 2) is under cover and no there is no positive drainage within the buildings. The roof runoff from the buildings is separate to the floor surface water drainage.
- 4.2 All external surface drainage runoff falls towards a silt trap tank and oil separator through a series of gullies to a surface water lagoon in the north west of the site . The site drainage is shown in drawing 233036/D/005.
- 4.3 Foul drainage from the site offices and welfare facilities discharges to the septic tank along the north eastern site boundary. This is collected routinely.
- 4.4 The impermeable concrete will ensure that there is no vertical seepage of surface water from the site area, with all surface waters contained on site. Non-hazardous wastes are stored within a building to prevent connectivity with rainfall.
- 4.5 The inspection of the yard surfacing will include inspection of concrete condition, any sealed joints between concrete slabs. The inspection will occur once the surfacing has been cleaned by road sweeper. The site surfacing inspection, and any maintenance regime, is documented in the daily Site Diary inspection records.

### **Potentially polluting leaks and spillages from vehicles and fixed tanks**

- 4.6 The operator maintains its vehicles, plant and equipment in accordance with relevant legislation. This ensures the manufacturers' schedules are followed and ensures the vehicles, plant and equipment is fit for purpose. The operator trains and authorises its staff to operate the vehicles, plant and equipment to uphold the above.
- 4.7 Plant and machinery are re-fuelled via the onsite fuel tank on a daily basis. COSHH is stored in a secure area as shown on drawing 233036/D/004. The site supervisor ensures only authorised and trained staff carry out activities involving the re-fuelling of plant or associated maintenance.
- 4.8 The maintenance schedule and inspections of the fuel tank and infrastructure by the site manager are recorded in the site diary.
- 4.9 Leaks and spillages from operational equipment and plant on site are controlled by the application of good housekeeping techniques and regular documented maintenance of all plant and equipment. In the event of spillages or leaks in the waste transfer area a supply of absorbent granules/pads and fines-type materials generated from the operations at site is kept and can be applied to the area to prevent potentially polluting materials entering the surface water system which drains to interceptors. All used spill kit will be contained and stored appropriately.
- 4.10 In the event of a significant spillage, the Environment Agency will be notified of the spillage event as soon as possible. All significant spillages and leaks are recorded in the site diary.

## 5.0 SITE INFRASTRUCTURE

### Provision of site identification board

5.1 A site notice board is located at the entrance to the facility. The site identification board is inspected weekly by the manager to ensure it is clearly legible from the site boundary and free from damage or vandalism. The manager records all inspections in the site diary. The site identification board provides the following information:

- Site name and address;
- Permit holder's name;
- Operator name;
- Environmental Permit reference number;
- Emergency contact name and telephone number;
- Confirmation that the site is permitted by the EA;
- The Agency's telephone number (03708 506 506); and
- The days and hours of operation.

5.2 The site identification board are constructed from durable materials and maintained in a clearly legible condition throughout the entire duration of operations at the site.

### Vehicle guidance

5.3 A trained operative (banksman) directs internal traffic and vehicles. The site implements a radio communication system between the banksman, key site staff, and plant operatives to ensure effective on site traffic management and ensure all bulking, treatment and loading of waste occurs within the designated areas with dust suppression.

5.4 In the event the site is experiencing a high number of deliveries, traffic is staggered and the site will notify all incoming lorries to hold back until the site traffic has been alleviated to allow safe operations within the main building.

### Site security, fencing and gates

5.5 The site is accessed and egressed from a private road (part of Chiltern View industrial estate) off Wendover Road, via 3.6 m high padlocked palisade gates. The access point is shown on drawing 233036/D/004. There are also additional barrier gates to prevent vehicular access.

5.6 Within the wider palisade fencing, the site is protected by secure 3.6 m high concrete blocks to deter trespass or bound by the buildings.

5.7 The integrity of the perimeter wall, CCTV and gates is inspected on a daily basis by the Site Manager. Any damage or defects that reduce security at the site will be temporarily repaired as soon as practicably possible and permanently repaired within seven days. Damage to the site walls and gates will be recorded in the site diary, along with any required repairs.

5.8 The site staff are instructed that, in the event of finding evidence of unauthorised access and/or vandalism, the matter must be reported to the Police, TCM and the Site Manager who can then take the appropriate action.

5.9 Security is provided at the offices which controls the only access into and out of the site. Through the use of CCTV, the site operations and security around the yard can be viewed from this point. There are a total of 16 x CCTV cameras, of which 4 are thermal measurement. Details and certificates for the CCTV are provided in Appendix B.

5.10 The industrial estate is manned 24/7 and there is always a security presence on site.

### Lighting

5.11 Security lights are provided internally facing into the operational area. The lights are angled to minimise spillage and are operational throughout night time periods to create a safe and secure working area.

5.12 All lights are regularly inspected with all faults being repaired as and when necessary. All repairs will be recorded in the site diary.

## 6.0 ENVIRONMENTAL CONTROL AND MONITORING

### Management of dust and particular matter

- 6.1 There are no point source emissions of air pollutants. Any releases are fugitive. Operations at the site will be undertaken in accordance with the Dust & Emissions Management Plan (233036/DEMP).

### Management of Mud

- 6.2 The dispersal of dirt and mud originating at the site onto public roads and the surrounding land are controlled. The following operational procedures are implemented to ensure that dirt and mud do not reach the public highways and surrounding land:
- All internal roads are surfaced by concrete surfacing (circa 190 m long); and
  - A high pressure hose and bowser is available in the event that roads or vehicles require washing;
  - Plant and machinery are thoroughly cleaned before leaving the site
  - Mechanical sweeper to be deployed to remediate any mud and debris that has been deposited on to the public highway or metalled access road.
- 6.3 The Manager or nominated deputy regularly inspects the entrance area for evidence of mud and debris that has been trafficked.

### Management of surface water

- 6.4 The site drainage system is shown in drawing 233036/D/005. The clean roof runoff from the offices and buildings discharges to rainwater harvesting tanks, soakaway and/or land drain. This is separate to the wider site surfacing. The surface water from the surfacing is contained within the surface water lagoon via silt trap and oil separator. There is an overflow on the lagoon in the event of overtopping which means that there may be some discharge to surface water during high rainfall conditions. The lagoon water will be inspected weekly. Details of the interceptors are provided in Appendix A.
- 6.5 Non-hazardous wastes (including specified wastes) are stored and treated within Building A and B. There is some initial manual/mechanical segregation of oversize which are then stored within container or within building. The wider surfacing is cleaned and swept on a daily basis.

### Management of groundwater

- 6.6 The site is underlain by bedrock geology of the Gault Formation and Upper Greensand (mudstone, siltstone and sandstone). There are no superficial deposits. The site is not within a Groundwater Source Protection Zone (GSPZ), and the geology is recorded as Unproductive Strata. The site is completely impermeable and the risk to groundwater is assessed to be very low.

### Management of odours

- 6.7 The operator will monitor, control and minimise the emission of odours from the site to prevent releases in such quantities or concentrations that are likely to cause pollution of the environment or harm to human health or serious detriment to the amenity of the locale. Operations at the site will be undertaken in line with the Odour Management Plan (233036/OMP).
- 6.8 It is considered that the majority of waste types (> 90%), and the nature and quantity of waste permitted to be accepted at the site present a low risk of excessive odour generation by the operation of the facility. However, a small percentage (< 20%) of the waste accepted on the site presents a potential odour risk. The greatest risk of odour potential is from the municipal and organic waste streams (primarily EWC: 20 03 01) which are accepted on the site at a limited volume (< 25,000 tonnes per year).
- 6.9 Strong odorous waste streams are not accepted at the site and will be rejected at the weighbridge during inspection against the Duty of Care paperwork. Waste Transfer Notes for the rejected material will be completed by the site manager and returned to the producer. In the event that a particularly odorous waste is accepted it will be isolated and subject to processing to remove the organic content as soon as practicable. The organic material will be removed from site in accordance with the site dispatch procedure.
- 6.10 The prevailing wind is from the south west quadrant. Sniff test monitoring will be undertaken (as set out in Horizontal Guidance H4) around the entire site boundary, as required, or in the event of odour being

reported from the operational staff or receiving a complaint. The monitoring will be undertaken by the Enterprise Skip Hire Ltd TCP or nominated site operative. Monitoring will be recorded in the site diary.

6.11 In the unlikely event of significant odour being detected, the controls set out in the Odour Management Plan will be implemented. This includes:

- the source of odour (i.e down to the relevant producing site if possible) will be determined and the producer notified. No further waste will be accepted for the relevant producing site until the matter has been suitably resolved;
- the odorous waste received will be segregated and transferred to a sealable container in the area, if practicable. The waste will be disposed of in accordance with the waste regulatory regime;
- the misting system used for dust suppression will be adapted to apply a neutralizing agent over any affected wastes.

#### **Management of noise**

6.12 It is considered that the noise levels generated by the site, given the control mechanisms proposed, would be nominal given the nature and hours of the operations. The site is also within an area of high background within a commercial estate and with a railway line to the south west. Regardless of this, a Noise Impact Assessment and Noise Management Plan have been undertaken. All assessment and controls are within those management plan documents.

#### **Management of fire**

6.13 No waste shall be burned at the site. Any occurrence of fire at the facility will be regarded as an emergency and acted upon immediately upon discovery. Operations at the site will be undertaken in accordance with the Fire Prevention Plan (233036/FPP).

#### **Management of pests/birds**

6.14 Wastes with a high organic content are removed from site as soon as practicable. The site supervisor visually monitors for pests throughout the working day. All operations are carried out in line with the Pest Management Plan (233036/PMP).

6.15 In the very unlikely event pests are identified, the Operator will employ a third party contractor to manage pest controls around the site. These are maintained on a recommended basis by the third party contractor. The attendance of the contractor will be recorded in the site diary.

#### **Management of litter and debris**

6.16 The overall risk presented by the escape of litter from the facility is assessed to be low. All loaded vehicles entering or exiting the site are sheeted to prevent litter being released outside the site boundary.

6.17 It is the responsibility of the site staff to constantly monitor the site for signs of escaping materials either from the main buildings, or from vehicles delivering or removing materials to and from the site, particularly during periods of dry and windy weather.

6.18 Any escaping material adhering to perimeter fencing are swept/picked up on a daily basis. Particular emphasis is placed on ensuring that fugitive material is not allowed to escape from the site area.

6.19 A final inspection around the site at the end of the working day and removal of any litter or fugitive material from the perimeter fences, access road and operational area are part of the site staff's daily routine.

6.20 Records of inspections or remedial actions are made in the site diary.

6.21 An excessive spillage of materials anywhere within the site or on the adjacent highway will be dealt with at the end of each day by sweeping of the surface and litter picking if required. Such a spillage and the action taken will be recorded in the site diary.

## 7.0 INFORMATION MANAGEMENT

### Records

7.1 All records required by the Permit are held by the Operator. The operator keeps all records relating to the site at the main office.

7.2 The site diary/environmental log is maintained by the site management. Example template is shown in Appendix C. All records relating to the site are kept for a minimum of 2 years. The following significant events are recorded in the site diary:

- Maintenance of plant in accordance with manufacturer's recommendations;
- Breakdowns;
- Emergencies;
- Problems with material quality and action taken;
- Site inspections and consequent actions carried out by the operator. These include those undertaken by specialists;
- Technically competent management attendance at site;
- Any monitoring undertaken;
- Importation volumes and Duty of Care paperwork;
- Severe weather conditions which adversely affected site activities;
- Complaints (See complaints form and procedure in Appendix J); and
- Environmental problems and remedial actions (including spills and leaks).

### Inspection Regime

7.3 Site inspections are undertaken of the operations and associated boundary on operational days to check for unforeseen emissions and compliance with the Permit requirements. Inspections and corrective actions (including any required notifications to the EA) are recorded in the Site Diary. The main points for inspection include the following:

- Cleanliness;
- Site emissions;
- Leakages/spillages;
- Monitoring data;
- Plant condition; and
- Integrity of wider associated buildings, surfaces, drainage and security provisions (where applicable).

7.4 In the event that a problem is identified, the Manager organises immediate repair or other appropriate remedial action.

### Duty of Care

7.5 In accordance with Duty of Care requirements, the Operator maintains a schedule of all waste transfers from the site. The schedule and Duty of Care paperwork is made available for inspection, as required. Records are maintained at the Operator's main office.

### Availability of Permit and Management Plan

7.6 A copy of the Permit, all management plans and the supporting documents, is kept available on site. It must be available for reference when required by all site staff carrying out work under the requirements of the Permit.

### Review of Management Systems

7.7 The management systems is reviewed annually and updated following any of the following:

- If any changes to the site, operations or equipment which affect the activities covered by the permit;
- If the permit is varied;
- Following any accident, complaint or breach of permit;
- If a new environmental problem or issue is identified and new control measures are required.

7.8 All records of changes to the management system are recorded.

# DRAWINGS



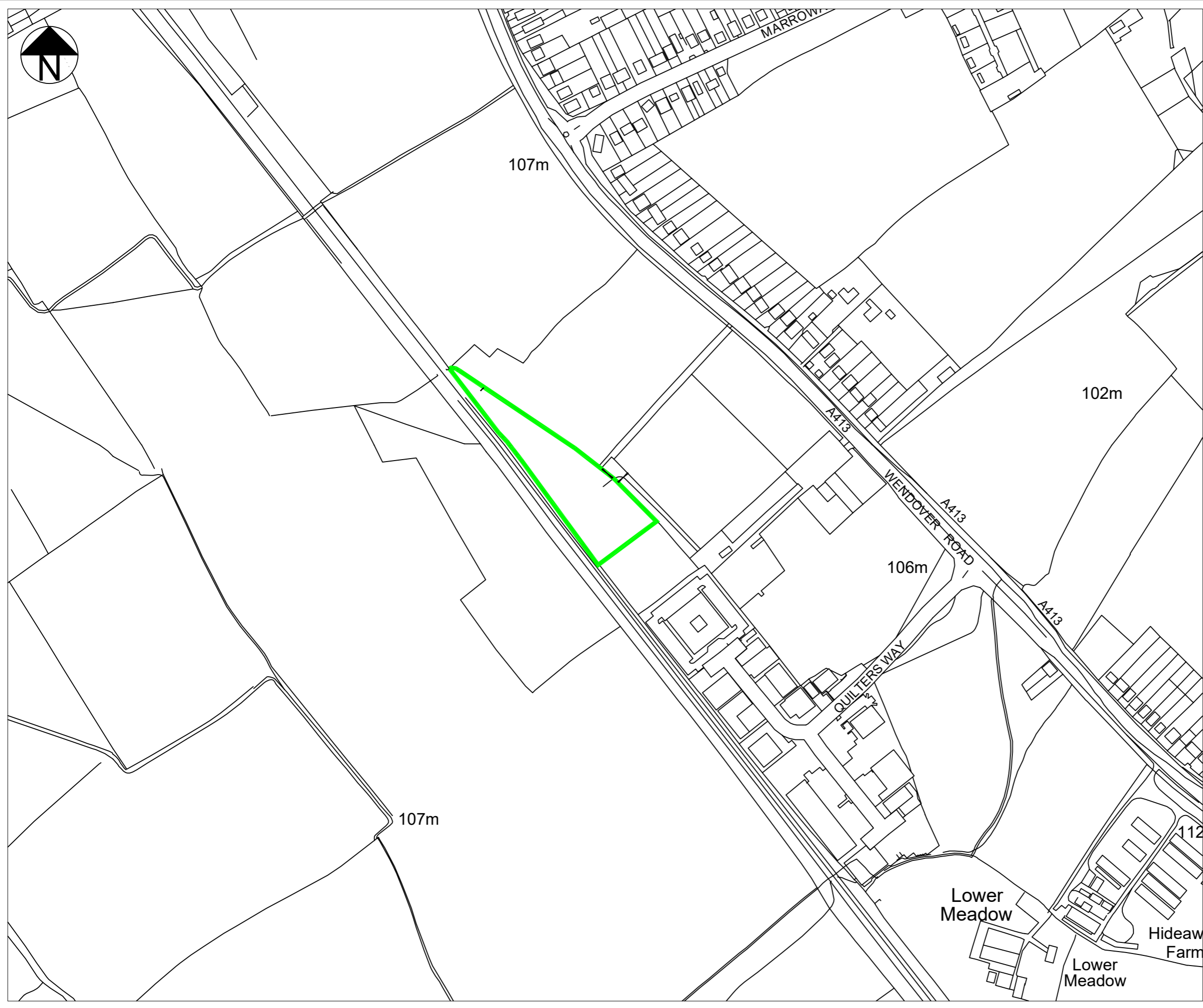
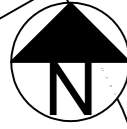

**KEY**

 Permit Boundary

The centre of the site is located at Site Grid reference SP8448309981

| Rev. | Details | Drawn Chkd. | Date |
|------|---------|-------------|------|
|------|---------|-------------|------|

Project  
 233036  
 Enterprise Skip Hire Limited  
 Stoke Mandeville

Title  
 Site Location Plan



**AA Environmental Ltd**  
 Units 4-8  
 Cholswell Court  
 Shippon Abingdon  
 Oxon OX13 6HX  
 T: (01235) 536042  
 F: (01235) 523849  
 info@aae-ltd.co.uk  
 www.aae-ltd.co.uk

|                    |                |            |             |                         |      |
|--------------------|----------------|------------|-------------|-------------------------|------|
| Scale<br>1:4000@A3 | Date<br>Jan'23 | Drwn<br>EF | Chkd.<br>EB | Drg. No.<br>233036D/001 | Rev. |
|--------------------|----------------|------------|-------------|-------------------------|------|

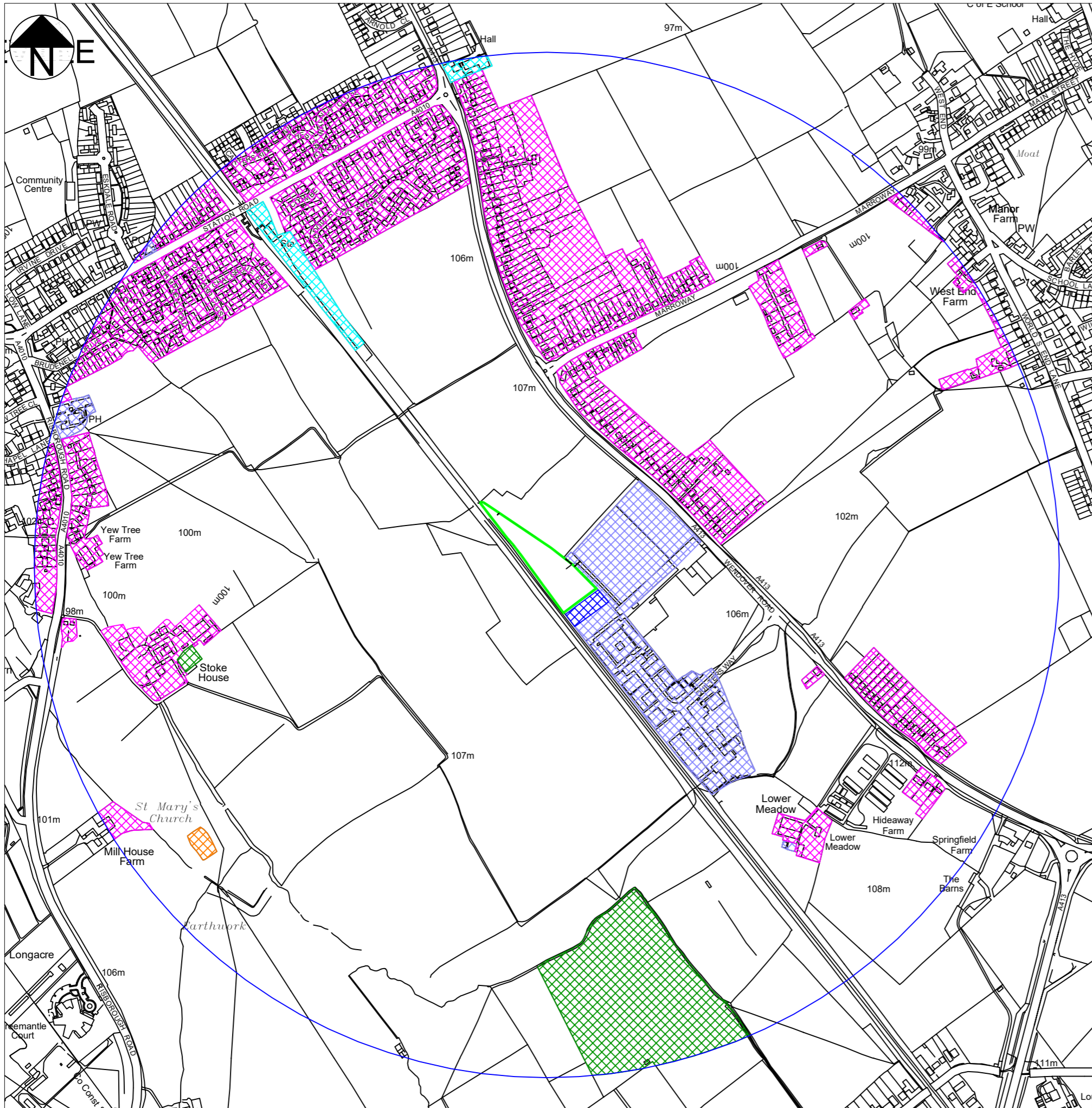

**KEY**

- Permit Boundary
- 1 km Radius
- ▨ Residential
- ▨ Commercial
- ▨ Industrial
- ▨ Archaeological
- ▨ Ecological
- ▨ Other

| Rev.        | Details   | Drawn        | Date |
|-------------|---|--------------|------|
|             | Project<br>233036<br>Enterprise Skip Hire Limited<br>Stoke Mandeville   | Chkd.        |      |
|             | Title<br>Sensitive Receptor Plan  |              |      |
|             |  <b>AAe</b><br>Environmental Consultants<br>AA Environmental Ltd<br>Units 4-8<br>Cholswell Court<br>Shippon Abingdon<br>Oxon OX13 6HX<br>T: (01235) 536042<br>F: (01235) 523849<br>info@aae-ltd.co.uk<br>www.aae-ltd.co.uk |              |      |
| Scale       | Date  | Drng. No.    | Rev. |
| 1:10,000@A3 | Feb'23  | 233036/D/002 |      |
|             | Drawn   | Chkd.        |      |
|             | EF  | EB           |      |



105m

Track

105m

Lined Lagoon

Hardcore / Inert Material

Plant Store

Hardcore / Inert Material

Workshop

Office

Entrance and Exit

Quarantine Area

Weighbridge

A26-29

Building 2

A23-25

Building B

A22

A21

A20

A18

A19

A16

Building A

A15

A10-14

Picking Station

A5

A7

A8

A9

Plant Store

Wind Netting  
(1 m on top of  
Concrete Wall)

- KEY**
- Permit Boundary
  - Operational Building
  - Quarantine Area
  - Impermeable Concrete Hardstanding

| Rev. | Details | Drawn<br>Chkd. | Date |
|------|---------|----------------|------|
|------|---------|----------------|------|

Project  
233036  
Enterprise Skip Hire Limited  
Stoke Mandeville

Title  
Site Layout Plan

**AA Environmental Ltd**  
Units 4-8  
Cholswell Court  
Shippon Abingdon  
Oxon OX13 6HX

T:(01235) 536042  
F:(01235) 523849  
info@aae-ltd.co.uk  
www.aae-ltd.co.uk

| Scale     | Date  | Apr '23 | Drg. No.     | Rev. |
|-----------|-------|---------|--------------|------|
| 1:1000@A3 | Drawn | EF      | Chkd.        | EB   |
|           |       |         | 233036/D/004 |      |

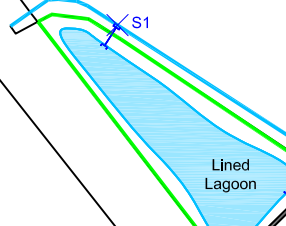

105m

Track

105m



**KEY**

- Permit Boundary
- Sub-Surface Drainage
- Land Drain Surface Water
- Rain Water Harvesting Tank
- Gully
- Building Cover
- Impermeable Concrete Hardstanding
- Surface Water Flow
- × Lined Lagoon Overflow Discharge Point

**Notes:**

1. Clean roof runoff goes straight to drainage ditch and/or soakaway.
2. S1 Easting = 484379.435, Northing = 210083.415

| Rev. | Details | Drawn | Date |
|------|---------|-------|------|
|      |         | Chkd. |      |

Project  
 233036  
 Enterprise Skip Hire Limited  
 Stoke Mandeville

Title  
 Drainage Plan

**AA Environmental Ltd**  
 Units 4-8  
 Cholswell Court  
 Shippon Abingdon  
 Oxon OX13 6HX

T: (01235) 536042  
 F: (01235) 523849  
 Info@aae-ltd.co.uk  
 www.aae-ltd.co.uk

| Scale     | Date  | Apr '23 | Drg. No.     | Rev. |
|-----------|-------|---------|--------------|------|
| 1:1000@A3 | Drawn | Chkd.   | 233036/D/005 |      |
|           | EF    | EB      |              |      |

# Schedules

## Schedule 1. Waste Management Operations

| Authorised Operations  | Limits of Operations   |
|--|--|
| <p><b>R13:</b> Storage of wastes pending any of the operations numbered R1 to R12 (excluding temporary storage, pending collection, on the site where it is produced).</p> <p><b>R3:</b> Recycling or reclamation of organic substances which are not used as solvents.</p> <p><b>R5:</b> Recycling or reclamation of other inorganic materials.</p> <p>R4: recycling of metals</p> <p>D9, D14 and D15 codes</p> | <ul style="list-style-type: none"> <li>Treatment consisting only of manual sorting, trommelling, shredding, separation, screening or crushing of waste into different components for recovery.</li> <li>Waste types listed in schedule 2 Table S2.1 and 2.2</li> </ul> |

## Schedule 2.1 Permitted Waste Types – storage and transfer

### Waste types and quantities

#### Maximum Quantities

The total quantity of waste accepted at the site shall be less than 125,000 tonnes a year

#### 02 WASTES FROM AGRICULTURE, HORTICULTURE, AQUACULTURE, FORESTRY, HUNTING AND FISHING, FOOD PREPARATION AND PROCESSING

02 01 Agriculture, forestry

02 01 10 Waste metal

#### 12 SHAPING/PHYSICAL TREATMENT OF METALS/PLASTICS

12 01 Wastes from shaping and physical and mechanical surface treatment of metals and plastics

12 01 01 Ferrous metal filings and turnings

12 01 03 Non-ferrous metal filings and turnings

12 01 05 Plastics shavings and turnings

12 01 13 Welding wastes

12 01 17 Waste blasting material other than those mentioned in 12 01 16

12 01 21 Spent grinding bodies and grinding materials other than those mentioned in 12 01 20

#### 15 WASTE PACKAGING; ABSORBENTS, WIPING CLOTHS, FILTER MATERIALS AND PROTECTIVE CLOTHING NOT OTHERWISE SPECIFIED

15 01 packaging (including separately collected municipal packaging waste)

15 01 01 paper and cardboard packaging

15 01 02 plastic packaging

15 01 03 wooden packaging

15 01 04 metallic packaging

15 01 05 composite packaging

15 01 07 glass packaging

15 01 09 textile packaging

15 02 Absorbents – filter materials – wiping cloths and protective clothing

15 02 03 Absorbents, filter materials, wiping cloths and protective clothing other than those mentioned in 15 02 02

#### 16 OTHER WASTES FROM INDUSTRIAL PROCESSES

16 01 end of life vehicles from different means of transport (including off-road machinery) and wastes from dismantling of end-of-life vehicles and vehicle maintenance (except 13 – 14 – 16 06 and 16 08)

16 01 03 end of life tyres

16 02 electrical and electronic equipment

16 02 14 discarded equipment other than those mentioned in 16 02 09 to 16 02 13

16 02 16 components removed from discarded equipment other than those mentioned in 16 02 15

16 06 batteries and accumulators

16 06 04 alkaline batteries (except 16 06 03)

|           |  |
|-----------|--|
| 16 06 05  | other batteries and accumulators   |
| <b>17</b> | <b>CONSTRUCTION AND DEMOLITION WASTES (INCLUDING EXCAVATED SOIL FROM CONTAMINATED SITES)</b>   |
| 17 02     | wood, glass and plastic  |
| 17 02 01  | Wood   |
| 17 02 02  | Glass  |
| 17 02 03  | Plastic  |
| 17 04     | metals (including their alloys)  |
| 17 04 01  | copper, bronze, brass  |
| 17 04 02  | aluminium  |
| 17 04 03  | lead   |
| 17 04 04  | zinc   |
| 17 04 05  | iron and steel   |
| 17 04 06  | tin  |
| 17 04 11  | cables other than those mentioned in 17 04 10  |
| 17 06     | Insulation materials and asbestos-containing construction materials  |
| 17 06 04  | Insulation materials other than those mentioned in 17 06 01 and 17 06 03   |
| 17 08     | gypsum-based construction material   |
| 17 08 02  | gypsum-based construction materials other than those mentioned in 17 08 01   |
| <b>19</b> | <b>WASTES FROM WASTE MANAGEMENT FACILITIES, OFF-SITE WASTE WATER TREATMENT PLANTS AND PREPARATION OF WATER INTENDED FOR HUMAN CONSUMPTION/INDUSTRIAL USE</b> |
| 19 12     | wastes from the mechanical treatment of waste (for example sorting, crushing, compacting, pelletising) not otherwise specified                               |
| 19 12 01  | Paper and cardboard  |
| 19 12 02  | Ferrous metal  |
| 19 12 03  | Non-ferrous metal  |
| 19 12 04  | Plastic and rubber   |
| 19 12 05  | Glass  |
| 19 12 07  | Wood   |
| 19 12 08  | Textiles   |
| 19 12 10  | Combustible waste (refuse derived fuel)  |
| <b>20</b> | <b>MUNICIPAL WASTES (HOUSEHOLD WASTE AND SIMILAR COMMERCIAL, INDUSTRIAL AND INSTITUTIONAL WASTES) INCLUDING SEPARATELY COLLECTED FRACTIONS</b>               |
| 20 01     | separately collected fractions (except 15 01)  |
| 20 01 01  | paper and cardboard  |
| 20 01 02  | glass  |
| 20 01 10  | clothes  |
| 20 01 11  | textiles   |
| 20 01 34  | batteries and accumulators   |
| 20 01 36  | discarded electrical and electronic equipment  |
| 20 01 38  | wood   |
| 20 01 39  | plastics   |
| 20 01 40  | metals   |

## Schedule 2.2 Permitted Waste Types – physical treatment

| Waste types and quantities  |   |
|---|---|
| Maximum Quantities  |   |
| The total quantity of waste accepted at the site shall be less than 125,000 tonnes a year |   |
| <b>01</b>   | <b>WASTES RESULTING FROM EXPLORATION, MINING, QUARRYING, AND PHYSICAL AND CHEMICAL TREATMENT OF MINERALS</b>              |
| 01 01   | wastes from mineral excavation  |
| 01 01 01  | wastes from mineral metalliferous excavation  |
| 01 01 02  | wastes from mineral non-metalliferous excavation  |
| 01 03   | Wastes from physical and chemical processing of metalliferous minerals  |
| 01 03 06  | Tailings other than those mentioned in 01 03 04 and 01 03 05  |
| 01 03 09  | Red mud from alumina production other than those mentioned in 01 03 07  |
| 01 04   | wastes from physical and chemical processing of non-metalliferous minerals  |
| 01 04 08  | waste gravel and crushed rocks other than those mentioned in 01 04 07   |
| 01 04 09  | waste sand and clays  |
| 01 04 11  | Wastes from potash and rock salt processing other than those mentioned in 01 04 07  |
| 01 04 12  | Tailings and other wastes from washing and cleaning of mineral other than those mentioned in 01 04 7 and 01 04 11         |
| 01 04 13  | wastes from stone cutting and sawing other than those mentioned in 01 04 07   |
| <b>02</b>   | <b>WASTES FROM AGRICULTURE, HORTICULTURE, AQUACULTURE, FORESTRY, HUNTING AND FISHING, FOOD PREPARATION AND PROCESSING</b> |
| 02 01   | Agriculture, forestry   |
| 02 01 03  | Plant tissue waste  |
| 02 01 07  | Wastes from forestry  |
| 02 04   | wastes from sugar processing  |
| 02 04 01  | soil from cleaning and washing beet   |
| <b>03</b>   | <b>WASTES FROM WOOD, PAPER, CARD PROCESSING</b>   |
| 03 01   | Wood processing and the production of panels and furniture  |
| 03 01 01  | Waste bark and cork   |
| 03 01 05  | Sawdust, shavings, cuttings, wood particle board and veneer other than those mentioned in 03 01 04                        |
| 03 03   | Pulp – paper and cardboard production and processing  |
| 03 03 01  | Waste bark and wood   |
| 03 03 07  | Mechanically separated rejects from pulping of waste paper and cardboard  |
| 03 03 08  | Wastes from sorting of paper and cardboard destined for recycling   |
| 03 03 10  | Fibre rejects, fibre- filler and coating sludges from mechanical separation   |
| <b>10</b>   | <b>WASTES FROM THERMAL PROCESSES</b>  |
| 10 11   | wastes from manufacture of glass and glass products   |
| 10 11 12  | waste glass other than those mentioned in 10 11 11  |
| 10 12   | wastes from manufacture of ceramic goods, bricks, tiles and construction products   |
| 10 12 08  | waste ceramics, bricks, tiles and construction products (after thermal processing)  |
| 10 13   | wastes from manufacture of cement, lime and plaster and articles and products made from them                              |
| 10 13 14  | waste concrete and concrete sludge  |
| <b>15</b>   | <b>WASTE PACKAGING; ABSORBENTS, WIPING CLOTHS, FILTER MATERIALS AND PROTECTIVE CLOTHING NOT OTHERWISE SPECIFIED</b>       |
| 15 01   | packaging (including separately collected municipal packaging waste)  |
| 15 01 06  | mixed packaging   |
| <b>16</b>   | <b>OTHER WASTES FROM INDUSTRIAL PROCESSES</b>   |
| 16 03   | Off-specification batches and unused products   |



|           |  |
|-----------|--|
| 16 03 04  | Inorganic wastes other than those mentioned in 16 03 03  |
| 16 03 06  | Organic wastes other than those mentioned in 16 03 05  |
| <b>17</b> | <b>CONSTRUCTION AND DEMOLITION WASTES (INCLUDING EXCAVATED SOIL FROM CONTAMINATED SITES)</b>   |
| 17 01     | concrete, bricks, tiles and ceramics   |
| 17 01 01  | Concrete   |
| 17 01 02  | Bricks   |
| 17 01 03  | tiles and ceramics   |
| 17 01 07  | mixtures of concrete, bricks, tiles and ceramics other than those mentioned in 17 01 06  |
| 17 04     | metals (including their alloys)  |
| 17 04 07  | mixed metals   |
| 17 05     | soil (including excavated soil from contaminated sites), stones and dredging spoil   |
| 17 05 04  | soil and stones other than those mentioned in 17 05 03   |
| 17 05 08  | track ballast other than those mentioned in 17 05 07   |
| 17 09     | other construction and demolition wastes   |
| 17 09 04  | mixed construction and demolition wastes other than those mentioned in 17 09 01, 17 09 02 and 17 09 03   |
| <b>19</b> | <b>WASTES FROM WASTE MANAGEMENT FACILITIES, OFF-SITE WASTE WATER TREATMENT PLANTS AND PREPARATION OF WATER INTENDED FOR HUMAN CONSUMPTION/INDUSTRIAL USE</b> |
| 19 12     | wastes from the mechanical treatment of waste (for example sorting, crushing, compacting, pelletising) not otherwise specified                               |
| 19 12 09  | minerals (for example sand, stones)  |
| 19 13     | Soil and groundwater remediation   |
| 19 13 02  | Solid wastes from soil remediation other than those mentioned in 19 13 01  |
| <b>20</b> | <b>MUNICIPAL WASTES (HOUSEHOLD WASTE AND SIMILAR COMMERCIAL, INDUSTRIAL AND INSTITUTIONAL WASTES) INCLUDING SEPARATELY COLLECTED FRACTIONS</b>               |
| 20 01     | separately collected fractions (except 15 01)  |
| 20 01 08  | Biodegradeable kitchen and canteen waste   |
| 20 01 41  | Waste from chimney sweeping  |
| 20 02     | garden and park wastes (including cemetery waste)  |
| 20 02 02  | soil and stones  |
| 20 03     | other municipal wastes   |
| 20 03 01  | mixed municipal waste  |
| 20 03 02  | Waste from markets   |
| 20 03 07  | bulky waste  |

## Appendix A

---

**001372**

**NSBP003 – NSBP006 Class 1 & 2 Bypass Separator  
Installation & Operation Guidelines**



---

Kingspan Environmental Service Contact Numbers:

GB: 0844 846 0500

NI: 028 3025 4077

IRL: 048 3025 4077

**Enclosed Documents**

|                  |  |
|------------------|--|
| <b>DS0993P</b>   | NSBP003 – NSBP006 Class 1 & 2 Bypass Separator |
| <b>DS1013P</b>   | NSBP003 - NSBP006 Installation Drawing         |
| <b>NSBEXT1zz</b> | NSBP Neck Extension Assembly                   |

| <b>Issue</b> | <b>Description</b> | <b>Date</b>    |
|--------------|--------------------|----------------|
| 04           | CC1091             | September 2012 |

---

## CONTENTS

|   | Page |
|---|------|
| CONTENTS.....   | 2    |
| 1 Introduction.....   | 3    |
| 1.2 Handling & Storage .....                                | 3    |
| 1.3 Site Planning.....                                      | 3    |
| 2 Installation .....  | 4    |
| 2.1 Installation - General .....                            | 4    |
| 2.2 Separator Installation.....                             | 5    |
| 2.3 Pipework Connections .....                              | 6    |
| 2.4 Oil Level Alarm Neck Fitting.....                       | 7    |
| 2.5 Alarm Installation.....                                 | 8    |
| 3 Operation.....  | 8    |
| 4 Maintenance.....  | 8    |
| 4.1 Waste Removal and Servicing.....                        | 8    |
| 4.2 Waste Removal Procedure – Oil & Silt.....               | 9    |
| 4.3 Checking the Coalescer Assembly.....                    | 9    |
| 4.4 Removing the coalescer assembly.....                    | 10   |
| 4.5 Cleaning the coalescer assembly/ Media Replacement..... | 10   |
| 4.6 Replacing the coalescer assembly.....                   | 10   |
| 5 Connection of Extension Neck .....                        | 10   |
| 6 Emergencies.....  | 11   |
| HEALTH & SAFETY .....                                       | 11   |
| <b>Appendices</b>   |      |
| Separator Maintenance Log                                   |      |

## 1 Introduction

- 1.1.1 These Guidelines represent Best Practice for the installation of the above Separator Units. Many years of specialist experience has led to the successful installation of thousands of separator units. It must be noted, however, that these Guidelines are necessarily of a general nature. It is the responsibility of others to verify that they are appropriate for the specific ground conditions and in-service loads of each installation. Similarly, any information or advice given by our employees or agents regarding the design of an installation must be verified by a qualified specialist (e.g. Civil engineering consultant).
- 1.1.2 For guidance of Separator selection and application, please refer to the most recent issue of Environment Agency Guidelines pollution prevention guidelines No. 3 (PPG3).and BS EN 858.

### 1.2 Handling & Storage

- 1.2.1 Care must be taken to ensure that units are not damaged during delivery and handling on site. Please take care and place unit so that it cannot fall and become damaged
- 1.2.2 The design requirements of these products will frequently mean that the centre of gravity of the unit is "offset". Care must therefore be taken to ensure that the unit is stable when lifting. Rainwater may also collect inside units, particularly if they have been stored on site prior to installation, adding weight and increasing instability. Check units before lifting and pump out any excess water.
- 1.2.3 When lifting units, use webbing slings of a suitable specification. Do not use chains.
- 1.2.4 A suitable spreader bar should be used to ensure that units are stable and that loads are evenly distributed during lifting. When lifting separators, a spreader bar should be used where the slings would otherwise be at an angle > 30 degrees to the vertical.
- 1.2.5 Lifting equipment should be selected by taking into account the unit weight, length and the distance of lift required on site.
- 1.2.6 We accept no responsibility for the selection of lifting equipment.
- 1.2.7 Whenever units are stored or moved on site, ensure that the storage location is free of rock, debris and any sharp objects, which may damage the unit. The units must be placed on ground, which is flat, and level and the unit orientated onto its side with even support. Do not roll separators.

### 1.3 Site Planning

The following points should be considered before installation of the equipment:

- 1.3.1 The discharge must have the consent of the relevant Environmental Regulator.
- 1.3.2 The installation should have Planning and Building Control approval.
- 1.3.3 Consider installing flow cut-off valves to isolate the separator in an emergency or during site cleaning operations. See Environment Agency Guidelines PPG3.
- 1.3.4 We will fit a tube to receive the alarm probe. This tube provides protection and ensures that the probe is positioned at the correct level to sense the oil build up. The tube design and probe level setting assumes the use of our standard oil alarm system and may not be suitable for other alarm supplier's equipment. The probe tube may be fitted either within the neck or within the body of the unit. It should be extended to ground level when fitted in the body of the tank and you should make provision to extend the tube to the required height before backfilling. Consult the alarm supplier's instructions for they're detailed fitting installation instructions.
- 1.3.5 Consider venting of the unit. Comply with local regulations. In the UK, comply with the following regulations. For Petrol Stations: Health and Safety Guidance Note 41 (HS(G)41). For other applications: BS8301: 1985 (obsolescent) BS EN 752 Building Drainage. Adequate ventilation should be provided to the separator. The ventilation pipe should be as short as is practicable and be terminated not less than 2.5m above paving nor less than 1m above the head of an openable window or other opening into a building within a horizontal distance of 3m. Each neck should be vented independently, we advise against joining these below ground prior to their rising as vent stacks.
- 1.3.6 Consider installation of a sampling point downstream of the separator. There is no suitable facility to effectively sample the wastewater from inside the unit.

- 1.3.7 Uncontaminated run off such as roof water should be excluded from separators. (EA Guidelines PPG3.)
- 1.3.8 Ground conditions and water table level should be assessed. If the water table will be above the base of the units at any time of the year, adequate concrete backfill must be provided to avoid flotation. In poorly draining ground, consideration should also be given to the likelihood of flotation due to surface water collecting in the backfill, and an appropriate installation method devised to avoid this.
- 1.3.9 If the discharge is to a soakaway, a porosity test should be carried out as part of the assessment of suitability for sub-soil drainage.
- 1.3.10 The separator must be installed at a level, which will allow connection to the incoming drain and a free discharge at the system outlet. The water table must be below the discharge outlet.
- 1.3.11 Do not install the unit deeper than necessary, ensure that you purchase extension shaft kits. The minimum invert depth of the unit is shown on the customer drawing.
- 1.3.12 Adequate access must be provided for routine maintenance. Vehicles should not be permitted within a distance equal to the depth of the unit, unless suitable structural protection is provided to the installation.
- 1.3.13 There must be at least 1 metre of clear, level ground all around the access covers to allow for routine maintenance.
- 1.3.14 It is essential that a mains water supply is accessible for routine cleansing and refilling after removal of waste material and liquid.
- 1.3.15 Provide electrical supply for alarm system.
- 1.3.16 Installation should only be carried out by suitably qualified and experienced contractors in accordance with current Health and Safety Regulations. Electrical work should be carried out by a qualified electrician, working to the latest edition of IEE wiring regulations.
- 1.3.17 This unit is designed to operate with gravity in and out flows. The unit is not designed to operate with a pumped influent.

## 2 Installation

### 2.1 Installation - General

- 2.1.1 When units are installed in unstable ground conditions where movement of the surrounding material and/or unit may occur, the connecting pipework should be designed to minimise the risk of damage from differential movement of the unit(s) and/or surrounding material.
- 2.1.2 For separators with burial depths greater than 1000mm from cover level to the top of the unit, specific site conditions should be taken into consideration and the backfill designed to bear any loads which may be applied during and after installation to prevent the tank being subjected to these loads.
- 2.1.3 The excavation must be deep enough to provide bedding and cover depth as determined by the type of surface pavement and loading. Asphalt and concrete pads should extend a minimum of 300mm horizontally beyond the unit in all directions.
- 2.1.4 In situations where the excavation will not maintain a vertical wall, it will be necessary to shore up the sidewalls of the excavation with suitable trench sheets and bracing systems to maintain a vertical wall from the bottom to the top of the excavation. DO NOT completely remove the shoring system until the backfilling is complete, but before the concrete fully hardens.
- 2.1.5 In areas where the water table is above the bottom of the excavation and/or the excavation is liable to flood, the excavation should be dewatered using suitable pumping equipment and this should continue until the installation is complete.
- 2.1.6 During installation care must be taken to ensure that the body of the unit is uniformly supported so that point loads through the unit are avoided.
- 2.1.7 The concrete Specification is not a site specific installation design.

| <b>GENERAL CONCRETE SPECIFICATION<br/>IN ACCORDANCE WITH BS EN 206-1 ( BS 8500-1)</b>                          |   |
|--|---|
| TYPE OF MIX  | (DC) DESIGN   |
| PERMITTED TYPE OF CEMENT   | BS 12 (OPC); BS 12 (RHPC); BS 4027 (SRPC)   |
| PERMITTED TYPE OF AGGREGATE<br>(coarse & fine)   | BS 882  |
| NOMINAL MAXIMUM SIZE OF AGGREGATE  | 20 mm   |
| GRADES:<br>C25 /30<br>C25 /30<br>C16 /20   | REINFORCED & ABOVE GROUND WITH HOLDING<br>DOWN BOLTS<br>REINFORCED (EG. FOR HIGH WATER TABLE)<br>UNREINFORCED (NORMAL CONDITIONS) |
| MINIMUM CEMENT<br>CONTENT  | C30<br>C20  |
|  | 270 - 280 Kg/M <sup>3</sup><br>220 - 230 Kg/M <sup>3</sup>  |
| SLUMP CLASS  | S1 (25mm)   |
| RATE OF SAMPLING   | READY MIX CONCRETE SHOULD BE SUPPLIED<br>COMPLETE WITH APPROPRIATE DELIVERY TICKET IN<br>ACCORDANCE WITH BS EN 12350-1            |
| NOTE: STANDARD MIXES SHOULD NOT BE USED WHERE SULPHATES OR OTHER AGGRESSIVE CHEMICALS<br>EXIST IN GROUND WATER |   |

- 2.1.8 Pea Shingle - 6 mm to 10 mm rounded pea shingle, offering low point loading characteristics is considered to be the most suitable material for back filling in dry ground installation. (PEASHINGLE ONLY TO BE USED IN DRY SITE CONDITIONS).

## 2.2 Separator Installation

### 2.2.1 DRY GROUND CONDITIONS

- 2.2.2 Excavate the site, allowing for a minimum clearance on all sides and base of the unit of 200mm and level the base.
- 2.2.3 Ensure that the hole is kept dry. Should any rain or surface water collect in the hole, this should be pumped out.
- 2.2.4 A base of at least 200mm of lean mix concrete should be provided.
- 2.2.5 Lower the tank in the hole using a rope sling through the lifting points provided on the tank. Under no circumstances should the sling be attached to the inlet pipe or the outlet pipe.
- 2.2.6 Position the inlet pipe in line with the incoming drain. Note that the inlet and the outlet pipes are clearly embossed on the tank. The unique profile of the base will help to level the tank, but make sure the tank is in the truly upright position in order to maintain the 25mm head difference between the inlet and outlet pipes.
- 2.2.7 After any concrete in the base has taken up its initial set (usually after one day), ballast the tank by putting approximately 0.5m depth of water into it.
- 2.2.8 Backfill the space around the tank with pea gravel or similar material (PEASHINGLE ONLY TO BE USED IN DRY SITE CONDITIONS). The backfill should be free from organic material, large stones, brick or sharp objects. Backfilling should be carried out in layers, making sure that voids are not left under and around the sides of the tank and that there are no localized stress concentrations. It is most important that the installer progressively fills the tank with water to the level above the backfill in order to stabilize pressures on the tank.
- 2.2.9 Remove any temporary covers and connect up the tank inlet and outlet pipe to your own pipework. Do not use reducers.
- 2.2.10 Backfilling can now proceed up to ground level in 300mm stages ensuring tank is ballasted in all chambers as you go.
- 2.2.11 A galvanized lockable manhole cover (600x600mm) and frame is to be fitted to suit specific site loadings, THE TANK MUST NOT BE LOAD BEARING. The top of the manhole should not be sat

below the local ground level. If necessary a further neck extension should be added to the tank to bring the cover up to ground level (see section 6).

2.2.12 Venting can be provided through the cover or a Tee piece arrangement on the outlet/inlet.

### 2.2.13 WET GROUND CONDITIONS

2.2.14 Excavate a hole to appropriate depth allowing at least 300mm for lean mix concrete and hard-core base. Allow for tank width plus at least 400mm with additional allowance for any necessary shuttering.

2.2.15 De-water the excavation using suitable pumping equipment. Ensure that the pump discharge does not saturate the ground in the immediate vicinity. In wet ground conditions the installer should ensure that the base is adequate to support the weight of the tank and its contents. If the base of the excavation is unstable, i.e. running sand or similar, excavate an additional 250-300mm below concrete levels and fill up with compacted hard-core. Place a sheet of polythene over the hard-core and up the sides of the excavation before putting in the concrete cradle.

2.2.16 Lay a bed of concrete (minimum 150mm thick) on top of the polythene at the base of the excavation. De-watering is to continue until you are satisfied that the concrete has cured.

2.2.17 Lower the tank onto the concrete bed, ensuring that the inlet and outlet are in the correct position. Ensure the tank is upright and then ballast it with water to a maximum of 500mm deep.

2.2.18 Haunch up the concrete bed at least 450mm all round the base, ensuring that all voids in the concrete are eliminated and at least 150mm of concrete is left below the tank base.

2.2.19 Backfill to the invert depth with concrete. Ensure that the water level inside the tank is maintained no more than 250-300mm above concrete backfill level. It is most important that the installer progressively fills the tank with water to a level above the backfill in order to stabilise pressure on the tank.

2.2.20 Backfill evenly all round the tank, consolidating in layers. The backfilling should start before the base has hardened and be a single continuous operation so that the tank has a full concrete jacket without joins.

2.2.21 DO NOT use vibrating rammers to consolidate concrete. DO NOT discharge concrete directly on to the tank. Ensure that the concrete is not too wet and that is tamped in around the tank.

2.2.22 Align and connect pipework.

2.2.23 Build up a shell of concrete around the neck of the tank to 150-200mm thickness before completing the backfill with a suitable material. Care must be taken to avoid distortion of the neck whilst concreting this area.

2.2.24 Fit cover and frame. Apply surface finish e.g. turf

2.2.25 Do not empty tank until the concrete backfill has cured. Tanks may be left filled with water.

## 2.3 Pipework Connections

2.3.1 In all cases, ensure that the outlet pipework level is maintained for correct operation. (Unless specified on the order, the fall across the unit will be as per the customer drawings).

2.3.2 Small units are generally fitted with **PVCu spigots** to both the outlet and the inlet.

2.3.3 Connect using the same size PVCu socket or a suitable reducer.

2.3.4 Larger units are generally fitted with **Our GRP** manufactured sockets.

2.3.5 The connecting pipework should be pushed into the socket. Ensure that the seal is secure and watertight before backfilling the pipe.

2.3.6 Alternatively, proprietary **flex seal couplings** can be obtained to fit over the outside of the site pipework and the outside of the GRP socket. When using this connection method, please be aware that the outside GRP laminate is not perfectly regular and that you may need to use a sealant on the outside diameter of the GRP. Take care not to over tighten the coupling when connecting to the GRP and ensure that the seal is secure before backfilling the pipe. Drawing DS0185 provides the



ID of our GRP sockets. The OD is variable, as the wall thickness can be up to 15-20 mm. If purchasing a flexseal coupling for use with clay /concrete, we suggest that a size 110 mm larger than the ID is selected.

#### **2.4 Oil Level Alarm Neck Fitting**

- 2.4.1 We will fit a tube to receive the oil alarm probe. This provides protection and ensures that the probe is positioned at the correct level to sense oil build up.
- 2.4.2 See alarm supplier information and ensure that the probe is placed within the tube and can be accessed from ground level.
- 2.4.3 Continue backfilling with concrete over the tank body to the required level. Build up a shell of concrete, minimum 225mm thick, around the access shaft(s). When using pea shingle continue to back fill up to required level. Temporarily strut the access shaft to avoid distortion. Temporarily strut the access shaft to avoid distortion.
- 2.4.4 Where we supply an extension shaft to meet a deeper invert requirement, a coalescer extension tube will be required. When fitting, ensure that the tube is extended to just below the surface so that the coalescer can easily be removed. Remove the coalescer from the unit before adding the extension tube. When refitting, ensure that the coalescer is correctly inserted and fully pushed into the base fitting. This is important and you must ensure that the coalescer is correctly located before putting the unit in to operation. Reattach the bracket to the extended neck so it lines up with the hole in the coalescer. Class 2 units NSBP do not require a coalescer extension.
- 2.4.5 It is advisable to seal the joints on the extension shafts (particularly on sites with high ground water) with proprietary sealant or by GRP lamination. Temporarily strut the extension neck(s) to avoid distortion during back filling. Where more than one neck section is required to suit a deep invert, consider back-filling section by section. If the extension neck is too long, it can be trimmed using a fine-toothed saw. The original fixing hole bolting the coalescer to the neck should be sealed.
- 2.4.6 Ensure that the vent socket if cut out, is replaced elsewhere. The maximum recommended inlet invert is 2000mm (using 500mm long extension sections). If you are installing a unit deeper than this then you must make your own arrangements for removing and replacing the coalescer. Consideration must be given to the depth of lift involved.
- 2.4.7 Continue back-filling, ensuring minimum 225mm concrete thickness around the access shaft/ extension neck and alarm access tube (as applicable). When using pea shingle back fill as required.
- 2.4.8 Mains powered Alarm Systems. See alarm suppliers installation instructions. Lay 82mm diameter PVCu underground ducting between the alarm panel location and the alarm probe position. The ducting should be 500mm below ground level and fitted with a drawstring for later cable insertion. Any changes of direction should be by long radius bend. If necessary, drill a suitable hole in the access shaft adjacent to the alarm probe terminal box, to accept the ducting and seal.
- 2.4.9 In traffic areas a suitable top slab must be constructed. The top slab should bear on a suitable foundation to prevent superimposed loads being transmitted to the unit and access shafts. Loads applied to covers and frames must bear on the top slab, not the access shaft.
- 2.4.10 The unit should be filled with clean water up to the invert level of the outlet pipe. Ensure the unit identification is placed/ marked inside the neck for future information. The unit is now ready for use.

## 2.5 Alarm Installation

- 2.5.1 Install the alarm probe and control panel, as per the Suppliers Alarm Installation Guidelines. Ensure that the probe is positioned correctly for the required storage of oil. The table below indicates the maximum volume of oil to be stored and the depth of floating oil expected in the separation chamber.

| Unit    | Recommended Minimum Oil Storage volumes in litres | Actual Oil Storage volume in litres | Max. (100%)Depth of floating oil (Static) |
|---------|---|-------------------------------------|---|
| NSBP003 | 45 litres   | 107                                 | 210mm                                     |
| NSBP004 | 60 litres   | 107                                 | 210mm                                     |
| NSBP006 | 90 litres   | 107                                 | 210mm                                     |

## 3 Operation

- 3.1.1 The unit is sized on treating a defined area and rainfall (5 mm/hour) EN.858 Part 1 and using the factor provided in the Environment agency guidelines PPG3. (0.0018 = 6.5mm/hr) The unit will treat the entire flow i.e. NSBP003 will treat a flow of 3 litres per second. If the flow is greater than this then the excess flow will bypass the main treatment chamber. A NSBP003 unit will work in bypass mode over 3 and up to 30 litres per second. Flows in excess of this will back up on to the site. During a storm, the rain falls and flushes any surface debris, silt or oil into the tank. This first flush, up to the maximum rated flow is fully treated. As the severity of the storm increases, so does the rate of flow increase. The liquid entering the separator after the first flush tends to be cleaner and so, in lower risk applications, is allowed to bypass the oil separation chamber for directly discharge.
- 3.1.2 The bypass unit has three chambers. The entire flow up to the units listed flow rating is fully treated and passes through all chambers. (E.g. NSBP003 treats 3 litres per second.)
- 3.1.3 Flows in excess of this rating will bypass the separation chamber and the liquid passes untreated to the outlet chamber.
- 3.1.4 The first chamber will accumulate silt and grit. The maximum volume that can be retained is the rating x 100 e.g. a NSBP003 is capable of holding 300 litres of silt.
- 3.1.5 The second / separating chamber is sized to separate oil at the rated flow rate and to accumulate the required oil storage volume. A NSBP003 maximum oil storage volume is 45 litres. An oil probe should be positioned to detect the accumulation of oil when there is no or low flow conditions. The probe should be positioned so that the alarm operates at 90% of the rated oil storage volume.
- 3.1.6 In bypass flow conditions, the flow moves directly from the inlet to the outlet chamber avoiding the separating chamber.
- 3.1.7 Separators can be purchased either as Class 2, or as Class 1. Class 1 Bypass Separators are fitted with a removable coalescer which also includes media to further improve the discharge quality. The coalescer media requires maintenance.
- 3.1.8 Bypass Class 1 & Class 2 Separators are not effective for the removal of soluble or emulsified pollutants such as oil/detergent mixes found in vehicle wash effluents. With permission such discharges should be drained to the foul sewer. Consult our technical department for Separation equipment to meet these applications.

## 4 Maintenance

### 4.1 Waste Removal and Servicing

- 4.1.1 Separated light liquid **must** be removed from separator when the oil capacity has been reached.
- 4.1.2 An oil level alarm system is available for purchase which gives warning when the separated light liquid/water interface level reaches 90% of the maximum recommended oil storage volume.

- 4.1.3 Separators should be inspected at least every six months or more frequently if experience dictates. A log should be maintained detailing the depth of oil found, any oil volume removed and any silt removal or cleaning carried out. A specimen maintenance log is included in the appendices.
- 4.1.4 Every site is different, in respect to the amount and type of silt generated by the drain design and installation. Frequently, the construction programme itself generates large and perhaps unusual quantities of silt and grit. We do recommend that following the initial installation, an inspection of the separator contents be made to check that building rubble has not entered the unit. Further inspections at 3 and 6 months should be made so as to be able to assess the volumes of silt and oil accumulated. The inspection and emptying programme can then be defined following the first 6 months site experience. We recommend leaving a maximum interval between inspections of 6 months.
- 4.1.5 Alarm probes should be removed and cleaned with water whenever waste material is removed from the separator. Please note the alarm may alert until the liquid level is replaced.
- 4.1.6 **Separator waste is a “special waste” under the terms of The Waste Management Code of Practice. The Code imposes a duty of care on the waste producer to ensure that the Cleansing contractor is registered with the Environment Agency and that the final disposal of the waste is to a licensed facility.**
- 4.1.7 You should consider the purchase of a maintenance service, which includes bi-annual inspections, removal of oil and silt, cleaning of the alarm probe and cleaning or replacement of the coalescer (where appropriate).
- 4.2 Waste Removal Procedure – Oil & Silt**
- 4.2.1 **Oil can only be effectively removed when there is no flow entering the unit. Isolate the unit and prevent flow from entering. Always remove the oil before attempting to remove the coalescer. If this is not done, when the coalescer is withdrawn the oil can coat the media surface and when replaced the oil may be forced through the media, contaminating the effluent.**
- 4.2.2 Remove the access cover and lower the desludging hose in to the separation chamber. Draw off the surface oil.
- 4.2.3 If removing the silt, lower the desludge hose to the base of the tank and empty the contents of the chamber. Ensure that you access and clean both compartments.
- 4.2.4 Remove the alarm probe, if fitted, clean with water and replace.
- 4.2.5 Consider the period of time that the coalescer has been installed and consider removing and inspecting (cleaning or replacing) the coalescer media. If removed, ensure that it is correctly replaced and secured into position. Replace the access covers. It is best to lower the water level to aid re-fitting.
- 4.2.6 Re-fill the separator with clean water up to the outlet level.
- 4.2.7 If an alarm is fitted, it will display an alarm condition until the separator is re-filled. Check alarm operation when unit full.
- 4.3 Checking the Coalescer Assembly**
- 4.3.1 Coalescers, where fitted, may be cleaned periodically to maintain efficiency. Coalescers should be checked following a major incident and replaced if necessary. Please contact us if you wish to purchase the coalescer media.
- 4.3.2 Identify the type and size of separator (shown on labels inside the access neck).
- 4.3.3 Assemblies weighing less than 25 Kg may be removed by hand. Heavier assemblies should be lifted by mechanical means. Any lifting device employed must be capable of lifting:
- 4.3.3.a In excess of the maximum assembly weight.
- 4.3.3.b The assembly completely out of the access shaft.
- 4.3.3.c Giving a smooth and controlled lift.
- 4.3.3.d Swinging the assembly to one side clear of the access shaft.

| Unit    | Dry Weight (Kg) | Wet Weight (Kg) | Silted Weight (Kg) | Replacement Media Part No. |
|---------|-----------------|-----------------|--------------------|----------------------------|
| NSBP003 | 5.7 kg          | ≈50 kg          | ≈60 kg             | 402715                     |
| NSBP004 | 5.7 kg          | ≈50 kg          | ≈60 kg             | 402715                     |
| NSBP006 | 5.7 kg          | ≈50 kg          | ≈60 kg             | 402715                     |

4.3.4 Ensure that the area around the access shaft is clear and that there is space to place the assembly once removed. If space is not available it will be necessary to support the assembly over the access shaft. e.g. by scaffold poles and platform.

4.3.5 Only remove the access cover when necessary to remove the assembly. Do not leave the access shaft uncovered and unattended.

**4.4 Removing the coalescer assembly.**

4.4.1 Undo and remove the bracket which secures the coalescer to the access shaft.

4.4.2 Lift the assembly with a smooth and steady motion. Coalescers will become lighter as water drains from the exposed media. Allow the water to drain completely. Assemblies blocked with fine silt may be very heavy.

4.4.3 Fully extract the assembly and set it down adjacent to the access shaft.

**4.5 Cleaning the coalescer assembly/ Media Replacement.**

4.5.1 Hose down the assembly using clean water at normal pressure. If the media is heavily contaminated with oil and silt, it may not be possible to clean it effectively by hosing. Do not allow untreated cleaning water to pass out of the unit. Continue hosing until the water runs clear.

4.5.2 To replace the media, undo the banding. Slide media off the core tube and slide new media on. Ensure all the apertures on the core tube are covered by the media. Re-secure or replace banding. Consider replacing media and banding every two years.

**4.6 Replacing the coalescer assembly.**

4.6.1 Position it over the access shaft.

4.6.2 Lower the assembly steadily into the access shaft ensuring that the end locates within the sump at the bottom of the tank. Re-secure the bracket.

4.6.3 Replace the access cover.

**5 Connection of Extension Neck**

(Option in 1800L Tanks only)

5.1.1 See the accompanying illustration.

5.1.2 Remove existing lid by unscrewing 8 screws and lifting off lid.

5.1.3 Apply mastic around flange of tank that joins to extension neck.

5.1.4 Place extension neck onto flange of the tank and screw down using 8 fixings.

5.1.5 Please refer to drawing NSBEXT1zz

5.1.6 Apply mastic to top face of extension piece that is joining to cover.

5.1.7 Place lid on top of extension neck and screw down using 8 fixings.

5.1.8 Backfill in 200mm stages with concrete (wet site) or peashingle (dry site), bracing neck during each stage until you reach the cover level.

5.1.9 For traffic area loading ensures you refer to tank installation section.

## 6 Emergencies

- 6.1.1 At sites where there is a high risk of spillage, spill kits containing drain seals, absorbent materials, disposal containers and other appropriate equipment should be held. In the event of a spillage on site, the material should be contained, (if a spill kit is not available, sand or soil may be used) and the Environment Agency notified immediately using the appropriate emergency hotline number listed in the Agency Guideline PPG3. Year 2012 - **0800 80 70 60**

## HEALTH & SAFETY

**These warnings are provided in the interest of safety. You must read them carefully before installing or using the equipment.**

It is important that this document is retained with the equipment for future reference. Should the equipment be transferred to a new owner, always ensure that all relevant documents are supplied in order that the new owner can be acquainted with the functioning of the equipment and the relevant warnings.

Installation should only be carried out by a suitably experienced contractor, following these guidelines.

We recommend the use of a dust mask and gloves when cutting GRP components.

Electrical work should be carried out by a qualified electrician.

Contaminated surface water can contain substances harmful to human health. Any person carrying out maintenance on the equipment should wear suitable protective clothing, including gloves. Good hygiene practice should also be observed.

Access covers should be selected with reference to the location of the unit and traffic loads to be accommodated. These are not (normally) part of the Separator supply.

When covers are removed precautions must be taken against personnel falling into the unit.

Should you wish to inspect the operation of the equipment, please observe all necessary precautions, including those listed below, which apply to maintenance procedures.

Ensure that you are familiar with the safe working areas and accesses. Ensure that the working area is adequately lit.

Take care to maintain correct posture, particularly when lifting. Use appropriate lifting equipment when necessary. Keep proper footing and balance at all times. Avoid any sharp edges.

### OIL ALARM SYSTEMS

PPG3 requires that the oil level alarm be fitted, tested and commissioned by a competent Installer. This is to ensure that the excessive oil probe is calibrated correctly, raising an alarm when 90% of the recommended maximum oil storage volume is reached. Should the oil level alarm fail to provide an early warning, excessive oil could pass through the separator, thus polluting the environment. This could result in substantial cleanup costs and legal action being taken under the water resources act 1991.

### MAINTENANCE

The correct ongoing maintenance is essential for the proper operation of the equipment. Operators who rely on oil level alarms to prompt them to service separators between maintenance intervals run the risk of polluting should the alarms not work, hence the ongoing functional assessment of the oil alarm systems is fundamental if pollution incidents are to be avoided.

The removal of sediment and retained oil/grease should be carried out by a contractor holding the relevant permits to transport and dispose of such waste. The contractor must refer to the guidelines in this document.



## Appendix B

# CERTIFICATE OF CONFORMITY



This is to certify that Alpine Security (UK) Ltd are registered with the Security Systems and Alarms Inspection Board (SSAIB) and that the system below conforms to the relevant British, European or other Standard or Codes of Practice as detailed below.

**Certificate Number**  
1549301

**System Type**  
CCTV Systems

## Customer Details

## System Details

|  |  |
|--|--|
| Customer's Name<br>Enterprise Skiphire Ltd   | Applicable Standards<br>SSAIB CoP SS2003 CCTV Code of Practice |
| Address<br>Wendover Road<br>Stoke Mandeville<br>Aylesbury<br>Buckinghamshire<br>HP22 5GX |  |
| Installation Ref. No.<br>AS010422-CCTV   |  |
| Date Commissioned<br>01/04/2022  |  |

## REGISTERED FIRM

Alpine Security (UK) Ltd (SUFF011)  
13 Whitworth way  
Wilstead  
Bedford  
Bedfordshire  
MK45 3DX  
Tel: 08000 842 741

|            |  |
|------------|--|
| Signature: | Installer Name: Alpine Security (UK) Ltd |
|            | Date: 25/10/2022                         |

### Important Notes to Customer:

1. This certificate is only valid if the reference number is not defaced, modified or deleted.
2. The reference number of this certificate must be quoted in any correspondence relating to this system.
3. In the event of a dispute relating to quality of work or compliance with standards which the customer has been unable to resolve directly with the installer, the SSAIB will investigate upon receipt of the customers written request.
4. This certificate does not express or imply that SSAIB gives any warranty or accepts any responsibility for any failure or defect that may occur, now or hereafter relating to the products or services supplied by the installer.

SSAIB, 7-9 Earsdon Road, West Monkseaton, Whitley Bay, NE25 9SX



# DH-IPC-HFW3549T1-AS-PV

5MP Full-color Active Deterrence Fixed-focal Bullet WizSense Network Camera



**Wiz Sense**

Launched by Dahua Technology, WizSense is a series of AI products and solutions that adopt independent AI chip and deep learning algorithm. It focuses on human and vehicle with high accuracy, enabling users to fast act on defined targets. Based on Dahua's advanced technologies, WizSense provides intelligent, simple and inclusive products and solutions.

## Series Overview

With advanced deep learning algorithm, Dahua WizSense 3 Series network camera supports intelligent functions, such as perimeter protection and smart motion detection. In addition, with full-color technology, it provides a better image effect in the condition of low illuminance.

## Functions

### SMD Plus

With intelligent algorithm, Dahua Smart Motion Detection technology can categorize the targets that trigger motion detection and filter the motion detection alarm triggered by non-concerned targets to realize effective and accurate alarm.

### Smart H.265+ & Smart H.264+

With advanced scene-adaptive rate control algorithm, Dahua smart encoding technology realizes the higher encoding efficiency than H.265 and H.264, provides high-quality video, and reduces the cost of storage and transmission.

### Full-color

With high-performance sensor and large aperture lens, Dahua Full-color technology can display clear colorful image in the environment of ultra-low illuminance. With this photosensitivity technology, the camera can capture more available light, and display more colorful image details.

### Siren and Light Active Deterrence

Dahua siren and light active deterrence network camera supports light alarm and voice alarm when perimeter event occurs, to realize the deterrence and effective intervention. The camera is built in multiple voices for selection, and supports customized voice importing.

- 5MP, 1/2.7" CMOS image sensor, low illuminance, high image definition
- Outputs max. 5MP (2592 × 1944) @20 fps, and supports 4MP (2688 × 1520) @25/30 fps
- H.265 codec, high compression rate, low bit rate
- Built-in warm illuminator, and the max. illumination distance: 40 m
- ROI, SMART H.264+/H.265+, flexible coding, applicable to various bandwidth and storage environments
- Rotation mode, WDR, 3D NR, HLC, BLC, digital watermarking, applicable to various monitoring scenes
- Intelligent detection: Intrusion, tripwire (support the classification and accurate detection of vehicle and human)
- Abnormality detection: Motion detection, video tampering, scene changing, audio detection, no SD card, SD card full, SD card error, network disconnection, IP conflict, illegal access, and voltage detection.
- Supports sound and light alarm linkage. When an alarm is triggered, the camera links sound alarm and light flashing.
- Supports one-tap disarming. You can disarm the events of alarm output, sending email, audio, and light in the configured period.
- Alarm: 1 in, 1 out; audio: 1 in, 1 out; supports max. 256 G Micro SD card, built-in Mic and speaker
- 12V DC/PoE power supply
- IP67 protection
- SMD Plus
- Red and blue flashlight alarm



## Cyber Security

Dahua network camera is equipped with a series of key security technologies, such as security authentication and authorization, access control, trusted protection, encrypted transmission, and encrypted storage, which improve its security defense and data protection, and prevent malicious programs from invading the device.

## Protection (IP67, wide voltage)

**IP67:** The camera passes a series of strict test on dust and soak. It has dust-proof function, and the enclosure can works normal after soaking in 1 m deep water for 30 minutes.

**Wide voltage:** The camera allows  $\pm 30\%$  input voltage tolerance (wide voltage range), and it is widely applied to outdoor environment with instable voltage.

**Technical Specification**

**Camera**

|                            |   |
|----------------------------|---|
| Image Sensor               | 1/2.7"5Megapixel progressive CMOS                 |
| Max. Resolution            | 2592 (H) × 1944 (V)                               |
| ROM                        | 128 MB  |
| RAM                        | 512 MB  |
| Scanning System            | Progressive                                       |
| Electronic Shutter Speed   | Auto/Manual 1/3 s–1/100,000 s                     |
| Min. Illumination          | 0.003 Lux @ F1.0                                  |
| S/N Ratio                  | > 56 dB   |
| Illumination Distance      | 40 m (131.2 ft)                                   |
| Illuminator On/Off Control | Auto/Manual                                       |
| Illuminator Number         | 2 (Warm light)                                    |
| Pan/Tilt/Rotation Range    | Pan: 0°–360°<br>Tilt: 0°–90°<br>Rotation: 0°–360° |

**Lens**

|                      |  |                    |                   |                  |                  |
|----------------------|--|--------------------|-------------------|------------------|------------------|
| Lens Type            | Fixed-focal  |                    |                   |                  |                  |
| Mount Type           | M12  |                    |                   |                  |                  |
| Focal Length         | 2.8 mm; 3.6 mm; 6 mm   |                    |                   |                  |                  |
| Max. Aperture        | F1.0   |                    |                   |                  |                  |
| Field of View        | 2.8 mm: Horizontal 98° × Vertical 71° × Diagonal 129°<br>3.6 mm: Horizontal 77° × Vertical 56° × Diagonal 101°<br>6 mm: Horizontal 53° × Vertical 40° × Diagonal 66° |                    |                   |                  |                  |
| Iris Type            | Fixed  |                    |                   |                  |                  |
| Close Focus Distance | 2.8 mm: 1.2 m (3.9 ft)<br>3.6 mm: 2.1 m (6.9 ft)<br>6 mm: 4.5 m (14.8 ft)  |                    |                   |                  |                  |
| DORI Distance        | Lens   | Detect             | Observe           | Recognize        | Identify         |
|                      | 2.8 mm   | 67.4 m (221.1 ft)  | 27 m (88.6 ft)    | 13.5 m (44.3 ft) | 6.7 m (22.0 ft)  |
|                      | 3.6 mm   | 80.0 m (262.5 ft)  | 32.0 m (105.0 ft) | 16.0 m (52.5 ft) | 8.0 m (26.2 ft)  |
|                      | 6 mm   | 120.0 m (393.7 ft) | 48.0 m (157.5 ft) | 24.0 m (78.7 ft) | 12.0 m (39.4 ft) |

**Professional, intelligent**

|                            |  |
|----------------------------|--|
| IVS (Perimeter Protection) | Tripwire; intrusion (support the classification and accurate detection of vehicle and human)                     |
| Intelligent Search         | Work together with Smart NVR to perform refine intelligent search, event extraction and merging to event videos. |

**Video**

|                   |  |
|-------------------|--|
| Video Compression | H.265; H.264; H.264H; H.264B; MJPEG (only supported by the sub stream)   |
| Smart Codec       | Smart H.265+/Smart H.264+  |
| Video Frame Rate  | Main stream: 2592 × 1944 @1-20 fps/<br>2688 × 1520 @1-25/30 fps<br>Sub stream: 704 × 576 @1-25 fps/704 × 480 @ 1-20fps<br>Third stream: 1920 × 1080 @1-25/30 fps |
| Stream Capability | 3 streams  |

|                             |   |
|-----------------------------|---|
| Resolution                  | 5M (2592 × 1944); 4M (2688 × 1520); 4M (2560 × 1440); 3M (2304 × 1296); 1080p (1920 × 1080); 1.3M (1280 × 960); 720p (1280 × 720); D1 (704 × 576/704 × 480); VGA (640 × 480); CIF (354 × 288/354 × 240) |
| Bit Rate Control            | CBR/VBR   |
| Video Bit Rate              | H.264: 32 kbps–8192 kbps<br>H.265: 12 kbps–8192 kbps  |
| Day/Night                   | Color/B/W   |
| BLC                         | Yes   |
| HLC                         | Yes   |
| WDR                         | 120 dB  |
| Scene Self-adaptation (SSA) | Yes   |
| White Balance               | Auto/natural/street lamp/outdoor/manual/regional custom   |
| Gain Control                | Auto/Manual   |
| Noise Reduction             | 3D NR   |
| Motion Detection            | OFF/ON (4 areas)  |
| Region of Interest (RoI)    | Yes (4 areas)   |
| Smart Illumination          | Yes   |
| Image Rotation              | 0°/90°/180°/270° (Support with 2592×1944 resolution and lower)  |
| Mirror                      | Yes   |
| Privacy Masking             | 4 areas   |

**Audio**

|                   |                                    |
|-------------------|------------------------------------|
| Built-in MIC      | Yes                                |
| Audio Compression | PCM; G.711a; G.711Mu; G.726; G.723 |

**Alarm**

|             |   |
|-------------|---|
| Alarm Event | No SD card; SD card full; SD card error; network disconnection; IP conflict; illegal access; motion detection; video tampering; tripwire; intrusion; scene changing; audio detection; voltage detection; external alarm; SMD; safety exception; light alarm; sound alarm (11 built-in sounds and custom voices importing) |
|-------------|---|

**Network**

|                  |   |
|------------------|---|
| Network          | RJ-45 (10/100 Base-T)   |
| SDK and API      | Yes   |
| Protocol         | IPv4; IPv6; HTTP; TCP; UDP; ARP; RTP; RTSP; RTCP; RTMP; SMTP; FTP; SFTP; DHCP; DNS; DDNS; QoS; UPnP; NTP; Multicast; ICMP; IGMP; NFS; SAMBA; PPPoE; SNMP  |
| Cyber Security   | Video encryption; firmware encryption; configuration encryption; Digest; WSSE; account lockout; security logs; IP/MAC filtering; generation and importing of X.509 certification; syslog; HTTPS; 802.1x; trusted boot; trusted execution; trusted upgrade |
| Interoperability | ONVIF( Profile S/Profile G/Profile T); CGI; Milestone; Genetec; P2P   |
| User/Host        | 20 (Total bandwidth: 80 M)  |
| Storage          | FTP; SFTP; Micro SD card (support max. 256 G); NAS  |
| Browser          | IE: IE8 and later<br>Chrome<br>Firefox<br>Safari: Safari 12 and later   |

|                     |                      |
|---------------------|----------------------|
| Management Software | Smart PSS; DSS; DMSS |
| Mobile Phone        | IOS; Android         |

## Certification

|               |   |
|---------------|---|
| Certification | CE-LVD: EN62368-1<br>CE-EMC: Electromagnetic Compatibility Directive 2014/30/EU<br>FCC: 47 CFR FCC Part 15, Subpart B |
|---------------|---|

## Port

|              |                             |
|--------------|-----------------------------|
| Audio Input  | 1 channel (RCA port)        |
| Audio Output | 1 channel (RCA port)        |
| Alarm Input  | 1 channel in: 5mA 3V–5V DC  |
| Alarm Output | 1 channel out: 300mA 12V DC |

## Power

|                   |  |
|-------------------|--|
| Power Supply      | 12V DC/PoE (802.3af)   |
| Power Consumption | Basic power consumption: 2W (12V DC); 2.6W (PoE)<br>Max. power consumption (H.265 + warm light + IVS + sound alarm + red and blue lights flash): 7.5W (12V DC); 8.8W (PoE) |

## Environment

|                      |   |
|----------------------|---|
| Operating Conditions | –40°C to +60°C (–40°F to +140°F)/Less than 95% RH |
| Storage Conditions   | –40°C to +60°C (–40°F to +140°F)                  |
| Protection Grade     | IP67  |

## Structure

|              |   |
|--------------|---|
| Casing       | Metal + plastic   |
| Dimensions   | 288.4 mm × 94.4 mm × 84.7 mm<br>(11.4" × 3.7" × 3.3") (L × W × H) |
| Net Weight   | 1.0 kg (2.2 lb)   |
| Gross Weight | 1.23 kg (2.7 lb)  |

## Ordering Information

| Type                   | Part Number             | Description   |
|------------------------|-------------------------|---|
| 5MP Camera             | DH-IPC-HFW3549T1P-AS-PV | 5MP Full-color Active Deterrence Fixed-focal Bullet WizSense Network Camera, PAL  |
|                        | DH-IPC-HFW3549T1N-AS-PV | 5MP Full-color Active Deterrence Fixed-focal Bullet WizSense Network Camera, NTSC |
|                        | IPC-HFW3549T1P-AS-PV    | 5MP Full-color Active Deterrence Fixed-focal Bullet WizSense Network Camera, PAL  |
|                        | IPC-HFW3549T1N-AS-PV    | 5MP Full-color Active Deterrence Fixed-focal Bullet WizSense Network Camera, NTSC |
| Accessories (optional) | PFA130-E                | Junction Box  |
|                        | PFA152-E                | Pole Mount  |
|                        | PFM321D                 | 12V DC 1A Power Adapter   |
|                        | LR1002-1ET/1EC          | Single-port Long Reach Ethernet over Coax Extender                                |

|  |          |                         |
|--|----------|-------------------------|
|  | PFM900-E | Integrated Mount Tester |
|  | PFM114   | TLC SD Card             |

## Accessories

### Optional:

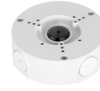

PFA130-E  
Junction Box



PFA152-E  
Pole Mount



PFM321D  
12V DC 1A Power Adapter



LR1002-1ET/1EC  
Single-port Long Reach Ethernet over Coax Extender



PFM900-E  
Integrated Mount Tester



PFM114  
TLC SD Card

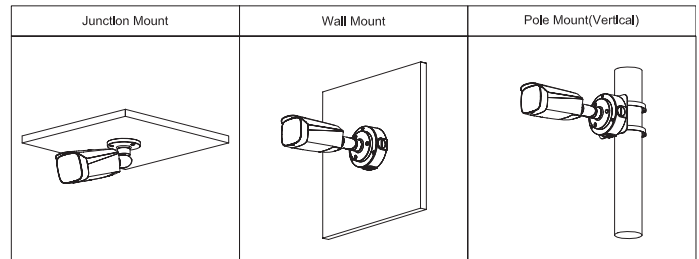

## Dimensions (mm/inch)

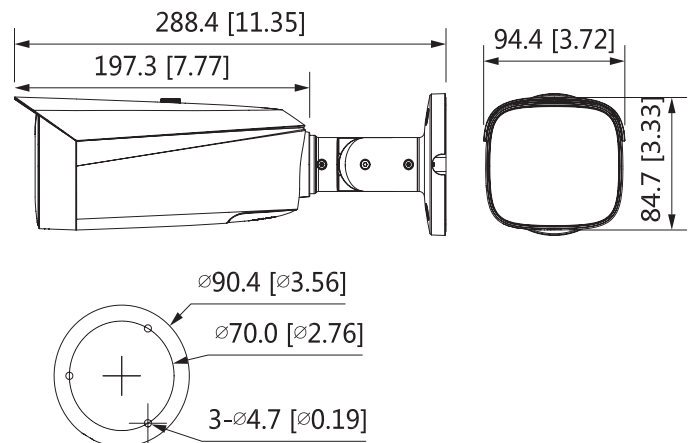

# System Design Proposal

**Surveyor:** Danny Bates

**Date** 01/04/2022

**Address:** Enterprise Waste Management, Wendover Rd, Stoke Mandeville, Aylesbury, HP22 5GX

## System Design Proposal for the Installation of a CCTV System

### Description of Premises; whatever the type of premises

This design is based on a survey of the premises and information available at the time, including any valuation(s) or other information provided by the customer or the customer's representatives.

You are advised to consult with your insurer in relation to this CCTV System Design Proposal

Every care has been taken during the preparation of the proposal to ensure it complies with the relevant standards and the SSAIB Codes of Practice for CCTV Version 6 June 2016.

**Reason for System -** Event Recording

**Type of Recording -** Continuous Recording

**Format of Recording –** IP

**Method of Recording** – is by a 16 channel 6 TB NVR with remote viewing & recording method of retrieving video images is via USB Stick or via a PC providing a minimum of 21 days recording, if type of recording is by event then this is recording time is dependent on the activity in the specific area

This design proposal conforms to: SSAIB CCTV Code of Practice.

**Objective:** - The objective of the proposed system is to give general detection of people in all areas along with recognition & identification of people in specified areas and heat detection specified areas as follows:

### DEVICES

**Camera No. 1**                      **General Detection**                      **5MP IP**                      **External**

One Day/Night bullet camera (model IHFW3549T1P-AS-PV28) to be sited on the front LHS of the furniture store unit directed towards the car park to cover the visitor car park at a height of approximately 4.5 meters.

**Camera No. 2**                      **General Detection**                      **5MP IP**                      **External**

One Day/Night bullet camera (model IHFW3549T1P-AS-PV28) to be sited on the front RHS of the furniture store unit directed towards the car park to cover the visitor car park and car park entrance at a height of approximately 4.5 meters.

**Camera No. 3**                      **General Detection**                      **5MP IP**                      **External**

One Day/Night bullet camera (model IHFW3549T1P-AS-PV28) to be sited on the right-side front of the furniture store unit directed towards the car park to cover the skip lorry car park at a height of approximately 4.5 meters.

**Camera No. 4**                      **General Detection**                      **5MP IP**                      **External**

One Day/Night bullet camera (model IHFW3549T1P-AS-PV28) to be sited on the right-side back of the furniture store unit directed towards the car park to cover the skip lorry car park at a height of approximately 4.5 meters.

**Camera No. 5**                      **General Detection**                      **5MP IP**                      **External**

One Day/Night bullet camera (model IHFW3549T1P-AS-PV28) to be sited on back RHS of the furniture store unit directed towards the car park to cover the staff car park at a height of approximately 4.5 meters.

**Camera No. 6**                      **General Detection**                      **5MP IP**                      **External**

One Day/Night bullet camera (model IHFW3549T1P-AS-PV28) to be sited on front of the skip yard office unit directed towards the front entry to cover the front vehicle entry at a height of approximately 4.5 meters.

**Camera No. 7**                      **General Detection**                      **5MP IP**                      **External**

One Day/Night bullet camera (model IHFW3549T1P-AS-PV28) to be sited on LHS of the skip yard office unit directed towards the side sorting area to cover the vehicles and skips at a height of approximately 4 meters.

**Camera No. 8**                      **General Detection**                      **5MP IP**                      **External**

One Day/Night bullet camera (model IHFW3549T1P-AS-PV28) to be sited on back LHS of the skip yard office unit directed towards the back area to cover the back area at a height of approximately 4 meters.

**Camera No. 9**                      **General Detection**                      **5MP IP**                      **External**

One Day/Night bullet camera (model IHFW3549T1P-AS-PV28) to be sited on back RHS of the skip yard office unit directed towards the outside of the workshop entrance to cover the outside of the workshop entrance at a height of approximately 4 meters.

**Camera No. 10**                      **General Detection**                      **5MP IP**                      **External**

One Day/Night bullet camera (model IHFW3549T1P-AS-PV28) to be sited on front of the picking belt unit directed towards the sorting area to cover the sorting area at a height of approximately 4 meters.

**Camera No. 11**                      **General Detection**                      **5MP IP**                      **External**

One Day/Night bullet camera (model IHFW3549T1P-AS-PV28) to be sited on back LHS of the picking belt unit directed towards the skip store entry to cover the vehicles and skips at a height of approximately 4 meters.

**Camera No. 12**                      **General Detection**                      **5MP IP**                      **External**

One Day/Night bullet camera (model IHFW3549T1P-AS-PV28) to be sited on back RHS of the picking belt unit directed towards the back of the skip store to cover the skips and back fence line at a height of approximately 4 meters.

**Camera No. 13**                      **Temperature Measurement**                      **Thermal**                      **External**

One Thermal Network Bullet Camera (7.5mm Lens, Temperature Measurement) camera (model TPC-BF5601P-TB7) to be sited on the front LHS of the picking belt unit directed towards the wood chip pile to cover the wood chip pile at a height of approximately 4 meters.

**Camera No. 14**                      **Temperature Measurement**                      **Thermal**                      **External**

One Thermal Network Bullet Camera (7.5mm Lens, Temperature Measurement) camera (model TPC-BF5601P-TB7) to be sited in the front RHS of the picking belt unit directed towards the waste sorting pile to cover the waste sorting pile at a height of approximately 4 meters.

**Camera No. 15      Temperature Measurement      Thermal      External**

One Thermal Network Bullet Camera (7.5mm Lens, Temperature Measurement) camera (model TPC-BF5601P-TB7) to be sited in the front LHS of the waste holding unit directed towards the new waste pile to cover the new waste pile at a height of approximately 4 meters.

**Camera No. 16      Temperature Measurement      Thermal      External**

One Thermal Network Bullet Camera (7.5mm Lens, Temperature Measurement) camera (model TPC-BF5601P-TB7) to be sited in the front middle of the picking belt unit directed towards the waste drop off area to cover the waste drop off area at a height of approximately 4 meters.

**CAMERA SPECIFICATION**

Model IHFW3549T1P-AS-PV28 (specification attached)

Model TPC-BF5601P-TB7 (specification attached)

**CONTROL EQUIPMENT**

**Recording Equipment: -**

One 16 channel Viper NVR with a 6TB hard drive will be fitted on to the office floor, the system is setup to record at 10 fps recording on event and 3 fps on schedule. Footage recovery is by USB memory stick or via a PC with the CMS software.

The unit will require a 230V supply socket fitted in close proximity of the control equipment.

**Monitors: -**

One 50" Monitor is to be sighted in the manager's office.

**Other Equipment: -**

There will be 2, 8 port POE switches located in an enclosure on the front of the picking belt unit to power and network cameras.

There will be 1, 8 port POE switch located in the furniture store unit to power and network cameras.

**NOTIFICATIONS**

The system will be programmed to send push notifications to designated phones upon an event activation. E.G. heat spike.

**DATA PROTECTION**

Your attention is drawn to compliance with the CCTV data protection legislation (Data protection Act 1998).

The Act applies to commercial and public CCTV systems only, and is enforceable where a CCTV system obtains, records, or stores personal data in the form of video images.

Your CCTV system may need to be registered by notifying the Information Commissioner at [www.informationcommissioner.gov.uk](http://www.informationcommissioner.gov.uk) or telephone 01625 545740. The notification period is one year and the fee is £35. **Warning signs must be displayed to show that CCTV cameras are recording, stating the purpose of the system and including details of who manages the system and contact details.**

For more information, contact the information commissioner at [www.informationcommissioner.gov.uk](http://www.informationcommissioner.gov.uk) or telephone 01625 545740.

**MANAGEMENT OF THE SYSTEM / REPORTING MEDIA.**

It is the clients/ end user's management team / operations manager or nominated person's responsibility to manage the CCTV system, retain recording of specific events (within the guidelines of the data protection act) set time profiles/ groups ETC and ensure that the network is kept in good working order so that the system can send notifications. Alpine Security cannot accept any responsibility for any notification failures as these are outside of our control.

**STANDBY POWER / BACK UP**

There has been no allowance for any standby batteries or UPS equipment to be fitted, the CCTV system will warm start in the event of power restored.

**WORKING HOURS**

This quotation is subject to installation being carried out during our normal working hours - Monday to Friday 9.00am to 5.00pm. It does not cover extraneous work, building work, carpet lifting, refitting or redecoration.

**SYSTEM CERTIFICATION**

The system will be certificated based on the system conforming to the SSAIB CCTV Code of Practice

**Acceptance**

**I agree to the installation of this security system as detailed above and have read and understand all parts**

Signed: ..... (Print name) ..... Date: .....  
(Customer's Signature)

**The system has been installed in accordance with the above specification.**

Signed:  ..... (Print name) **D Bates** ..... Date: **01/04/2022**  
(Engineer's Signature)

# DH-TPC-BF5601-T

## Thermal Network Bullet Camera

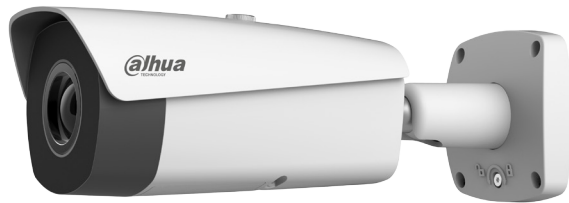

- 640 × 512 uncooled VOx thermal sensor technology
- Athermalized lens (thermal), focus-free
- Support temperature measurement
- Various lens optional (7.5/13/25 mm)
- 2/2 alarm in/out
- Micro SD memory, IP67, PoE, ePoE

### System Overview

Featuring a fixed lens bullet camera, this series provides an all-in-one solution that is especially beneficial for temperature measurement. Together with Thermal technology, the camera's long range capabilities are able to be utilized even at night.

### Functions

#### Uncooled VOx Technology

Dahua thermal cameras use uncooled VOx sensor technology. Their small size and better performance make them a cost-effective solution for thermal security.

#### High Sensitivity

High thermal sensitivity (< 40mK) makes cameras capture more image details and temperature difference information.

#### Temperature Measurement

Dahua thermal cameras (-T models) provide remote temperature monitoring functionality with the ability to set temperature threshold alarms. Object temperatures can be monitored in daytime or at night, making them ideal for usage in power plant or oil extraction applications where overheating can be dangerous. When the temperature exceeds the set threshold, an alarm is triggered. The temperature range is between -20 °C to 550 °C.

### Intelligent Video System (IVS)

IVS is a built-in video analytics algorithm that delivers intelligent functions to monitor a scene for tripwire violations, intrusion detection. A camera with IVS quickly and accurately responds to monitoring events in a specific area.

### Environmental

With a temperature range of -40 °C to +70 °C (-40 °F to +158 °F), the camera is designed for extreme temperature environments. Subjected and certified to rigorous dust and water immersion tests, the IP67 rating makes it suitable for demanding outdoor applications.

### Protection

The camera allows for wide input voltage tolerance, suitable for the most unstable conditions for outdoor applications. Its 6KV lightning rating provides effective protection for both the camera and its structure against lightning.



**Technical Specification**

|   |   |   |  |
|---|---|---|--|
| Thermal                                     |   |   |  |
| Detector Type                               | Vanadium Oxide Uncooled Focal Plane Detector                                  |   |  |
| Max. Resolution                             | 640 × 512   |   |  |
| Pixel Pitch                                 | 17µm  |   |  |
| Spectral Range                              | 8µm–14µm  |   |  |
| Thermal Sensitivity (NETD)                  | ≤ 40mK@f/1.0  |   |  |
| Focal Length                                | 7.5 mm  | 13 mm   | 25 mm  |
| Field of View                               | H: 91.2° ×<br>V: 70.3°  | H: 48.9° ×<br>V: 38.8°  | H: 24.6° ×<br>V: 19.8°   |
| Effective Distance<br>Human (1.8 m × 0.5 m) | D: 221 m<br>(725.07 ft)<br>R: 57 m<br>(187.01 ft)<br>I: 28 m<br>(91.86 ft)    | D: 382 m<br>(1253.28 ft)<br>R: 98 m<br>(321.52 ft)<br>I: 49 m<br>(160.76 ft)    | D: 735 m<br>(2411.42 ft)<br>R: 189 m<br>(620.08 ft)<br>I: 95 m<br>(311.68 ft)    |
|   | D: 558 m<br>(1830.71 ft)<br>R: 147 m<br>(482.28 ft)<br>I: 74 m<br>(242.78 ft) | D: 1020 m<br>(3346.47 ft)<br>R: 255 m<br>(836.61 ft)<br>I: 127 m<br>(416.67 ft) | D: 1961 m<br>(6433.73 ft)<br>R: 490 m<br>(1607.61 ft)<br>I: 245 m<br>(803.81 ft) |
|   | Focus Mode: Athermalized  |   |  |
| Aperture                                    | F1.0  |   |  |
| Digital Detail Enhancement (DDE)            | Yes   |   |  |
| Image Stabilization                         | Electronic Image Stabilization  |   |  |
| Digital Zoom                                | 24×   |   |  |
| AGC   | Auto; Manual  |   |  |
| Noise Reduction                             | 2D NR; 3D NR  |   |  |
| Image Flip                                  | 90°/180°/mirror   |   |  |

|                       |   |
|-----------------------|---|
| Intelligence          |   |
| Advanced Intelligence | Fire Detection & Alarm<br>Cold & Hot Spot Trace<br>Tripwire & Intrusion<br>Human & Vehicle Classification |

|                         |   |
|-------------------------|---|
| Temperature Measurement |   |
| Temperature Range       | Low Temperature Mode: -20°C to +150°C (-4°F to +302°F)<br>High Temperature Mode: 0°C to +550°C (+34°F to +1022°F) |
| Temperature Accuracy    | Max (±2°C, ±2%)<br>Operating Temperature: -20°C to +60°C (-4°F to +140°F)   |
| Temperature Mode        | Spot: 12<br>Line: 12<br>Area: 12<br>Support 12 rules simultaneously   |

|                   |   |
|-------------------|---|
| Video and Audio   |   |
| Video Compression | H.265/H.264M/H.264H/H.264B/MJPEG  |
| Resolution        | Main stream:<br>(1280 × 1024/1280 × 720/640 × 512/), 1280 × 1024 by default;<br>Sub stream: (640 × 512/320 × 256), 640 × 512 by default |

|                   |  |
|-------------------|--|
| Frame Rate        | 50Hz:<br>Main Stream: 1fps–25fps, 25fps by default; sub stream: 1fps–25fps, 15fps by default<br>60Hz:<br>Main Stream: 1fps–30fps, 30fps by default; sub stream: 1fps–30fps, 15fps by default |
| Audio Compression | G.711a; G.711mu; PCM   |

|                          |   |
|--------------------------|---|
| General Function         |   |
| Network Protocol         | HTTP; HTTPS; TCP; ARP; RTSP; RTP; UDP; RTCP; SMTP; FTP; DHCP; DNS; DDNS; PPPOE; IPv4/v6; SNMP; QoS; UPnP; NTP   |
| Region of Interest (ROI) | Yes   |
| Edge Storage             | FTP; Micro SD card (256G)   |
| Interoperability         | ONVIF; CGI; DAHUA SDK   |
| Browser                  | IE: IE9 and the later (Edge not support)<br>Google: 42 and the earlier<br>Firefox: 52 and the earlier           |
| User/Host                | 20 channels at most (the total bandwidth 64M)   |
| Security                 | Authorized username and password; attached MAC address; encrypted HTTPS; IEEE 802.1x; controlled network access |
| User Management          | Support 20 users at most and users are classified as two groups-administrator group and user group.             |
| Malfunction Detection    | Network disconnection; IP addresses conflict; SD card error (status or storage space)                           |

|                |         |
|----------------|---------|
| Certification  |         |
| Certifications | CE; FCC |

|                     |  |
|---------------------|--|
| Port                |  |
| Analog Video Output | 1 channel of CVBS output with BNC port |
| Network             | 1 10M/100M Ethernet port (RJ-45)       |
| Audio Input         | 1                                      |
| Audio Output        | 1                                      |
| Alarm Input         | 2                                      |
| Alarm Output        | 2                                      |
| RS-485              | 1 pair                                 |

|                   |  |
|-------------------|--|
| Power             |  |
| Power Supply      | 12V±20% DC, 1.2A, PoE (802.3af), ePoE                |
| Power Consumption | Basic: 5.0W<br>Maximum: 13W (power adapter excluded) |

|                       |   |
|-----------------------|---|
| Environment           |   |
| Operating Temperature | -40°C to +70°C (-40°F to +158°F)                            |
| Operating Humidity    | ≤ 95%   |
| Self-Adaptive         | Auto heating to protect the chip under the cold environment |

|                                  |  |
|----------------------------------|--|
| Physical Characteristics         |  |
| Protection Grade                 | IP67, anti-surge 6KV, anti-electrostatic 8KV (touched by objects), anti-electrostatic 15KV (air) |
| Product Dimensions (L × W × H)   | 291 mm × 103.7 mm × 97 mm (11.46" × 4.06" × 3.82")   |
| Packaging Dimensions (L × W × H) | 365 mm × 175 mm × 176 mm (14.37" × 6.89" × 6.93")  |

|               |                   |
|---------------|-------------------|
| Net Weight    | ≤1.4 kg (3.09 lb) |
| Gross Weight  | ≤1.9 kg (4.19 lb) |
| Lens          | Contained         |
| Power Adaptor | Selectable        |

**Dimensions (mm[inch])**

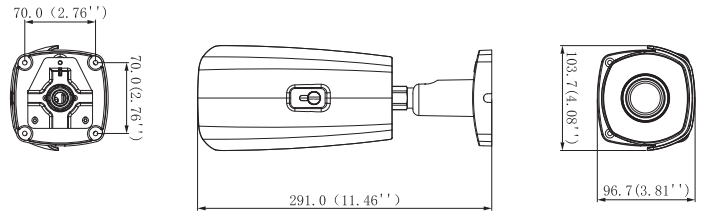

**Ordering Information**

| Type            | Model               | Description   |
|-----------------|---------------------|---|
| DH-TPC-BF5601-T | DH-TPC-BF5601P-TB7  | (with temperature measurement function)<br>Thermal: 640 × 512 7.5 mm lens |
|                 | DH-TPC-BF5601N-TB7  |   |
|                 | DH-TPC-BF5601P-TB13 | (with temperature measurement function)<br>Thermal: 640 × 512 13 mm lens  |
|                 | DH-TPC-BF5601N-TB13 |   |
|                 | DH-TPC-BF5601P-TB25 | (with temperature measurement function)<br>Thermal: 640 × 512 25 mm lens  |
|                 | DH-TPC-BF5601N-TB25 |   |

**Accessories**



DH-PFA121-V2

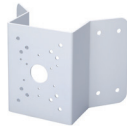

DH-PFA151



DH-PFA152-E

| Wall Mount | Corner Mount  | Pole Mount      |
|------------|---------------|-----------------|
| PFA121     | PFA121+PFA151 | PFA121+PFA152-E |
|            |               |                 |

## Appendix C

# SITE DAILY DIARY

|      |  |      |  |                |  |
|------|--|------|--|----------------|--|
| Site |  | Date |  | Author initial |  |
|------|--|------|--|----------------|--|

## Administration

|                    |                          |                          |                          |                          |                          |                          |
|--------------------|--------------------------|--------------------------|--------------------------|--------------------------|--------------------------|--------------------------|
| Weather            | Dry                      | Gentle rain              | Heavy rain               | Snow                     | Windy                    | Calm                     |
|                    | <input type="checkbox"/> | <input type="checkbox"/> | <input type="checkbox"/> | <input type="checkbox"/> | <input type="checkbox"/> | <input type="checkbox"/> |
| TCP presence       | Name                     |                          |                          | Hours                    |                          |                          |
| Environment Agency | Name                     |                          |                          | Time                     |                          |                          |
| Notable admin      |                          |                          |                          |                          |                          |                          |
| EA / CAR issue     |                          |                          |                          |                          |                          |                          |

## Waste operations

|   |  |
|---|--|
| Area of tipping                                 |  |
| Any unacceptable waste in quarantine / rejected |  |
| Plant issues                                    |  |

## Site inspection

| Site inspection  | Compliance | Any corrective action(s) |
|--|------------|--------------------------|
| 1. Pollution control (silt / oil storage / spill kit management) | Y / N      |                          |
| 2. Waste management  | Y / N      |                          |
| 3. Dust (see overleaf)   | Y / N      |                          |
| 4. Mud on road   | Y / N      |                          |
| 5. Litter  | Y / N      |                          |

## Other matters (or continuation from above)

|  |
|--|
|  |
|--|