

OPTION 2 WASH PLANT EQUIPMENT LIST	
PLANT ID:	PLANT DESCRIPTION:
1	H12 FEED HOPPER LIVE HEAD
2	AGGRESGRUB 150 WITH OVERSIZE
3	FINESMASTER 120 COMPACT 2G
4	GROUND SUMP PUMP
5	THICKENER - 12M
6	WATER TANK - 10M
7	FILTER PRESS
8	SLUDGE TANK
9	20FT CONTROL CABIN
10	FLOC CABIN
11	OVERBAND MAGNET
CONVEYOR EQUIPMENT LIST	
PLANT ID:	PLANT DESCRIPTION:
CV1	26m x 800mm STATIC FEED CONVEYOR
CV2	8m x 750mm RADIAL STOCKPILE CONVEYOR
CV3	8m x 750mm RADIAL STOCKPILE CONVEYOR
CV4	15m x 750mm RADIAL STOCKPILE CONVEYOR
CV5	18m x 750mm RADIAL STOCKPILE CONVEYOR
CV6	15m x 750mm RADIAL STOCKPILE CONVEYOR

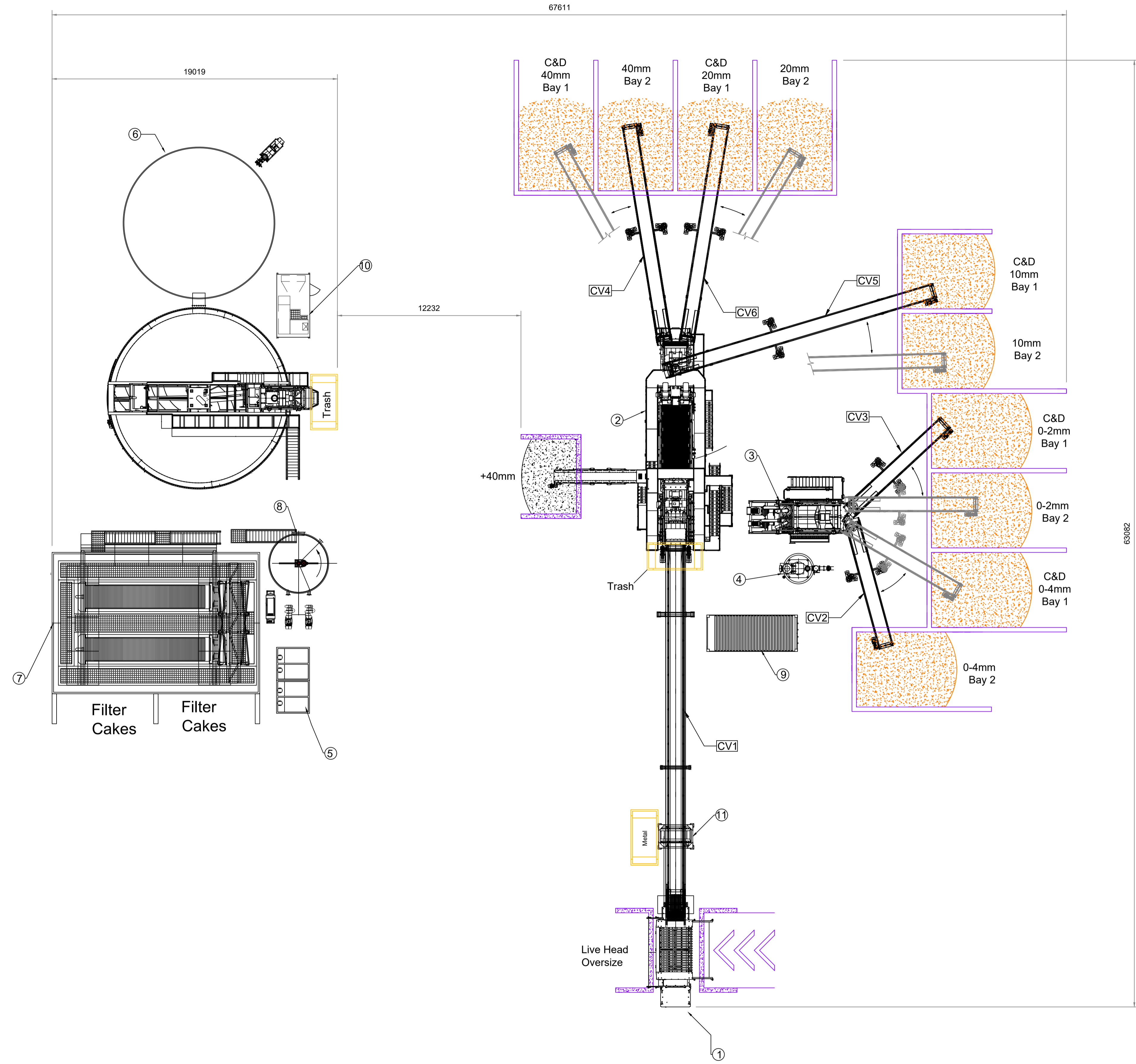

PowerX Equipment  
 Site 7 Meriden Park  
 Cornets End Lane  
 Meriden  
 CV7 7LG  
 T: 02476 405 100  
 www.pxequip.com

Revisions		Date:	Drawn by:	Checked by:
01	First Issue.	05/01/2022	T. Onisha	A. Sabel
Rev	Notes	Date:	Drawn by:	Checked by:

© THIS DOCUMENT IS THE COPYRIGHT OF POWERX EQUIPMENT LTD. IT MUST NOT BE LOANED, COPIED OR REPRODUCED WITHOUT THE WRITTEN PERMISSION OF THE COMPANY.		Site Ref:	Scale:
Notes:	Revision	Customer:	N.T.S.
	01	Blaxton Aggregates	Sheet No:
		Drawing No. E2185-SGA-001-01	1/1
		Description: General Arrangement	Sheet Size: A4

PLEASE NOTE THAT THIS IS A PRE-SALES DRAWING AND SHOULD BE USED FOR DISCUSSION / QUOTATION PURPOSES ONLY

ALL LEADING DIMENSIONS IN METRIC (mm). TRAILING DIMENSIONS IN IMPERIAL (ft, inch) UNLESS OTHERWISE STATED.



PowerX Equipment  
 Site 7 Meriden Park  
 Cornets End Lane  
 Meriden  
 CV7 7LG  
 T: 02476 405 100  
 www.pxequip.com

Revisions		Date	Drawn by	Checked by
01	First Issue	05/01/2022	T. Onisha	A. Sabel
Rev	Notes	Date	Drawn by	Checked by

© THIS DOCUMENT IS THE COPYRIGHT OF POWERX EQUIPMENT LTD. IT MUST NOT BE LOANED, COPIED OR REPRODUCED WITHOUT THE WRITTEN PERMISSION OF THE COMPANY.  
 Notes: --  
 Revision: 01

Site Ref:	Customer: Blaxton Aggregates	Scale: N.T.S.
Drawing No. E2185-SGA-001-02	Description: General Arrangement	Sheet No: 1/1
		Sheet Size: A4

**PLEASE NOTE THAT THIS IS A PRE-SALES DRAWING AND SHOULD BE USED FOR DISCUSSION / QUOTATION PURPOSES ONLY**

ALL LEADING DIMENSIONS IN METRIC (mm). TRAILING DIMENSIONS IN IMPERIAL (ft, inch) UNLESS OTHERWISE STATED.