

- NOTES**
- TANK TO BE MANUFACTURED i.a.w. BS 799 Pt 5 Type J
 - TANK TO BE MANUFACTURED FROM 6mm THICK STEEL TO S275JR BS EN 10025:2004.
 - TANK FINISH :-
 - ELECTRIC WIRE BRUSH (WHERE NECESSARY) & DEGREASE.
 - 1 COAT PRIMER.
 - 2 COATS OF AIR DRYING ENAMEL.
 - COLOUR - T.B.A.
 - MINIMUM PAINT THICKNESS (DFT) - 70um.
 - TANK CAPACITY - 18,000 Ltr NOMINAL, 21,666 Ltr BRIMFUL.
 - WEIGHT - 11.5 Tonnes (DRY), 29.5 Tonnes (WET).

- NOTES (CONTINUED)**
- WELDING TO BE CARRIED OUT i.a.w. BS EN 1011-1:2009 WITH REFERENCE TO BS EN 1011-2:2001.
 - WELDING SYMBOLS USED ARE i.a.w. BS EN ISO 22553.
 - INSPECTION & TESTING TO BE CARRIED OUT i.a.w. BS EN 1011-1:2009.
 - TESTING
 - TANK - 0.2 Bar.
 - BUND - 0.1 Bar MAX. TEST PRESSURE.
 - ISSUE TEST CERTIFICATE ON SUCCESSFUL COMPLETION.
 - CABLE TIE BARS TO BE INSTALLED AS STANDARD WHEN PUMPS AND/OR INSTRUMENTS ARE INSTALLED OUT WITH / WITHIN BUND.

Issue	Date	Comments	Drawn	Chkd.	Appd.
05	01/07/14	SHEETS 5 & 8 REVISED	A.M.	-	-
04	13/06/14	SOCKETS & MOUNTING POINTS REPOSITIONED	A.M.	-	-
03	05/06/14	INTERNAL BEAMS, TANK BEARERS AND MOUNTING PADS REPOSITIONED.	A.M.	-	-
02	16/05/14	TANK REDESIGNED	A.M.	-	-
01	07/04/14	DRAWING ISSUED FOR COMMENTS.	A.M.	T.K.	-

S. KORONKA (Manufacturing) LIMITED
 Bridgend, Kinross. KY13 8GB.
 Tel. :- 01577 862189
 Fax. :- 01577 864773
 Email :- sales@koronka.co.uk

Title
**21,666 Litre (BRIMFUL)
 BUNDED CLEAN OIL
 STORAGE TANK**

Customer Order No. A16254	Drawing Sheet No. SHEET 1 OF 11	Customer Account No. A0136
Material 6mm THK STEEL	Quantity Required 3	
Dimensions mm	Scale 1:35 OR AS STATED	Tolerance ±5mm
Drawing/Serial No. 032714	Sheet No. 001	Issue No. 005

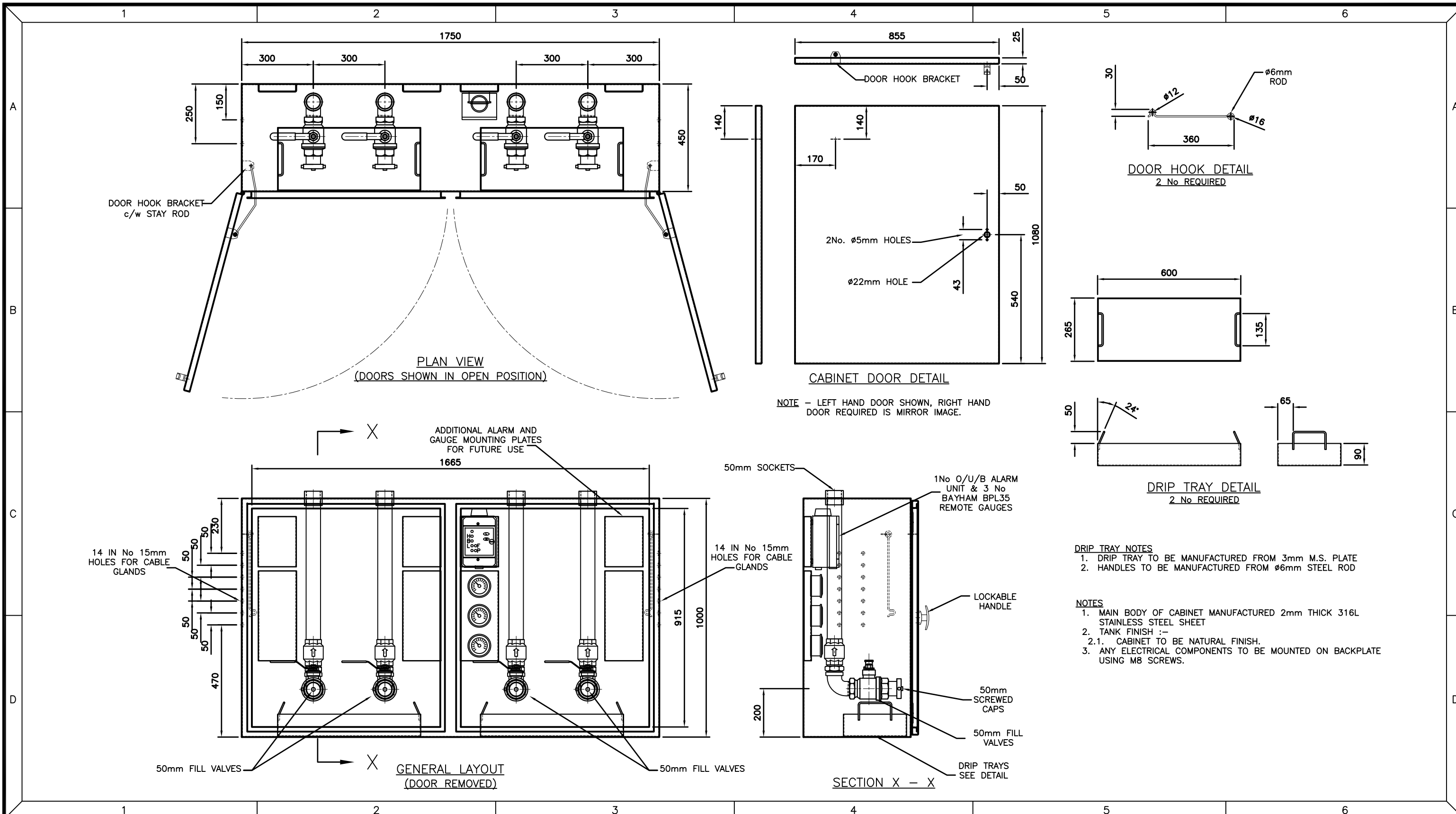

Issue	Date	Comments	Drawn	Chkd.	Appd.
05	01/07/14	SHEETS 5 & 8 REVISED	A.M.	-	-
04	13/06/14	ALRM & GAUGES REPOSITIONED	A.M.	-	-
03	05/06/14	SHEETS 1,2,5,8,10 & 11 REVISED	A.M.	-	-
02	16/05/14	CABINET REDESIGNED	A.M.	-	-
01	07/04/14	DRAWING ISSUED FOR COMMENTS.	A.M.	T.K.	-

S. KORONKA (Manufacturing) LIMITED
 Bridgend, Kinross. KY13 8GB.
 Tel. :- 01577 862189
 Fax. :- 01577 864773
 Email :- sales@koronka.co.uk

Title
**DETAIL OF QUADRUPLE
 FILL CABINET WITH 50mm
 FILL VALVES**

Customer Order No. A16254	Drawing Sheet No. SHEET 3 OF 11	Customer Account No. A0136
Material SEE NOTES	Quantity Required 1	
Dimensions mm	Scale 1:15 OR AS STATED	Tolerance ± 5 mm
Drawing/Serial No. 032714	Sheet No. 003	Issue No. 005

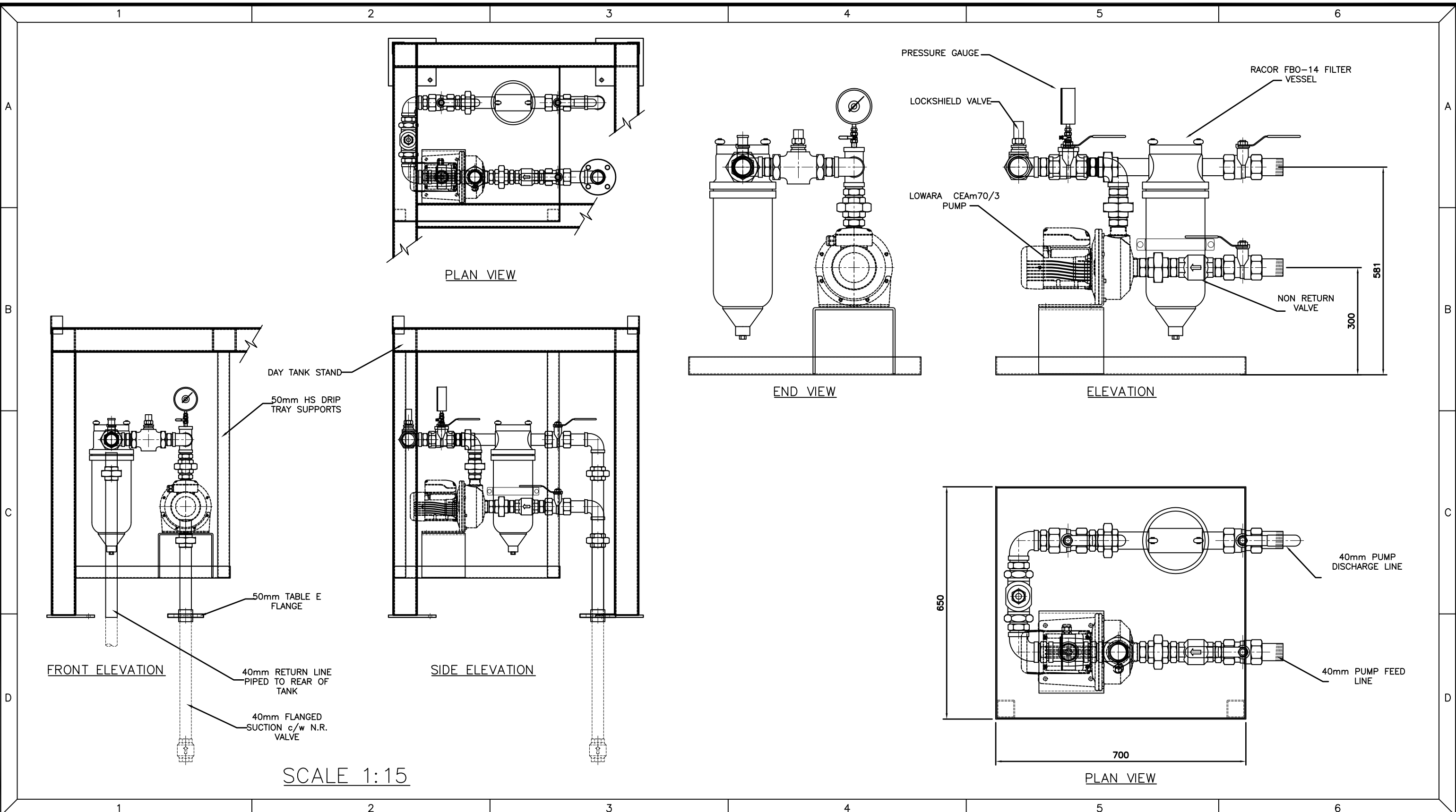

Issue	Date	Comments	Drawn	Chkd.	Appd.
05	01/07/14	SHEETS 5 & 8 REVISED	A.M.	--	--
04	13/06/14	SHEETS 1,2,3,7,8,10 & 11 REVISED	A.M.	--	--
03	05/06/14	SHEETS 1,2,5,8,10 & 11 REVISED	A.M.	--	--
02	16/05/14	POLISHING UNIT REDESIGNED & REPOSITIONED	A.M.	--	--
01	07/04/14	DRAWING ISSUED FOR COMMENTS.	A.M.	T.K.	--

Client's Project Ref:	Approved By:	Date:	Customer:
SOUTHALL, HAYES	A J POWER	07/04/2014	A J POWER

S. KORONKA (Manufacturing) LIMITED
 Bridgend, Kinross. KY13 8GB.
 Tel. :- 01577 862189
 Fax. :- 01577 864773
 Email :- sales@koronka.co.uk

Title
DETAIL OF FUEL POLISHING SYSTEM

Customer Order No. A16254	Drawing Sheet No. SHEET 4 OF 11	Customer Account No. A0136
Material SEE NOTES		Quantity Required 3
Dimensions mm	Scale 1:10 OR AS STATED	Tolerance ±5mm
Drawing/Serial No. 032714	Sheet No. 004	Issue No. 005

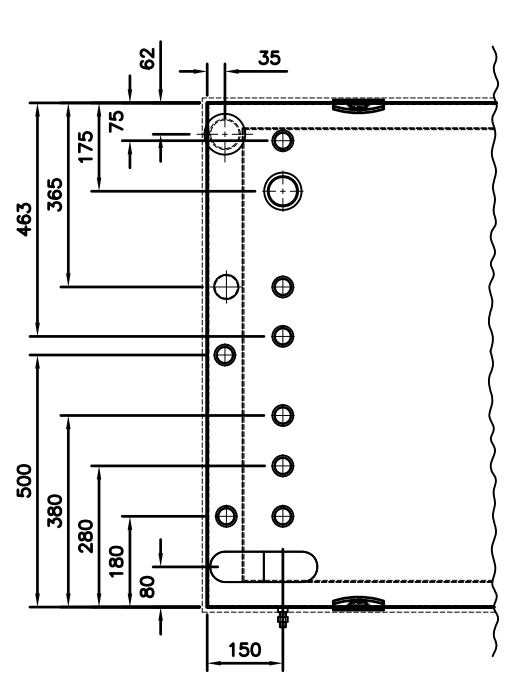

TANK TOP PENS.

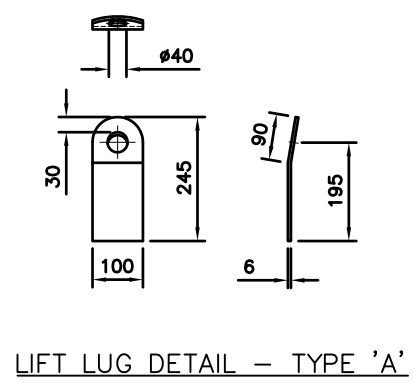

LIFT LUG DETAIL - TYPE 'A'

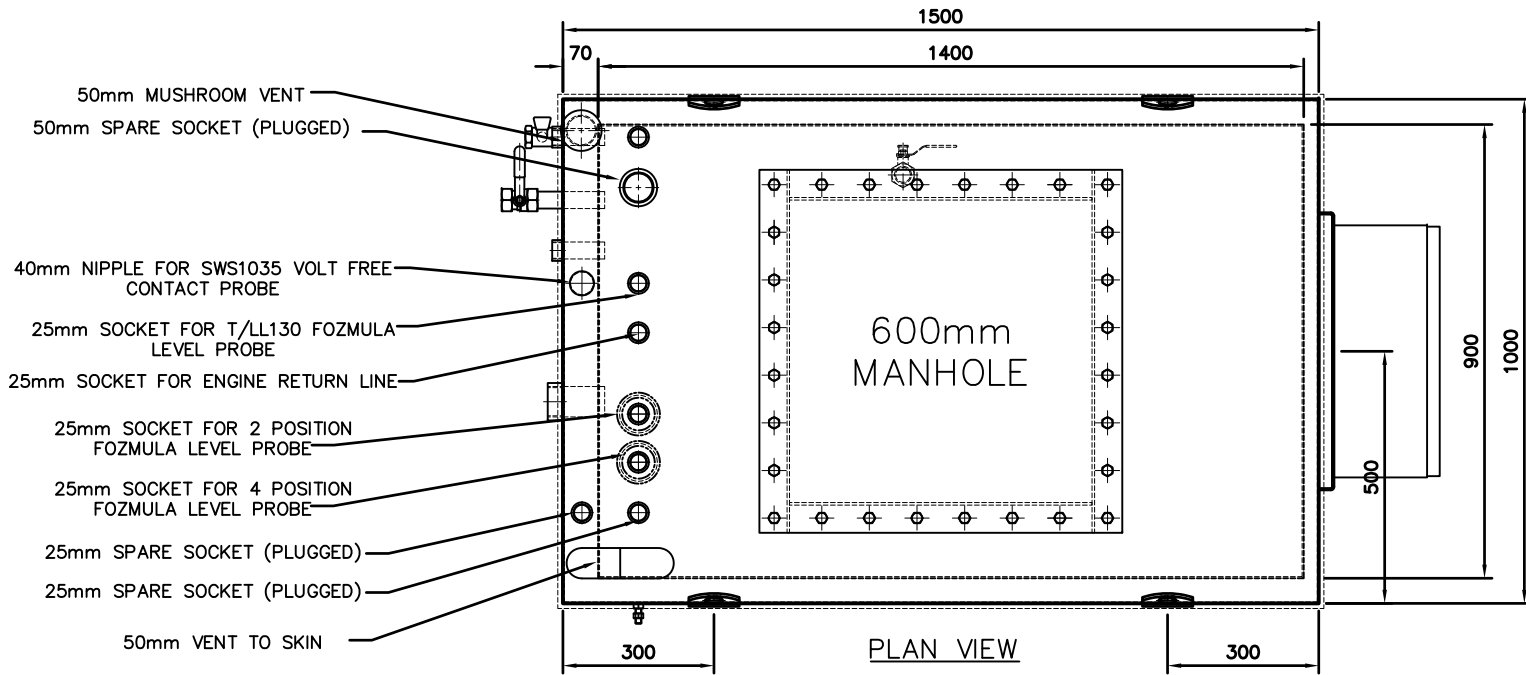

600mm
MANHOLE

PLAN VIEW

- NOTES**
- TANK TO BE MANUFACTURED i.a.w. BS 799 Pt 5 Type J
 - TANK TO BE MANUFACTURED FROM 3mm THICK STEEL TO S275JR BS EN 10025:2004.
 - TANK FINISH :-
 - ELECTRIC WIRE BRUSH (WHERE NECESSARY) & DEGREASE.
 - 1 COAT PRIMER.
 - 2 COATS OF AIR DRYING ENAMEL.
 - COLOUR - T.B.A.
 - MINIMUM PAINT THICKNESS (DFT) - 70um.
 - TANK CAPACITY - 1,200 Ltr NOMINAL, 1,350 Ltr BRIMFUL.
 - WEIGHT - 0.5 Tonnes (DRY), 1.4 Tonnes (WET).
 - WELDING TO BE CARRIED OUT i.a.w. BS EN 1011-1:2009 WITH REFERENCE TO BS EN 1011-2:2001.
 - WELDING SYMBOLS USED ARE i.a.w. BS EN ISO 22553.
 - INSPECTION & TESTING TO BE CARRIED OUT i.a.w. BS EN 1011-1:2009.
 - TESTING
 - TANK - 0.2 Bar.
 - BUND - 0.1 Bar MAX. TEST PRESSURE.
 - ISSUE TEST CERTIFICATE ON SUCCESSFUL COMPLETION.
 - CABLE TIE BARS TO BE INSTALLED AS STANDARD WHEN PUMPS AND/OR INSTRUMENTS ARE INSTALLED ON TANK

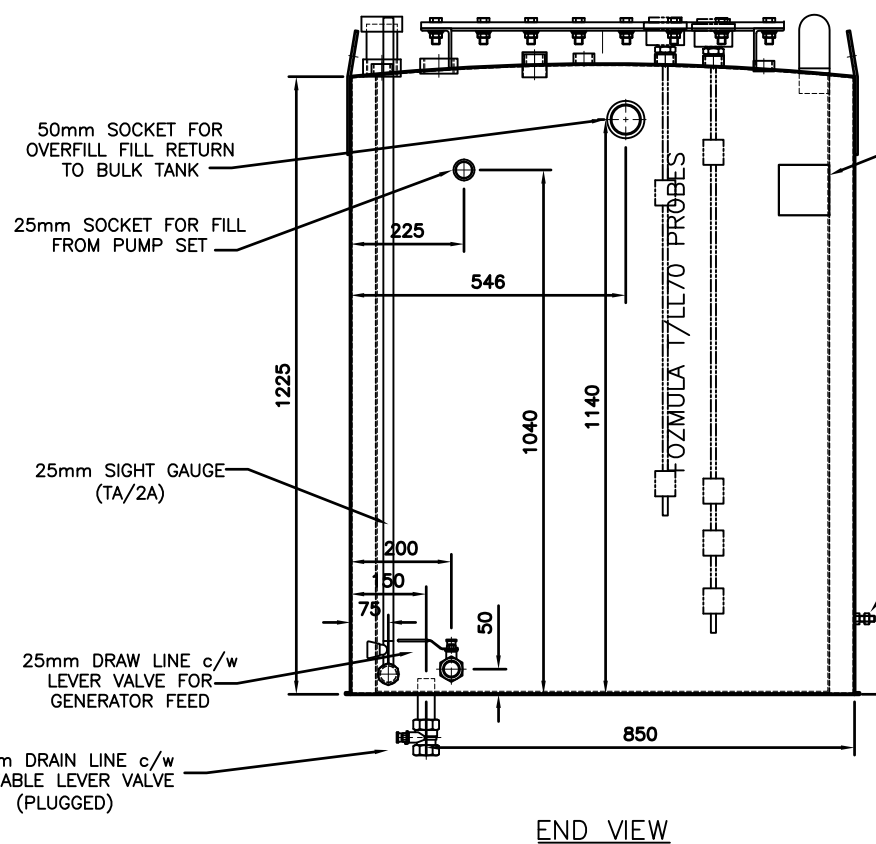

END VIEW

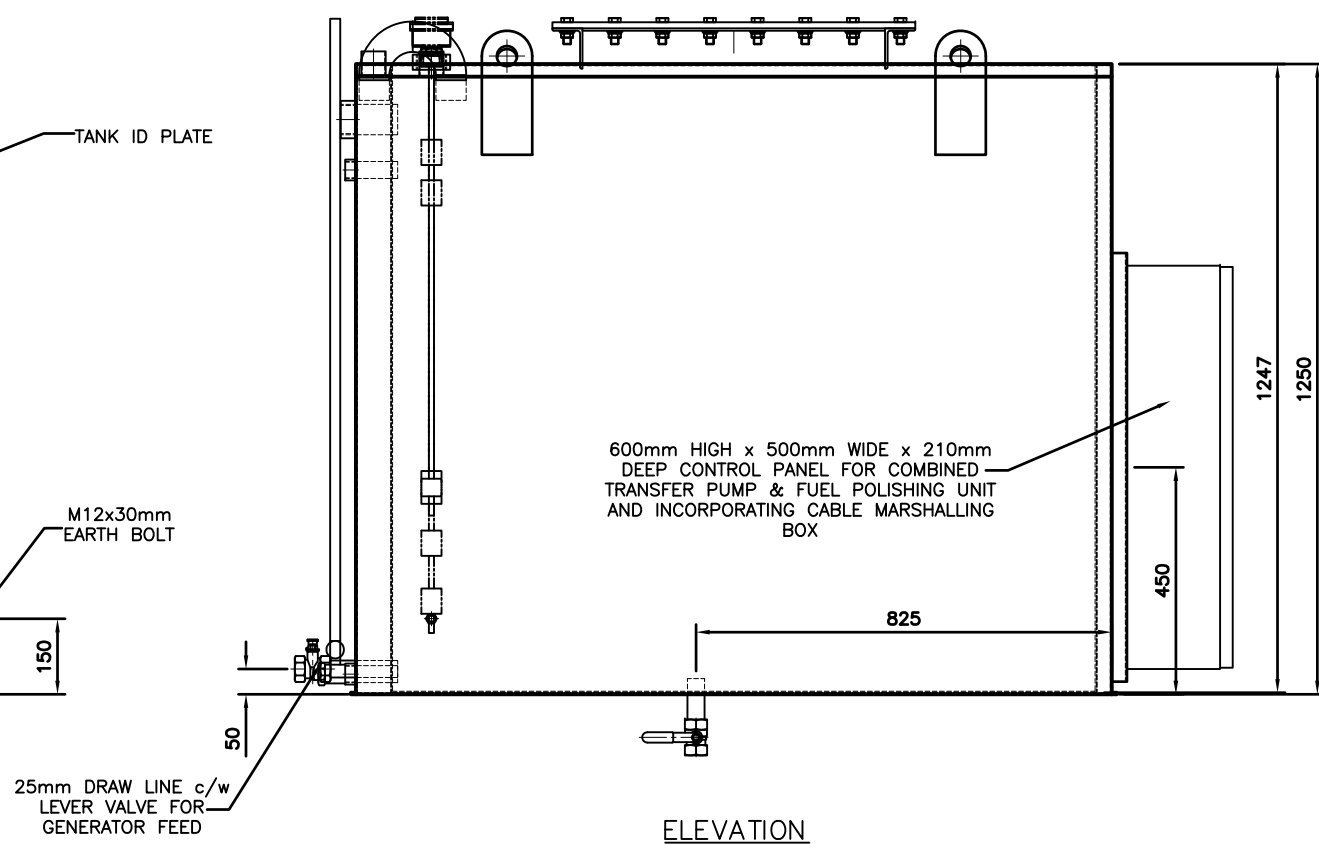

ELEVATION

Issue	Date	Comments	Drawn	Chkd.	Appd.
05	01/07/14	TANK CONNECTIONS REPOSITIONED.	A.M.	-	-
04	13/06/14	SHEETS 1,2,3,7,8,10 & 11 REVISED	A.M.	-	-
03	05/06/14	OCIO GAUGE & SUCTION LINE REMOVED	A.M.	-	-
02	16/05/14	TANK REDESIGNED	A.M.	-	-
01	07/04/14	DRAWING ISSUED FOR COMMENTS.	A.M.	T.K.	-

S. KORONKA (Manufacturing) LIMITED
 Bridgend, Kinross. KY13 8GB.
 Tel. :- 01577 862189
 Fax. :- 01577 864773
 Email :- sales@koronka.co.uk

Title
**1350 Litre (BRIMFUL)
 BUNDED CLEAN OIL
 STORAGE TANK**

Customer Order No. A16254	Drawing Sheet No. SHEET 5 OF 11	Customer Account No. A0136
Material 3mm THK STEEL	Quantity Required 3	
Dimensions mm	Scale 1:20 OR AS STATED	Tolerance ±5mm
Drawing/Serial No. 032714	Sheet No. 005	Issue No. 005

Client's Project Ref: SOUTHALL, HAYES	Approved By: A J POWER	Date: 07/04/2014	Customer: A J POWER
---	---------------------------	---------------------	-------------------------------

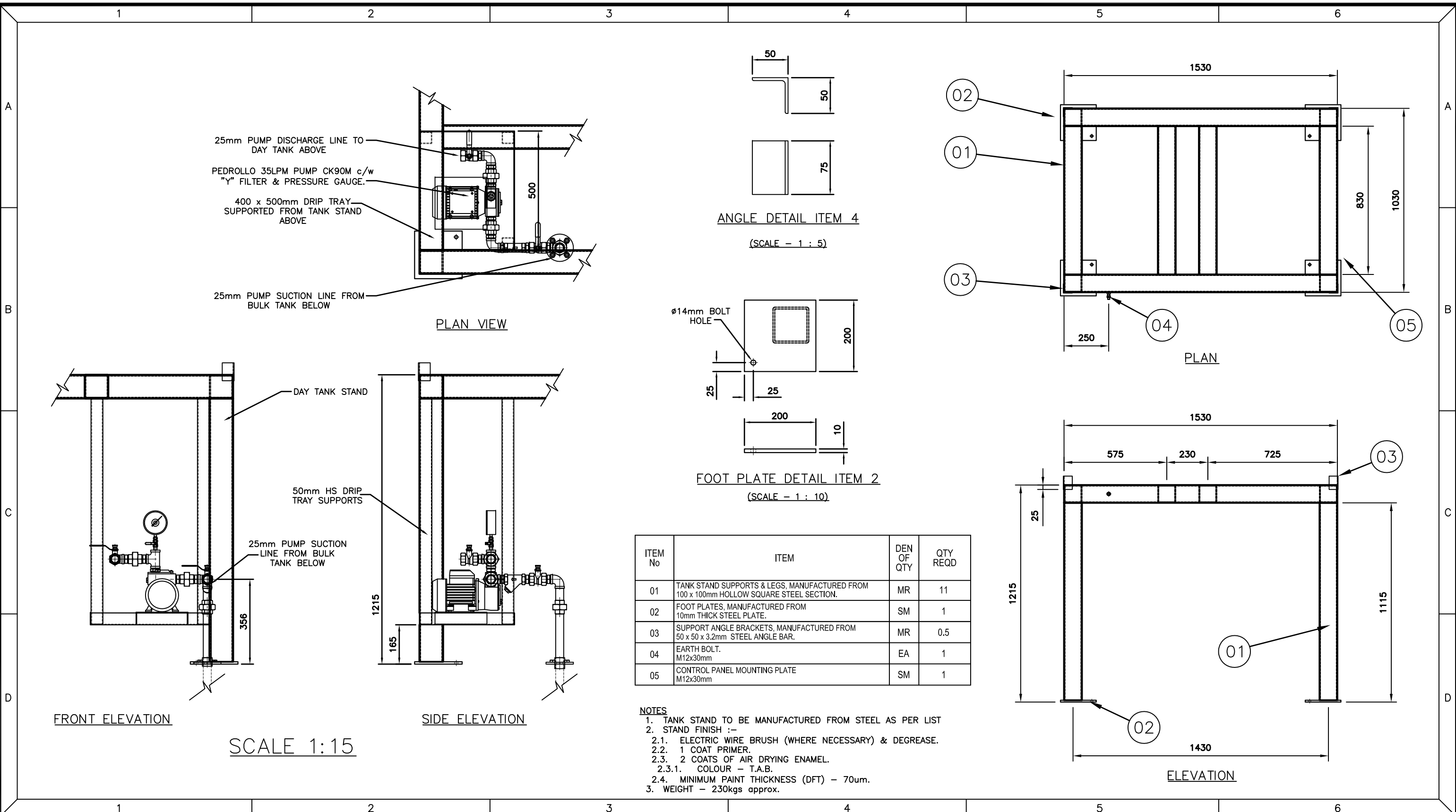

Issue	Date	Comments	Drawn	Chkd.	Appd.
05	01/07/14	SHEETS 5 & 8 REVISED	A.M.	-	-
04	13/06/14	SHEETS 1,2,3,7,8,10 & 11 REVISED	A.M.	-	-
03	05/06/14	SHEETS 1,2,5,8,10 & 11 REVISED	A.M.	-	-
02	16/05/14	STAND REVISED TO SUIT REVISED TANK DESIGN	A.M.	-	-
01	07/04/14	DRAWING ISSUED FOR COMMENTS.	A.M.	T.K.	-

S. KORONKA (Manufacturing) LIMITED
 Bridgend, Kinross. KY13 8GB.
 Tel. :- 01577 862189
 Fax. :- 01577 864773
 Email :- sales@koronka.co.uk

Title
**TANK STAND FOR
 1350 Litre BUNDED OIL
 TANK - 1215mm HIGH c/w
 PEDROLLO PUMP SET**

Customer Order No. A16254	Drawing Sheet No. SHEET 6 OF 11	Customer Account No. A0136
Material AS PER TABLE		Quantity Required 3
Dimensions mm	Scale 1:20 OR AS STATED	Tolerance ±5mm
Drawing/Serial No. 032714	Sheet No. 006	Issue No. 005

NOTES

1. STAIRS TO BE BOLTED TO LUGS WELDED TO TANKS
2. PLATFORM & STEPS TO BE MANUFACTURED i.a.w. BS 5395-1:2000
3. STEPS & ASSOCIATED RAILS TO BE HOT DIP GALVANISED TO ISO 1461 ON COMPLETION OF MANUFACTURE.

50x10 FLAT BAR FULLY WELDED TO TANK ROOF. FINISH AS PER TANK

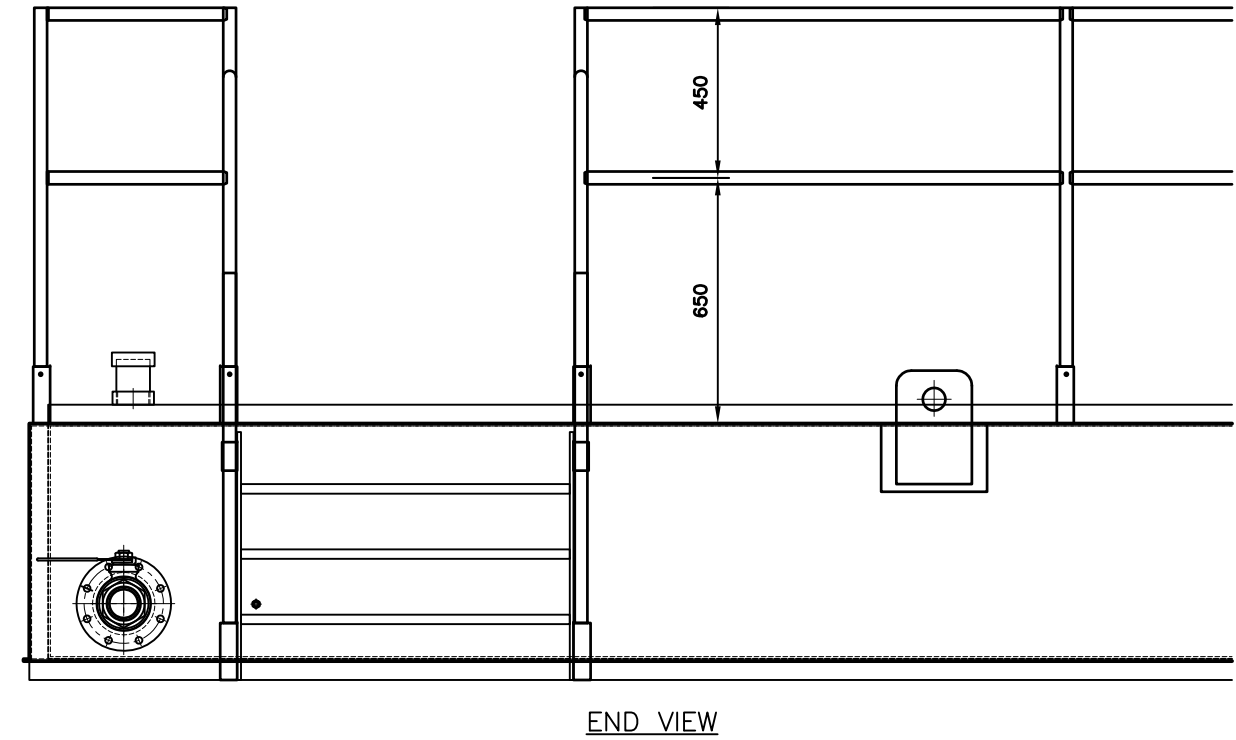
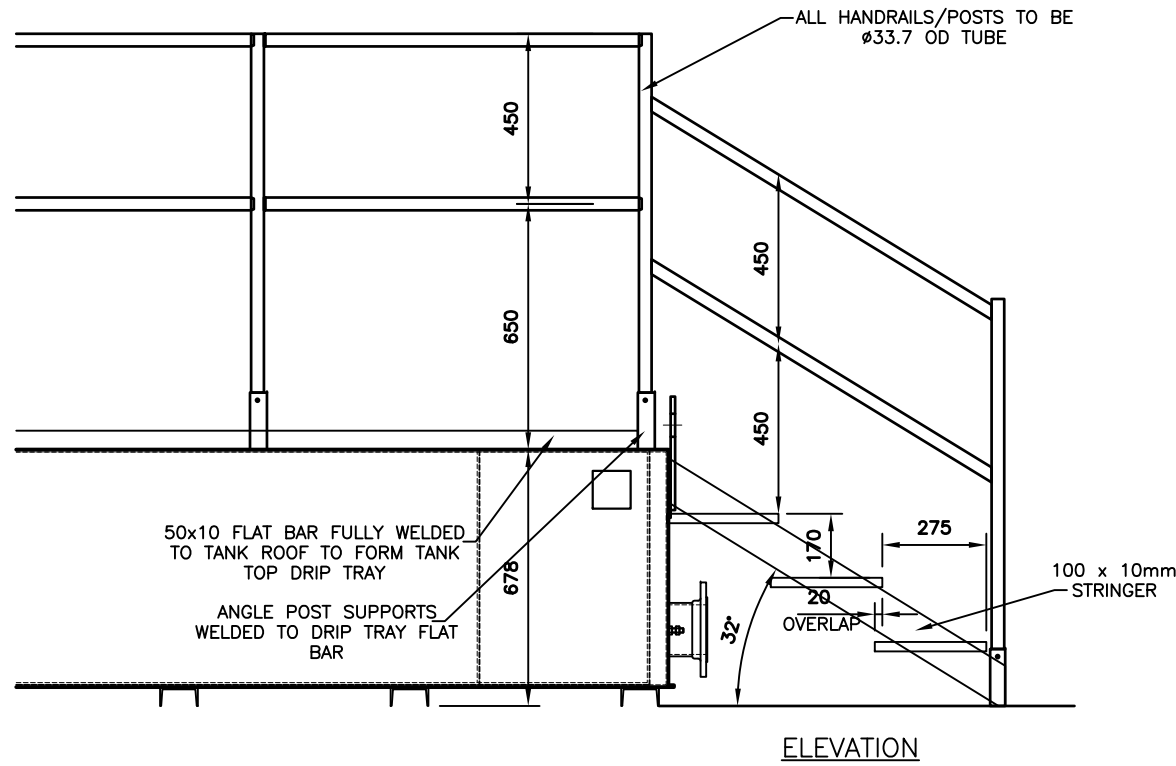
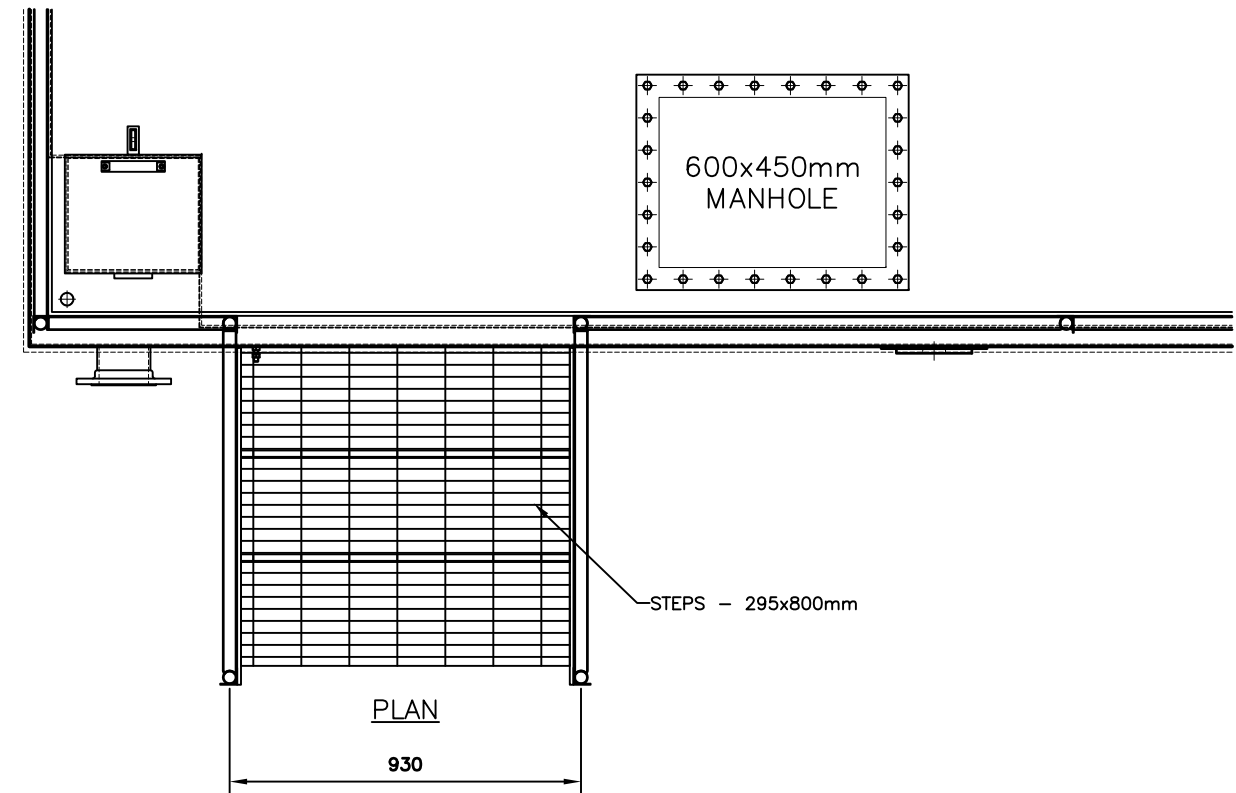

Issue	Date	Comments	Drawn	Chkd.	Appd.
05	01/07/14	SHEETS 5 & 8 REVISED	A.M.	-	-
04	13/06/14	SOCKETS & MOUNTING POINTS REPOSITIONED	A.M.	-	-
03	05/06/14	SHEETS 1,2,5,8,10 & 11 REVISED	A.M.	-	-
02	16/05/14	STAIR REDESIGNED & REPOSITIONED	A.M.	-	-
01	07/04/14	DRAWING ISSUED FOR COMMENTS.	A.M.	T.K.	-



S. KORONKA (Manufacturing) LIMITED
 Bridgend, Kinross. KY13 8GB.
 Tel. :- 01577 862189
 Fax. :- 01577 864773
 Email :- sales@koronka.co.uk

Title
**FIXED PLATFORM FOR
 21,666 Litre (BRIMFUL)
 BUNDED CLEAN OIL
 STORAGE TANK**

Customer Order No. A16254	Drawing Sheet No. SHEET 7 OF 11	Customer Account No. A0136
Material SEE NOTES	Quantity Required 1	
Dimensions mm	Scale 1:20 OR AS STATED	Tolerance ±5mm
Drawing/Serial No. 032714	Sheet No. 007	Issue No. 005

Clients Project Ref: SOUTHALL, HAYES	Approved By A J POWER	Date 07/04/2014	Customer A J POWER
--	--------------------------	--------------------	------------------------------

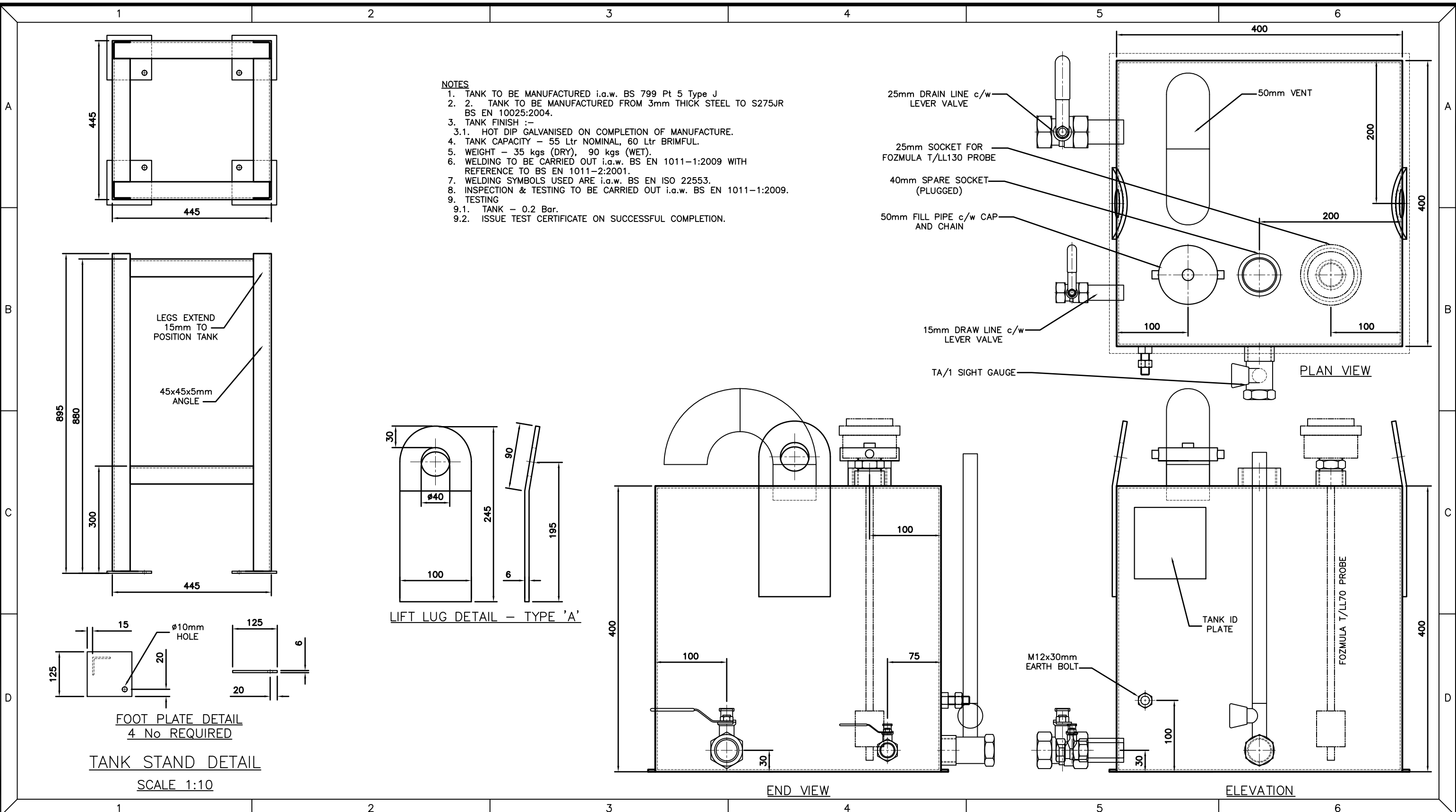

- NOTES**
1. TANK TO BE MANUFACTURED i.a.w. BS 799 Pt 5 Type J
 2. TANK TO BE MANUFACTURED FROM 3mm THICK STEEL TO S275JR BS EN 10025:2004.
 3. TANK FINISH :-
3.1. HOT DIP GALVANISED ON COMPLETION OF MANUFACTURE.
 4. TANK CAPACITY - 55 Ltr NOMINAL, 60 Ltr BRIMFUL.
 5. WEIGHT - 35 kgs (DRY), 90 kgs (WET).
 6. WELDING TO BE CARRIED OUT i.a.w. BS EN 1011-1:2009 WITH REFERENCE TO BS EN 1011-2:2001.
 7. WELDING SYMBOLS USED ARE i.a.w. BS EN ISO 22553.
 8. INSPECTION & TESTING TO BE CARRIED OUT i.a.w. BS EN 1011-1:2009.
 9. TESTING
9.1. TANK - 0.2 Bar.
9.2. ISSUE TEST CERTIFICATE ON SUCCESSFUL COMPLETION.

Issue	Date	Comments	Drawn	Chkd.	Appd.
05	01/07/14	SHEETS 5 & 8 REVISED	A.M.	-	-
04	13/06/14	SHEETS 1,2,3,7,8,10 & 11 REVISED	A.M.	-	-
03	05/06/14	SHEETS 1,2,5,8,10 & 11 REVISED	A.M.	-	-
02	16/05/14	CONNECTIONS & STAND ADDED	A.M.	-	-
01	07/04/14	DRAWING ISSUED FOR COMMENTS.	A.M.	T.K.	-

S. KORONKA (Manufacturing) LIMITED
 Bridgend, Kinross. KY13 8GB.
 Tel. :- 01577 862189
 Fax. :- 01577 864773
 Email :- sales@koronka.co.uk

Title
**60 Litre (BRIMFUL)
 SINGLE SKIN LUBE OIL
 STORAGE TANK
 c/w TANK STAND**

Customer Order No. A16254	Drawing Sheet No. SHEET 9 OF 11	Customer Account No. A0136
Material 3mm THK STEEL	Quantity Required 1	
Dimensions mm	Scale 1:5 OR AS STATED	Tolerance ±5mm
Drawing/Serial No. 032714	Sheet No. 009	Issue No. 005

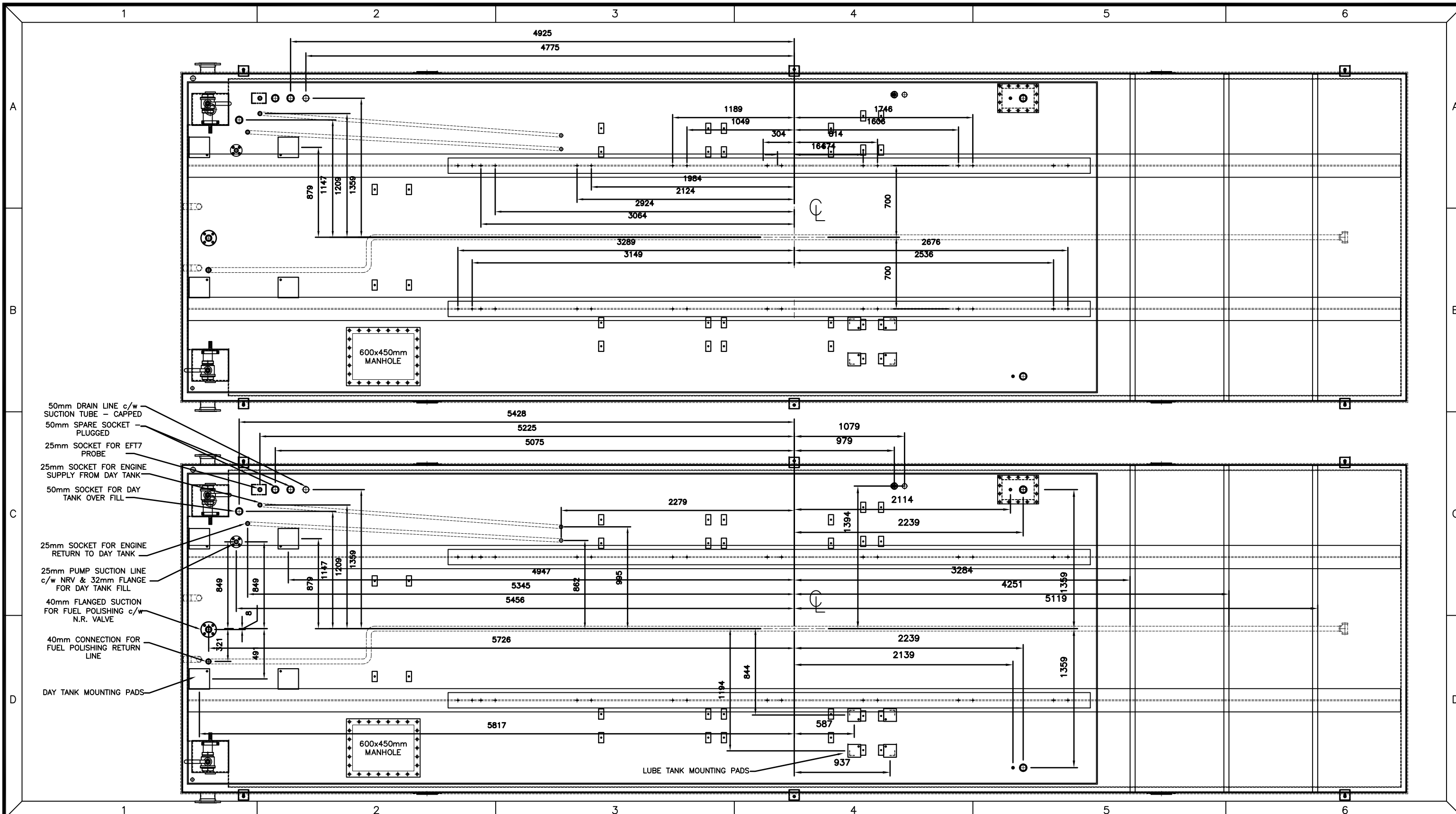

Issue	Date	Comments	Drawn	Chkd.	Appd.
05	01/07/14	SHEETS 5 & 8 REVISED	A.M.	-	-
04	13/06/14	SOCKETS & MOUNTING POINTS REPOSITIONED	A.M.	-	-
03	05/06/14	INTERNAL BEAMS, TANK BEARERS AND MOUNTING PADS REPOSITIONED.	A.M.	-	-
02	16/05/14	DRAWING ISSUED FOR COMMENTS.	A.M.	T.K.	-

S. KORONKA (Manufacturing) LIMITED
 Bridgend, Kinross. KY13 8GB.
 Tel. :- 01577 862189
 Fax. :- 01577 864773
 Email :- sales@koronka.co.uk

Title
**21,666 Litre (BRIMFUL)
 BUNDED CLEAN OIL
 STORAGE TANK
 SETTING OUT (SHEET 001)**

Customer Order No. A16254	Drawing Sheet No. SHEET 10 OF 11	Customer Account No. A0136
Material 6mm THK STEEL	Quantity Required 3	
Dimensions mm	Scale 1:35 OR AS STATED	Tolerance ±5mm
Drawing/Serial No. 032714	Sheet No. 010	Issue No. 005

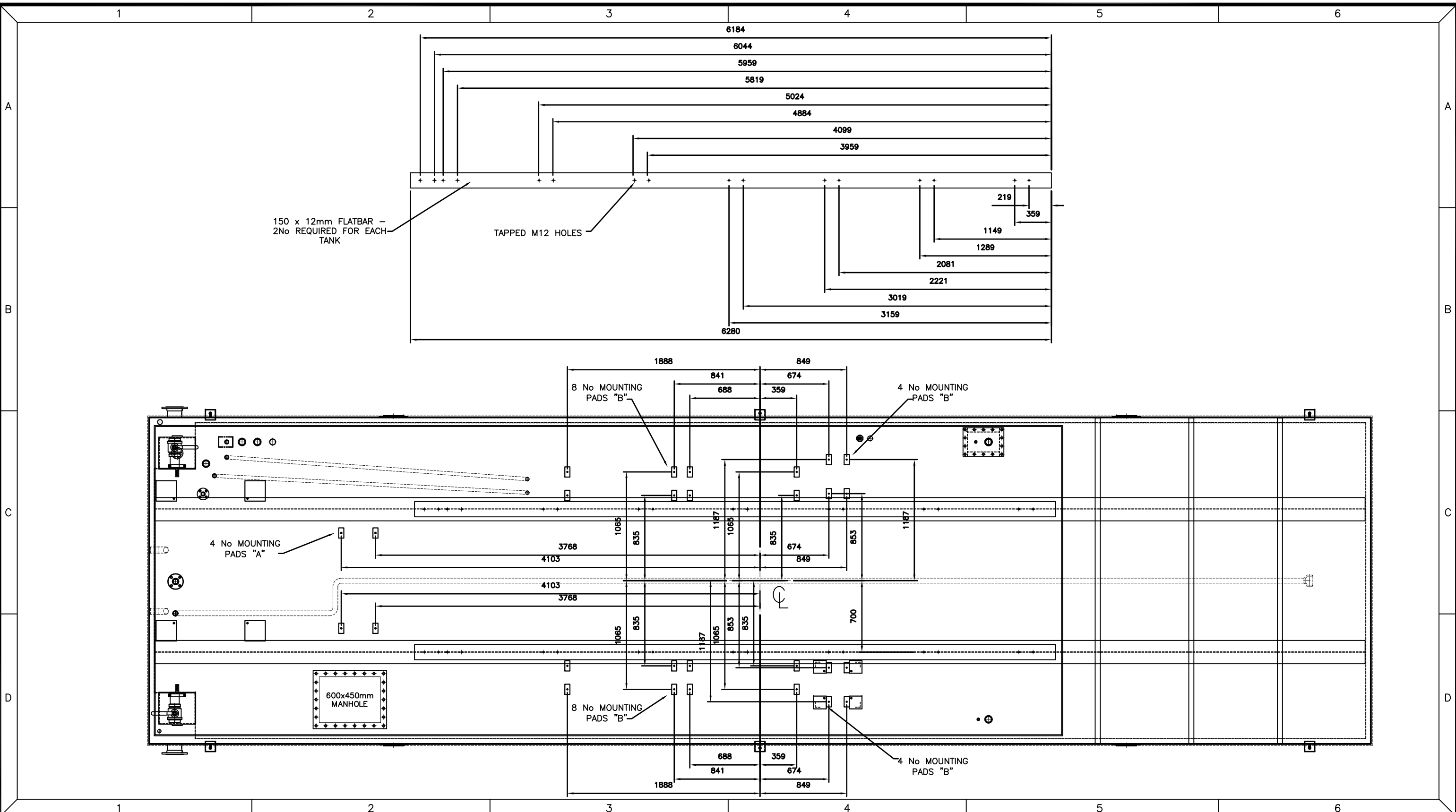

Issue	Date	Comments	Drawn	Chkd.	Appd.
05	01/07/14	SHEETS 5 & 8 REVISED	A.M.	-	-
04	13/06/14	SOCKETS & MOUNTING POINTS REPOSITIONED	A.M.	-	-
03	05/06/14	DRAWING ISSUED FOR COMMENTS.	A.M.	T.K.	-

Client's Project Ref:	Approved By	Date	Customer
SOUTHALL, HAYES	A J POWER	16/05/2014	A J POWER



S. KORONKA (Manufacturing) LIMITED
 Bridgend, Kinross. KY13 8GB.
 Tel. :- 01577 862189
 Fax. :- 01577 864773
 Email :- sales@koronka.co.uk

Title
**21,666 Litre (BRIMFUL)
 BUNDED CLEAN OIL
 STORAGE TANK
 SETTING OUT (SHEET 002)**

Customer Order No. A16254	Drawing Sheet No. SHEET 11 OF 11	Customer Account No. A0136
Material 6mm THK STEEL	Quantity Required 3	
Dimensions mm	Scale 1:35 OR AS STATED	Tolerance ±5mm
Drawing/Serial No. 032714	Sheet No. 011	Issue No. 005