



WASTE MANAGEMENT

# DERWENT RECYCLING CENTRE

## FIRE PREVENTION PLAN

18 Mar 2025 (V0.6)

### DISCLAIMER

No part of this document may be copied or reproduced without the prior written approval of H.W Martin Waste Limited.

# FIRE PREVENTION PLAN

## TABLE OF CONTENTS

<b>1.</b>	<b>INTRODUCTION</b> .....	<b>3</b>
<b>2.</b>	<b>SITE LOCATION</b> .....	<b>3</b>
	2.2 Sensitive Receptors .....	4
	2.3 Meteorological Conditions.....	5
<b>3.</b>	<b>WASTE ACTIVITIES</b> .....	<b>6</b>
	3.2 Site Infrastructure and Security.....	8
<b>4.</b>	<b>WASTE ACCEPTANCE, STORAGE AND REJECTION</b> .....	<b>9</b>
<b>5.</b>	<b>MANAGING THE COMMON CAUSES OF FIRE</b> .....	<b>12</b>
	5.1 Arson or vandalism .....	12
	5.2 Plant & equipment.....	12
	5.3 Electrical faults including damaged or exposed electrical cables .....	13
	5.4 Discarded smoking materials .....	14
	5.5 Hot works .....	14
	5.6 Industrial heaters.....	14
	5.7 Hot exhausts .....	14
	5.8 Ignition sources .....	14
	5.9 Batteries in ELVs.....	15
	5.10 Leaks and spillages of oils and fuels .....	15
	5.11 Build-up of loose combustible waste, dust and fluff .....	15
	5.12 Reactions between wastes .....	15
	5.13 Deposited hot loads .....	16
	5.14 Hot & dry weather .....	14
<b>6.</b>	<b>PREVENTION OF SELF COMBUSTION</b> .....	<b>17</b>
	6.1 Management of storage times .....	17
	6.2 Monitoring and control of temperature .....	18
<b>7.</b>	<b>MANAGING WASTE IN BAYS</b> .....	<b>19</b>
<b>8.</b>	<b>PREVENTION OF FIRE SPREADING</b> .....	<b>19</b>
	8.1 Waste Storage – Separation Distances .....	19
<b>9.</b>	<b>QUARANTINE AREA</b> .....	<b>20</b>
<b>10.</b>	<b>FIRE DETECTION</b> .....	<b>21</b>
<b>11.</b>	<b>FIRE SUPPRESSION</b> .....	<b>20</b>
<b>12.</b>	<b>FIREFIGHTING TECHNIQUES</b> .....	<b>25</b>
<b>13.</b>	<b>WATER SUPPLIES</b> .....	<b>27</b>
<b>14.</b>	<b>MANAGING FIRE WATER</b> .....	<b>28</b>
<b>15.</b>	<b>INCIDENT MANAGEMENT</b> .....	<b>30</b>
<b>16.</b>	<b>REVIEW OF THE FIRE PREVENTION PLAN</b> .....	<b>32</b>
<b>17.</b>	<b>FIRE PREVENTION PLAN SUMMARY</b> .....	<b>29</b>

## **TABLES**

<b>Table 1</b>	<b>Summary of Sensitive Receptors</b>
<b>Table 2</b>	<b>Site Activities</b>
<b>Table 3</b>	<b>Site CCTV</b>
<b>Table 4</b>	<b>Waste Storage</b>
<b>Table 5</b>	<b>Temperature Monitoring Trigger Levels</b>
<b>Table 6</b>	<b>Fire Water Containment</b>

## **DRAWINGS**

<b>DRC-FPP-001</b>	<b>DRC, Sensitive Receptors Plan, 14/12/2023</b>
<b>DRC-FPP-002</b>	<b>DRC, Site Drainage Plan, 28/06/2024</b>
<b>DRC-FPP-003</b>	<b>DRC, Traffic Management Plan, 14/08/2024</b>
<b>DRC-FPP-004</b>	<b>DRC, CCTV Plan, 07/08/2024</b>
<b>DRC-FPP-005</b>	<b>DRC, Material Bay Plan, 18/03/2025</b>
<b>DRC-FPP-007</b>	<b>DRC, Fire &amp; Rescue Service Location Plan, 23/01/2024</b>
<b>DRC-FPP-008</b>	<b>DRC, Firewater Retention Plan, 28/06/2024</b>
<b>DRC-FPP-009</b>	<b>DRC, Fire Prevention Plan, 17/03/2025</b>

## **APPENDICES**

<b>Appendix 1</b>	<b>Waste storage</b>
<b>Appendix 2</b>	<b>LDX thermal imaging camera</b>
<b>Appendix 3</b>	<b>Management procedures / systems</b>
	- <b>Daily / weekly checksheet</b>
	- <b>Mobile plant check sheet (traffic light system)</b>
	- <b>Permit to work</b>
	- <b>Mobile plant maintenance records</b>
	- <b>Waste acceptance procedure</b>
<b>Appendix 4</b>	<b>Concrete structural information</b>
<b>Appendix 5</b>	<b>Stratos Aspiration Smoke Detection system</b>
<b>Appendix 6</b>	<b>Angloco Mist-Tech VMS 2000 firefighting system</b>
<b>Appendix 7</b>	<b>PAT testing evidence</b>
<b>Appendix 8</b>	<b>Concrete interlocking blocks</b>

## 1. INTRODUCTION

- 1.1.1 This Fire Prevention Plan has been generated by H W Martin Waste Limited (hereafter referred to as HWMW) who operate a Household, Commercial and Industrial Waste Transfer Station, operating under a bespoke environmental permit (Reference EPR/VP3693VS, waste management licence number 65262) HWMW are planning to vary the permit to include baling as an option in the future, to extend the permit boundary and to increase the permitted tonnage.
- 1.1.2 As the site includes the storage of some combustible wastes, a Fire Prevention Plan is required to help (i) minimise the likelihood of a fire occurring or spreading, (ii) contain a fire so that it can be extinguished and (iii) to minimise the spread of fire within the site and to neighbouring sites.
- 1.1.3 The Fire Prevention Plan will form part of the Management System for the site, and it will be integrated into the system as a formal document. A copy of the plan will be kept on site, enabling ease of reference by site staff.
- 1.1.4 This Fire Prevention Plan has been written following consultation with the following EA guidance documents:
- Fire prevention plans: environmental permits
  - Fire prevention plan template
  - Fire prevention plans: case study examples of alternate measures
- 1.1.5 Mixed waste and segregated waste materials are delivered into the transfer station by HWMW, Local Authority and third party contractors. Segregated materials are predominantly bulked for onward transfer.

## 2. SITE LOCATION

- 2.1.1 The site covers approximately 2.03 hectares or 5.01 acres. It is an existing industrial premises located on the North side of Derwent Way (Grid Reference SE 42122 02009) on the Wath West Industrial Estate, which is located to the North-West of Wath-Upon-Deerne and North of Rotherham. The site falls within the administrative area of Rotherham Metropolitan Borough Council.
- 2.1.2 The site fronts directly onto Derwent Way on its Southern border. Bordering the permitted area to the North is a belt of green land which includes a public footpath, beyond this are industrial units off Manvers Way. There are industrial premises neighbouring the site on the Eastern boundary. To the West of the permitted area is an extension of hard standing land.
- 2.1.3 Access and egress for the site is situated directly from Derwent Way. There is also the option of accessing the site from Pontefract Road on the Western boundary.
- 2.1.4 The site currently comprises of staff and visitor parking, a platform weighbridge, a waste transfer station (WTS) building, HGV parking, container storage area, administration offices, and staff welfare facilities.

- 2.1.5 Having previously being used as a waste facility, the site benefits from internal surfaced roadways that provide access into the WTS building on its Northern façade.
- 2.1.6 The WTS building has a footprint of 782m<sup>2</sup> (or 8,417ft<sup>2</sup>) and is part concrete panels and part corrugated cladding. Access into the WTS building is via the Southern façade which is completely open. The floor of the WTS building is constructed from concrete.
- 2.1.7 There are x3 fire hydrants local to the facility on Dearne Lane and x2 on Derwent Way at neighbouring businesses. The directions of the fire hydrants are indicated within drawing DRC-FPP-009.

## 2.2 Sensitive Receptors

- 2.2.1 The nearest human receptors to a potential fire at the WTS building / material storage areas are likely to be workers on site. The sensitive receptors within 1km of the site have been considered, please refer to drawing DRC-FPP-001.
- 2.2.2 There are direct neighbouring businesses on the Eastern (Nu-Con) and Southern (Keyline Civils) boundaries of the permitted area. Beyond the green land to the North are various businesses on Dearne Lane.
- 2.2.3 The nearest residential receptors to the site are on Moorbridge Crescent to the West, Barnsley Road, and Grove to the South, all are in excess of 250m and 350m respectively (again from the centre of our site)
- 2.2.4 There is a nursery (Tiny Tots) which is 290m away from the site to the East, Brampton Ellis Primary School 880m away South-South-West, Brampton Cortonwood Infant School 740m away West-by-South and West Melton Primary School 960m away South-by-East.
- 2.2.5 There are no hospitals, nursing or care homes, bus stations or airports within 1km of the site boundary.
- 2.2.6 There are no Sites of Special Scientific Interest (SSSIs) within 250m of the site.

**Figure 2: DEFRA Magic Maps, SSSI survey**

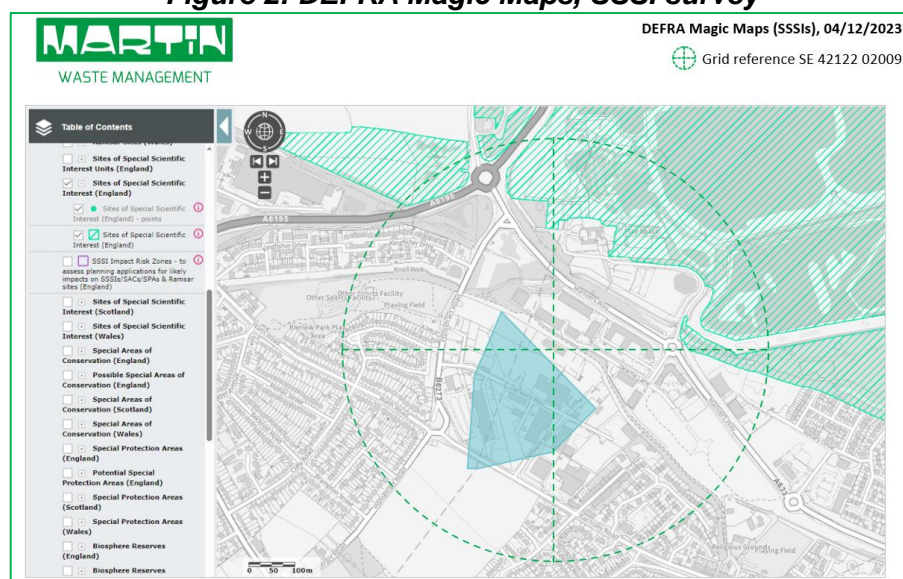

2.2.7 The nearest ecological designations are (i) Old Moor Wetland Centre which is 250m to the North-East of the site, (ii) the recreational area 250m West-North-West of the site and (iii) Knoll Beck River 355m to the East.

2.2.8 Table 1 below summarises the nearest sensitive receptors to the site.

**Table 1: Summary of Sensitive Receptors**

*NB: distances have been measured from the centre of the site.*

Boundary of transfer station	Land use	Distance / Direction
<b>Northern Boundary</b>	Century Businesses Park (various)	52m / N
	KC Sofas	50m / NE
	Big Wild Thought	85m / NE
	Technical Print	110m / NE
	Manvers Way (A633)	145 / NE
	Old Moor Wetland Centre RSPB Reserve	250m / NE
<b>Eastern Boundary</b>	Dearne Lane	105m / E
	Industrial units on Dearne Lane	165m / E
	Knoll Beck River	355m / E
<b>Southern Boundary</b>	Nu-Con	50m / S
	Derwent Way	130m / S
	Ultimate Accident Repair	145m / S
	Life Skills Rotherham	255m / S
<b>Western Boundary</b>	Keyline Civils	50m / W
	Industrial units off Derwent Way	195m / W
	Recreational area	250m / WNW
	Moorbridge Crescent	260m / W
<b>SSSIs</b>	Old Moor Wetland Centre RSPB Reserve	>500m / NE

### 2.3 Meteorological Conditions

2.3.1 The closest meteorological station to the site is Sheffield weather station, which is located circa 10.4 miles (16.7km) South-South-West from the site boundary. Due to its locality this weather station is considered the most suitable in terms of reflecting weather patterns likely to be experienced at the site.

2.3.2 Data from the windfinder.com website is based on measurements taken annually; the prevailing wind direction is indicated in Figure 2.1 below.

2.3.3 The wind rose below shows that the prevailing wind direction is predominantly from the West and the South-East. This indicates that the wind will be blowing principally towards the industrial premises to the east of the site boundary and towards the hardstanding on the North-West of the same property owned by HWMW.

**Figure 2.1: Sheffield Weather Station Wind Rose**

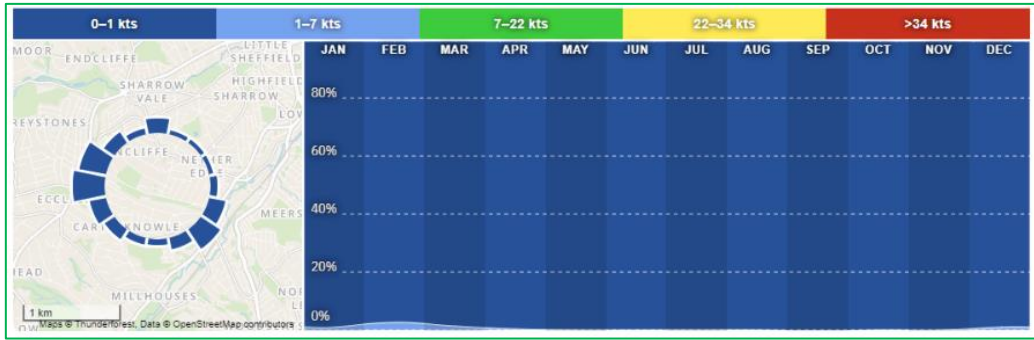

Source: Windfinder.com

2.3.4 The statistics below show the average temperature and rainfall relative to the site. With high average temperatures occurring in July and August and, lowest average rainfall occurring during April.

2.3.5 Hot and dry weather conditions will be considered when assessing the common causes of fire in section 5.

**Figure 2.2: Rotherham Weather Statistics**

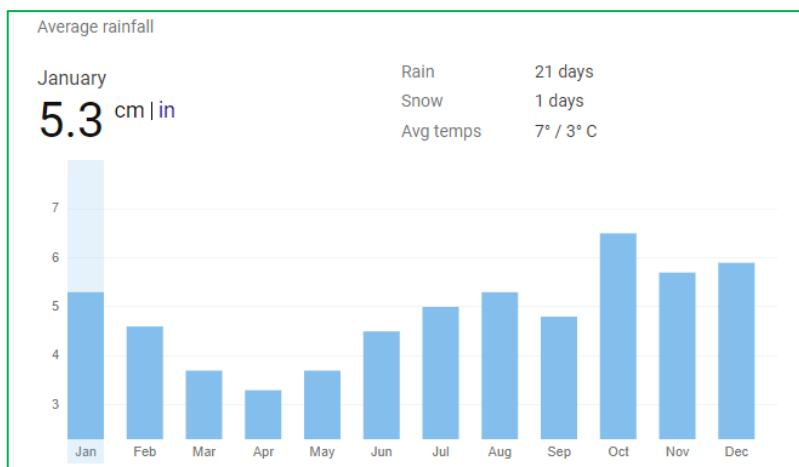
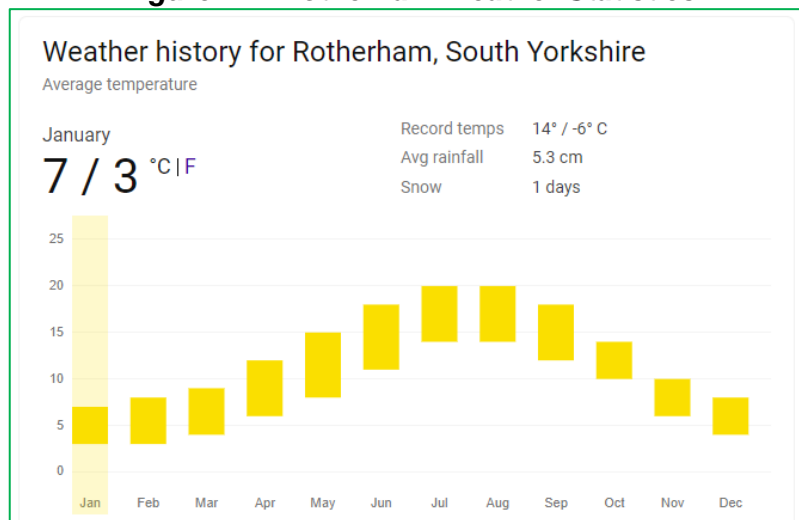

Source: Weather Trends

### 3. WASTE ACTIVITIES

- 3.1.1 The site is operating as a household, commercial and industrial waste transfer station and the total quantity of waste currently accepted onto the site will be less than 75,000 tonnes per year.
- 3.1.2 Segregated waste streams will be delivered into the site by RCV vehicles or articulated lorries with ejector trailers. As the site develops, HMMW plan to accept mixed Local Authority material as well as the segregated waste streams. In addition, there may also be some LA waste in small vehicles e.g. flatbed transits etc. from bulky collections.
- 3.1.3 HMMW accepts that there will be a minimal amount of contamination within the mixed dry recyclables and source segregated wastes delivered into this site.
- 3.1.4 Upon entering the site, all waste delivery / collection vehicles will be checked-in at the weighbridge, upon satisfactory documents and acceptance, the waste vehicles will then be directed towards the applicable storage area. Site staff direct the waste vehicle towards the designated waste bay / tipping area, giving instruction to deposit or collect the load when it is safe to do so. The waste vehicle returns to the weighbridge via the designated route. Routing for the site is shown in drawing DRC-FPP-003.
- 3.1.5 HMMW may have a baler installed at the site in the future, this will be compacting loose segregated waste materials for onward movement.
- 3.1.6 The source segregated materials are currently stored and then bulked for onward movement.
- 3.1.7 All materials are stored within individual bays for a maximum period of one month, before they are or sent out for onward treatment.
- 3.1.8 Table 2 below outlines the site activities, non-hazardous material storage, vehicle collection and delivery, maintenance, electrical and heating systems, office activities, and general site activities. The activity is listed alongside a brief description and the fire control measure in place, of which are discussed in further detail later in the plan.

**Table 2: Site Activities**

Activity	Description	Fire control measure
Weighbridge	Material received on and removed from site is weighed	Office equipment is PAT tested. Weighbridge is serviced annually. Fire extinguishers in place.
Delivery Vehicles	Vehicles enter site to tip off material in tipping hall	Serviced regularly. Vehicles carry fire extinguishers. Various fire extinguishers and Mist-Tech firefighting systems are available on site.
Material Tipping	Material is tipped into bays	Material stored within recommended pile sizes. Handheld thermal imaging camera used x2 per day to monitor stored material temperatures. CCTV is monitored off-site. Various fire extinguishers and Mist-Tech firefighting systems are available on site.
Material Storage	Source separated material. Mixed dry recyclables and general waste	Material is stored for a short period (not exceeding 1 month) and within the recommended stockpile sizes.



		Handheld thermal imaging camera used x2 per shift to monitor material temperatures. CCTV is monitored off-site. Various fire extinguishers and Mist-Tech firefighting systems are available on site.
Baled Material Storage	Processed baled material	Currently N/A.
Mobile Plant	Operation Park-up	Fitted with automatic engine fire extinguishers. Parked away from all combustible materials. Handheld thermal imaging camera used to investigate any potential heat source issues. CCTV is monitored off-site. Various fire extinguishers and Mist-Tech firefighting systems are available on site.
Hot Work Maintenance – welding etc.	Any maintenance required on the site equipment, including planned preventative maintenance	Permit to Work completed and fire watch in place. CCTV is monitored off-site. Various fire extinguishers and Mist-Tech firefighting systems are available on site. Handheld thermal imaging camera is available if required.
Maintenance – power tools	Any maintenance required on the site equipment, including planned preventative maintenance	Electrical equipment is PAT Tested and checked prior to use. CCTV is monitored off-site. Various fire extinguishers and Mist-Tech firefighting systems are available on site.
Jet Wash	Used for washing mobile plant	N/A.
Car Parking	Staff and Visitors Car Parking	Parking just inside the main entrance, separate from the main activities of the site and the main WTS building.
Office Equipment	Electrical Equipment – computers, etc.	All equipment is PAT tested. Fire extinguishers in place.
Diesel Tank & Oil Storage	Diesel and other oils are stored on site for the mobile plant	Diesel is stored externally in a bunded tank with 110% capacity, large oil drums are stored on bunds with 25% of largest drums capacity, away from combustible materials and drainage.
Smoking	Employees smoking on site	Designated smoking area away from all material storage and site activities. CCTV is monitored off-site. Various fire extinguishers and Mist-Tech firefighting systems are available on site.

### 3.2 Site Infrastructure and Security

3.2.1 Within the entrance of the site there is a platform weighbridge, adjacent to this is the administration office and welfare facilities to the right. To the left of the weighbridge is the workshop building with access into the workshop around the first right hand corner of this building. Also, in front of the workshop access point is an area used for parking HMMWs HGVs. Beyond the welfare facilities and on the right is staff and visitor parking and, beyond this is an area currently used for (RoRo) container storage. In between the container storage area and the HGV parking area is a ramp which allows access down to the lower level which includes material storage bays and the WTS building. Beyond the WTS building is a large area of hardstanding land used for storage which is enclosed by fencing and large gated access from Pontefract Road.

3.2.2 The WTS building and material storage bays will be built on impermeable concrete surfacing and these areas feed into a sealed drainage system.

- 3.2.3 The site is currently manned by operational staff between the hours of 08:00 and 17:00 Monday to Friday and occasionally to meet demand the site may operate out of these hours as well as, on Saturdays, Sundays, and Bank Holidays (this is to facilitate alternate working arrangements for HMMW and other third party clients)
- 3.2.4 The site perimeter is fully secured through the provision of 2.4m high security palisade fencing, chain link fencing or concrete walls around the perimeter and a large steel-framed security gate (3m in height) at the entrance of the site. Both the fencing and gates are inspected, faults reported, arrangements to conduct repairs will be made and details will be recorded.
- 3.2.5 The security gates and all doors are locked when the site is not in use. In the unlikely event of unauthorised persons scaling the perimeter fence, access to the administration offices, welfare facilities and the workshop building is prevented with all access doors being closed and / or locked when the facility is unmanned.
- 3.2.6 Unauthorised public access to the site will not be allowed.
- 3.2.7 A CCTV system operates on the site, which allows remote monitoring of various locations of the site from a central control room. The central control room will access any areas of concern or suspect activity when the site is unmanned. The appropriate action will then be taken which will include contacting key holders, and emergency services can be contacted if this is appropriate. Any faults with the CCTV system recorded and arrangements made to repair the faults as necessary.
- 3.2.8 Table 3 below lists the locations of the CCTV system cameras; the locations are also represented in drawing DRC-FPP-004.

**Table 3: Site CCTV**

Camera	Location	Capability
1	<b>Outside the entrance gate</b> External - to the right of the entrance gate as you face the entrance from Derwent Way.	Static, facing Derwent Way.
2	<b>Outside the entrance gate</b> External - to the right of the entrance gate as you face the site from Derwent Way.	Static, facing the external staff parking area and Derwent Way.
3	<b>Administration offices</b> External - on the first left hand corner of the administration offices.	Static, facing the door / entrance to the offices.
4	<b>Staff parking</b> External - fixed to a post just after the site welfare facilities.	Rotates, able to cover the staff parking area, the container storage area and the HGV parking area.  (option to use / rotate remotely)
5	<b>Weighbridge</b> External - fixed to the corner of the workshop building.	Static, facing the platform weighbridge.
6	<b>HGV parking</b> External - fixed to the corner of the workshop building.	Static, facing the HGV parking area and towards the WTS building.
7	<b>Workshop</b> Internal - fixed inside the roller shutter door.	Static, covering part of the workshop area.

<b>8</b>	<b>HGV parking / fuel store</b> External - fixed to the side of the workshop building.	Static, facing the HGV parking area, the full store and towards the staff parking area.
<b>9</b>	<b>HGV parking</b> External - fixed to a post adjacent to the ramp.	Rotates, able to cover the HGV parking area, the workshop roller shutter door and the lower level to the right of the WTS building.  (option to use / rotate remotely)
<b>10</b>	<b>External waste bays</b> External - fixed to a post adjacent to the ramp.	Static, facing the lower level right hand storage areas adjacent to the container storage area on the upper level.
<b>11</b>	<b>External waste bays</b> External - fixed to a post adjacent to the ramp.	Static, facing the lower level left hand storage areas to the right of the WTS building.
<b>12</b>	<b>WTS</b> External - fixed to a post across from the WTS building.	Static, facing the right hand side of the front of the WTS building.
<b>13</b>	<b>WTS</b> External - fixed to a post across from the WTS building.	Static, facing the left hand side of the front of the WTS building.
<b>14</b>	<b>HGV parking</b> External - fixed to the front right hand corner of the WTS building.	Rotates, able to cover the front of the WTS building, the quarantine bay and the area to the left of the WTS building.  (option to use / rotate remotely)
<b>15</b>	<b>WTS</b> Internal - fixed inside the right hand wall and in the centre of the WTS building.	Static, facing the inside left hand side of the WTS building.
<b>16</b>	<b>WTS</b> Internal - fixed inside the left hand wall and in the centre of the WTS building.	Static, facing the inside right hand side of the WTS building.
<b>17</b>	<b>Rear of the WTS</b> External - fixed to the rear right hand corner of the WTS building.	Static, facing the rear left hand side of the WTS building.

#### 4. WASTE ACCEPTANCE, STORAGE AND REJECTION

4.1.1 Only waste detailed in the environmental permit for the site will be accepted. These will be stored within bays or containers consisting of stable, mixed dry recyclables or inert materials as well as segregated waste streams e.g. card, wood and plastics. The table in Appendix 1 identifies the various waste types accepted at the site and the maximum material volumes to be stored in each bay / area.

4.1.2 The largest volume of waste material within the permitted area will be 384m<sup>3</sup> stored in bays 7, 8, 9 and 10. The quarantine bay will have a storage capacity of 256m<sup>3</sup>. Details of the waste storage for the site is shown in Appendix 1.

All storage bays will be constructed from concrete interlocking blocks and / or concrete panels. The bays inside the WTS and the external bays will have 1m freeboard which will aid in preventing the wind whipping of materials, reducing litter around the site and to ensure materials are contained on the impermeable surfaces of the site. Details of the blocks can be found in Appendix 8.

4.1.3 It should be considered that no loose waste material stockpiles can be stored in a full cuboid mound and that the open front of any loose material stockpile will be sloped at the open end / front of the bay. This would equate to a reduction in the maximum volume of waste material stored on site and would therefore

require a reduced volume of water to be supplied over a 3 hour period and, would also substantially reduce the volume of fire water that would need managed if an incident occurred. For this FPP we will continue to work on the basis that the largest stored volume of waste material will be 384m<sup>3</sup>.

- 4.1.4 Bay walls (separation and push-walls) will be made from concrete which is designated as grade A1 within the European Construction Products Directive EN 13501 – 1:2002, which is the highest classification of non-combustible material within the directive, with a minimum of 120 minutes of fire resistance. Further information can be found in Appendix 4.
- 4.1.5 Push-walls are checked monthly to ensure they are not damaged, that they are structurally sound and fit for purpose, i.e., will prevent the spread of fire between storage areas. Records of these checks will be retained on site and presented on request.
- 4.1.6 Waste materials will be held on site for either a day, a few days, or a week. Normally wastes on site shall not be stored for more than a month.
- 4.1.7 Loose processed materials will be held on site inside the WTS building or within the external bays until there is enough volume to make a lorry load which can be up to 101m<sup>3</sup>.
- 4.1.8 It is unlikely that the maximum volumes will be reached daily. However, seasonal variations will affect the volumes, at peak times such as Christmas and public holidays, there will be more material on site due to more volume arriving at site over a shorter space of time. To manage the seasonal variations of the types of waste received, HWMW's site staff will monitor and manage the haulage schedule and the use of off takers and aim to adjust the volume of material leaving site as required on an ad hoc basis.
- 4.1.9 The height of any open material bay separation walls takes in to account a 1 metre freeboard space that is not calculated within the material storage volume. The Material Bay Plan is shown in drawing DRC-FPP-005.
- 4.1.10 There will be no gas cylinders, aerosols, chemicals, or combustible liquids stored inside the WTS building or directly adjacent to any of the external waste storage bays.
- 4.1.11 The fuel store is fully bunded and will be located on the upper level adjacent to the workshop building roller shutter door, the location is shown in drawing DRC-FPP-009.
- 4.1.12 The risk of incompatible waste streams self-combusting has been minimised by these waste acceptance measures. Any materials on site not covered by the guidance (such as gas cylinders) have been considered in Table 2.
- 4.1.13 All staff are trained to be vigilant and identify any wastes that require segregation such as any gas bottles or drums with labels, i.e., flammable, corrosive and hazardous, etc.
- 4.1.14 Any gas cylinders found in material delivered into site will be removed from the WTS building or material storage areas and stored in a cage in away from waste material storage areas on the upper level and protected from site traffic.

- 4.1.15 Should any non-conforming items be identified staff are trained to follow the waste acceptance procedures and the Emergency Procedures contained within the site management system.
- 4.1.16 Staff are trained to be vigilant for any incoming hot loads although considered to be low risk due to the origin of the wastes accepted. If any are identified the Emergency Procedures will be actioned and the load will be isolated in the quarantine area / bay away from other waste materials stored on site.
- 4.1.17 Staff will use a handheld thermal imaging camera x2 during the day to monitor material temperatures and records of this monitoring will be retained on site. Details of the thermal imaging camera are in Appendix 2.

**Figure 4: Eclipse LDX Thermal Imaging Camera**



## **5. MANAGING THE COMMON CAUSES OF FIRE**

### **5.1 Arson or vandalism**

- 5.1.1 To prevent / reduce risk of arson all combustible loose waste is stored inside the WTS building or a covered and walled structure.
- 5.1.2 The site is covered by 24/7 monitored CCTV throughout.
- 5.1.3 The site currently has a total of x17 CCTV cameras, details are shown Table 3 and in drawing DRC-FPP-004.
- 5.1.1 The site perimeter is also secured with a combination of fencing and a large steel gate at the site entrance and the exit point of the site.
- 5.1.2 The integrity of the fencing and gates are inspected during a daily inspection of the site perimeter, a template of the Daily / Weekly Checksheet is shown in Appendix 3.

### **5.2 Plant & equipment**

- 5.2.1 HWMW will use telescopic handlers, forklift trucks, and possibly a 360° excavator (or similar) to handle wastes. All mobile plant moving loose, or baled waste will be fitted with fire extinguishers.
- 5.2.2 All mobile plant is defected using a traffic light system – if a red defect is noted the plant must be parked up and isolated until it is safe to use, see the site checks and maintenance sheet in Appendix 3. All mobile plant is checked before the start of each shift, using this defect system.

- 5.2.3 Scheduled maintenance and repair of any future leased forklift truck will be arranged and completed by:

Toyota Material Handling UK  
Northern Business Centre (Northern & Southern), 6 Kingsland  
Grange, Woolston, Warrington, WA1 4RW

- 5.2.4 Scheduled maintenance and repair of all other mobile plant will be arranged by the HWMWs sister company:

H W Martin Plant Limited  
Fordbridge Lane, Blackwell, Alfreton,  
Derbyshire, DE55 5JY

- 5.2.5 An example of mobile plant maintenance records can be seen in Appendix 3 (TH45, 07/02/2023) and all defects are actioned and closed out on the records. Records of all works undertaken on mobile plant by H W Martin Plant are stored at the above address.

- 5.2.6 All mobile plant will be parked up away from combustible materials when not in use. Park up locations are shown in drawing DRC-FPP-009.

- 5.2.7 As part of the HWMWs IMS (Integrated Management System) the National Plant Manager will have a comprehensive maintenance regime in place. All fixed plant is placed on a maintenance schedule which has daily, weekly, monthly, and annual checks.

- 5.2.8 All Plant defects are rectified as soon as practically possible, and any safety conscious issues are dealt with immediately and where necessary the plant is shut down until it is safe to use.

- 5.2.9 All site mobile and fixed plant is maintained with the manufacturer's recommendations and records of all servicing and repair are held by HWMW or with H W Martin Plant.

- 5.2.10 A handheld thermal imaging camera can also be used to identify any potential heat source issues.

### **5.3 Electrical faults including damaged or exposed electrical cables**

- 5.3.1 Fixed electrical wiring tests will be completed by an approved contractor as the site develops and a screen shot of the final report for the main building will be included as Appendix 7 once received and within a future revision of this document.

- 5.3.2 Underground electric cables supply site services and lighting only. All electrics on site will be fully certified by a qualified electrician and written procedures will be in place that set out regular maintenance requirements.

- 5.3.3 Equipment is monitored daily and full maintenance is carried out weekly, any damages would be found and rectified immediately, in the event that they were not, emergency procedures would limit the impact.

- 5.3.4 Electrical appliances are PAT tested every 5 years and a certificate is then issued, a screenshot of the report is included in Appendix 7.

- 5.3.5 There are no exposed low-level electrics which could be damaged or compromised by any fire waters within the WTS building or material storage areas.

#### 5.4 Discarded smoking materials

- 5.4.1 All contractors must have completed a generic and site specific induction within the last 12 months as a minimum. The inductions cover specifics such as the designated smoking area, site H&S signage, COSHH and what to do in the event of any emergency.
- 5.4.2 The site has an external smoking area which is located at the site entrance, on the upper level next to the workshop building and 70m away from any unprocessed combustible materials stored on site.
- 5.4.3 The designated smoking area has appropriate receptacles for the safe disposal of cigarette ends and E-cigarettes.

#### 5.5 Hot works

- 5.5.1 A Permit to Work system, for any hot works (such as welding and cutting) will be in place and an example of this is shown in Appendix 3.
- 5.5.2 The hot works includes the option to include a fire watch if required, which is set to check at 15, 30 and 60 minutes after any hot works are completed.
- 5.5.3 A handheld thermal imaging camera can also be used to identify any potential heat source issues.

#### 5.6 Industrial heaters

- 5.6.1 Not applicable, no industrial heaters will be used on site.

#### 5.7 Hot exhausts

- 5.7.1 Designated staff will monitor the site at regular intervals during the working day, to detect signs of fire from hot exhausts or engines. All mobile plant is cleaned down throughout the day and at the end of each shift to minimise the potential for an ignition source. When not in use, they are parked up away from all combustible materials.
- 5.7.2 No delivery / collection vehicles will be left unattended whilst in the material storage areas.
- 5.7.3 A handheld thermal imaging camera can also be used to identify any potential heat source issues.

#### 5.8 Ignition sources

- 5.8.1 There will be no specific sources of ignition such as naked flames, heating pipes, industrial space heaters, furnaces, gas supplies or incinerators on site during normal operations.
- 5.8.2 If an item of equipment is used on site that contains a source of ignition, it will be located at least 6m away from any combustible and flammable materials.

## 5.9 Batteries in ELVs

5.9.1 Not applicable, ELVs will not be accepted on site.

## 5.10 Leaks and spillages of oils and fuels

5.10.1 Site vehicles undergo regular maintenance and daily checks to ensure they are in good working condition to prevent fuel or lubricant leaks from site vehicles. See Appendix 3 for details of maintenance and daily check sheets.

5.10.2 Documented maintenance and inspection programme for mobile and fixed plant equipment will be implemented as detailed in Appendix 3.

5.10.3 On finding a spillage or leak it will be dealt with immediately with site staff using the appropriate containment media. The location of spill kits are shown in drawing DRC-FPP-009.

5.10.4 Any spills or leaks and the resulting remedial action will be reported to the Site Manager or Deputy, any spill kits or containment media used will be disposed of and the area thoroughly cleaned. Replacement spill kits or containment media will be ordered as appropriate.

## 5.11 Build-up of loose combustible waste, dust and fluff

5.11.1 Good housekeeping, cleaning and maintenance of mobile plant and fixed plant equipment will prevent the build-up of loose combustible waste, dust, and fluff. Visual daily site checks will be completed to monitor any dust, debris or waste accumulation on plant exhausts or hot surface and will be cleaned immediately.

5.11.2 Fire risk is also minimised by practising good housekeeping techniques and daily litter picking around the site to prevent the build-up of loose combustible waste. This will also be recorded within the Daily / Weekly Checksheet as shown in Appendix 3.

## 5.12 Reactions between wastes

5.12.1 None of the permitted wastes have the potential to be incompatible and create heat or fire from their admixture.

5.12.2 The site will operate according to the waste acceptance and material handling procedures detailed in the EMS. All staff are trained to be vigilant and identify non-conforming waste. The waste acceptance procedure will ensure that all wastes are inspected to identify any non-conforming, unstable, or incompatible wastes such as lithium batteries which can cause reactions between wastes. Any batteries found within waste streams (or as a result of site activities) will be stored separately depending on battery type and containment requirements such as lithium batteries layered within vermiculite granules.

5.12.3 The daily inspections completed on each shift will ensure that stockpiles and waste storage areas are inspected for any signs of smoking, smouldering or heat.

5.12.4 The use of the quarantine bay will ensure that any non-conforming wastes are segregated, a Fire Watch will be undertaken, and the thermal imaging camera used if required.



### 5.13 Deposited hot loads

- 5.13.1 As part of the IMS (Integrated Management System) for the site, HWMW will have in place daily checks completed visually by site staff. They are trained to watch for and identify any potential fires, i.e., smoke or embers, investigate further and if necessary, action emergency measures as defined in this FPP.
- 5.13.2 Fire drills will be undertaken to maintain effectiveness on a 6-monthly basis and records will be kept on site together with details of checks on the fire equipment.
- 5.13.3 To prevent incoming hot loads being deposited, staff are trained to be vigilant and identify any incompatible and non-conforming wastes including any hot loads (e.g., signs of smoke, smouldering or embers)
- 5.13.4 It is considered that a risk of a hot load is unlikely, in the event of a hot load being identified on site, it will be treated as a fire risk and directed to a safe area outside of the WTS building and away from other stored combustible or flammable materials and vehicles on site. Staff will only assist with active firefighting measures if it is safe to do so.
- 5.13.5 If on deposition, wastes are identified as a hot load, that waste will be segregated by mobile plant and taken to the quarantine area as defined in drawing DRC-FPP-005 and DRC-FPP-009. If required, the waste will be cooled and dampened by water using fire extinguishers and / or the Mist-Tech firefighting system. The hot load will be subject to a fire watch and the handheld thermal imaging camera used to monitor the temperature of the material. Further dampening will be undertaken if required.
- 5.13.6 The site has a Waste Acceptance Procedure in place, see Appendix 3, if a non-permitted, incompatible, or hot load was to be received on site the initial procedure would be to reject the load by contacting the customer and (where necessary) notifying the Environment Agency.
- 5.13.7 After the relevant parties have been informed and only when it is safe to do so will arrangements be made to dispose of the non-conforming waste to a suitable disposal facility.

### 5.14 Hot & dry weather

- 5.14.1 To minimise external heating of waste during hot and dry weather periods, waste materials received on site that are susceptible to ignition will be stored within the WTS building or under a covered and walled structure, meaning it is shaded from direct sunlight.
- 5.14.2 During hot and dry weather periods, the Senior Operations Manager or Site Manager / Foreman will decide whether the frequency of inspecting waste materials on site should be increased.
- 5.14.3 Loose waste materials which are not covered will be contained in metal roll-on roll-off containers, tip skips or material banks. Collection / removal of these full containers will be managed by site staff.
- 5.14.4 During sustained hot and dry weather periods, additional monitoring will be undertaken using the handheld thermal imaging camera and the frequency of

collections from the site can be increased if it deemed necessary by the Senior Operations Manager or Site Manager / Foreman.

## 6. PREVENTION OF SELF COMBUSTION

### 6.1 Management of storage times

To help prevent self-combustion maximum storage time of all materials on site will be as indicated within Table 4 below and shall not exceed a maximum of one month. These will be monitored and controlled by the Site Manager / Foreman and recorded on the check sheets as detailed in Appendix 3. The layout of the bays are shown in drawings DRC-FPP-005 and DRC-FPP-009.

**Table 4: Waste Storage**

Bay #	Material type	Form	Maximum storage duration on site	Process of rotation
2	Plastic bottles	Loose	1 week	Transferred to a second HWMW site or a third party off-taker for processing
3	Fibres (mixed paper and cardboard)	Loose	2 weeks	Transferred to a second HWMW site or a third party off-taker for processing
4	OCC (cardboard)	Loose	1 week	Transferred to a second HWMW site or a third party off-taker for processing
5	MDR (Mixed Dry Recyclate)	Loose	1 week	Transferred to a second HWMW site or a third party off-taker for processing
6	MDR (Mixed Dry Recyclate)	Loose	1 week	Transferred to a second HWMW site or a third party off-taker for processing
7	Wood	Loose	1 week	Transferred to a third party off-taker for processing
8	Hard plastic	Loose	1 week	Transferred to a third party off-taker for processing
9	Inert	Loose	2 weeks	Transferred to a third party off-taker for processing
10	Green waste	Loose	1 week	Transferred to a third party off-taker for processing
RoRos	Individual waste stream or mixed dry recyclate	Loose	1 week	Transferred to a second HWMW site or a third party off-taker for processing

6.1.1 The inclusion of a quarantine bay will aid with rotating bays and emptying loose material storage bays. Loose material bays will be swept clear when emptied and evidence will be retained on site.

6.1.2 The loose unprocessed material received on site will be transferred daily and so no loose material is likely to be more than a few days old however, we have

accounted for unplanned downtime and so have increased the maximum storage duration accordingly. Typically, all incoming wastes will be cleared within a few days, and this includes during peak periods.

- 6.1.3 There are also seasonal variations at Christmas and public holidays where a larger volume of material is received on site in a shorter period. Storage times may increase during these periods; however, any future processing can be increased, and outgoing material is booked out in advance to ensure there are enough loads dispatched from site to remove any back log.
- 6.1.4 The risk of incompatible waste streams self-combusting has been minimised by these waste acceptance measures. Any materials on site not covered by the guidance (such as gas cylinders) have been considered in table 2.
- 6.1.5 All staff are trained to be vigilant and identify any wastes that require segregation such as any gas bottles or drums with labels, i.e., flammable, corrosive, oxidising, and hazardous, etc.
- 6.1.6 Should any non-conforming items be identified staff are trained to follow the waste acceptance procedures and the Emergency Procedures contained within the site management system.
- 6.1.7 Staff are trained to be vigilant for any incoming hot loads although considered to be low risk due to the origin of the wastes accepted. If any are identified the Emergency Procedures will be actioned and the load will be isolated in the quarantine area.
- 6.1.8 Due to storage limitations on site many of these wastes are removed daily during busy periods but typically remain for no longer than 1 week. Paper, metal and plastics may be baled in the future ready for dispatch and stored within the WTS building or on the impermeable surface with sealed drainage. Loose segregated waste materials will be held on site inside the building until there is enough volume to make a lorry load which can be up to 101m<sup>3</sup>.
- 6.1.9 All wastes will be stored within purpose designed bays, as shown in drawing DRC-FPP-005.
- 6.1.10 All waste materials will be stored in their largest form.
- 6.1.11 The potential for fires due to external heating during hot weather is low due to a number of factors.
  - Combustible wastes are stored in individual metal RoRo containers or under cover within the WTS building or within a covered and walled structure preventing direct exposure from the sun.
  - Daily, the volume of waste in each bay is relatively small.
  - The majority of waste materials stored on site shall be stored in their largest form.

## 6.2 **Monitoring and control of temperature**

- 6.2.1 It should be considered that we do not meet the maximum pile sizes as defined in the Fire Prevention Plan guidance and no materials will be stored on site for more than 3 months. We will, however, undertake visual inspections and monitor the temperatures of waste x2 daily using the handheld thermal imaging

camera. Details of this thermal imaging camera system are shown in Appendix 2.

## **7. MANAGING WASTE IN BAYS**

- 7.1.1 All wastes will be stored within bays designed such that the maximum storage volume on the site in a single storage area is 384m<sup>3</sup>.
- 7.1.2 Separate bays and storage areas are shown in the site layout drawings depict the locations of loose segregated waste streams of mixed dry recycle.
- 7.1.3 Adjoining bays are separated by concrete fire walls that range in height up to a maximum height of 5m. The walls are sufficient to resist both radiative heat and flaming for at least 120 minutes to enable the fire to be extinguished within 4 hours. Appendix 4 shows the structural information for the fire walls. All bay walls are made from concrete which is designated as grade A1 within the European Construction Products Directive EN 13501 – 1:2002, which is the highest classification of non-combustible material within the directive. Also as discussed earlier the walls are checked monthly to ensure that they are fit for purpose to prevent fire from breaking through between bays.
- 7.1.4 In the event of a small fire in one of the loose waste storage bays, the telescopic handler or wheeled excavator with grab or bucket attachment can be used to isolate the affected materials into the quarantine bay provided it is safe to do so, as shown on drawings DRC-FPP-005 and DRC-FPP009.

## **8. PREVENTION OF FIRE SPREADING**

### **8.1 Waste Storage – Separation Distances**

- 8.1.1 Drawings DRC-FPP-005 and DRC-FPP-009 are plans showing the storage areas of materials and, Appendix 1 outlines the dimensions of the material volumes in each storage area. The storage areas are either separated by fire walls or a 6 metre separation distance. All storage areas are accessible from at least one side, with space in between the storage areas and site activities for ease of access – this enables the Fire & Rescue Service to access the areas with ease and assists with minimising the spread of fire between storage areas.
- 8.1.2 It is unlikely that (in most operating conditions) a fire would spread beyond a single bay and that the affected waste or adjacent bays could not be isolated.
- 8.1.3 In the event of a fire, trained mobile plant operatives have the option to remove (If it is safe to do so) any un-burnt material out of the way of the fire into the quarantine bay if necessary and to use the bucket if possible, to dampen out a small fire or to break up or remove any burnt material to help the fire be quenched. The removal of burnt material will take place under the instruction of the Fire & Rescue Service, as they will be able to advise when it is safe to move the material.
- 8.1.4 Training for site staff will include the following:
  - Abrasive wheels - if this is required at this site, the refresher / competence training will be completed every 3 years from the initial staff training.

- Fire / evacuation - drills will include a walkthrough of site staff closing surface water penstock valves. This will provide familiarisation for site staff and will ensure that the training remains relevant to them.
- Fire Marshall - refresher / competence training will be completed every 3 years from the initial staff training.
- First aid - refresher / competence training will be completed every 3 years from the initial staff training.
- LDX thermal imaging camera - equipment familiarisation and use will be provided by the equipment supplier (Angloco Ltd., Batley, West Yorkshire) In addition to this, site staff will be using this equipment daily which will ensure that its use remains relevant.
- Mist-Tech firefighting system - equipment familiarisation and use will be provided by the equipment supplier (Angloco Ltd., Batley, West Yorkshire) In addition to this the weekly testing of the system will be completed in rotation (dependant on availability) by the mobile plant operatives / site staff. This will provide coverage for absence and annual leave and will ensure that we have trained staff available on site at all times during operational hours.
- Mobile Plant Operatives - familiarisation on equipment, 20 hours supervised on equipment, an assessment of competence by a third party training provider. Refresher / competence training will be completed every 3 years after the initial award of competence.

*NB: the Senior Operations Manager will ensure that all key holders are familiar with the site, conversant in the use of the Mist-Tech system and the LDX thermal imaging camera, are able to correctly close the surface water penstock valves and are trained in the use of the mobile plant on site.*

## 9. QUARANTINE AREA

- 9.1.1 This area has been designed to be able to hold over 50% of the largest stockpile and is constructed with fire walls on three sides, with an open front. The fire walls limit the chance of material in the quarantine area either catching on fire (if it is un-burnt material) or the fire spreading (if it contains material that has been doused with water or is smouldering)
- 9.1.2 The quarantine bay is also within the operating range of the Mist-Tech system on the lower level when both hoses of this system are connected.
- 9.1.3 It is located on the lower level across from the front left hand corner of the WTS to allow easy access and egress for site staff and if required, the fire brigade for active firefighting to take place.
- 9.1.4 The location of the quarantine area is shown in drawings DRC-FPP-005 and DRC-FPP-009.

## 10. FIRE DETECTION

10.1.1 The site employs detection and firefighting techniques to minimise the risk of fire, including both design and operational measures.

10.1.2 A Fire Risk Assessment will be reviewed once the site develops and will form part of the Company's IMS and, will be reviewed by the Group SHEQ team as and when required (i.e., if there any changes to equipment or systems or materials)

10.1.3 Training of site staff will include the following:

- Operation of the surface water penstock valves.
- Fire and evacuation drills.
- Fire Marshal and first aid training.
- Using the thermal imaging camera and the Mist-Tech firefighting system.
- Operating mobile plant.

10.1.4 A Stratos Aspirating Smoke Detection system (also known as an aspiration or air sampling system) will be installed in the WTS building. This system works by continually sampling air through a network of sampling pipes into a laser detection chamber. The output of the chamber is processed by Artificial Intelligence which provide maximum sensitivity whilst minimising the risk of false alarms. This enables early warning capability in what can sometimes be a harsh environment (very cold, very hot or dusty) The details of this system can be seen in Appendix 5.

**Figure 10: Stratos Aspirating Smoke Detection system**

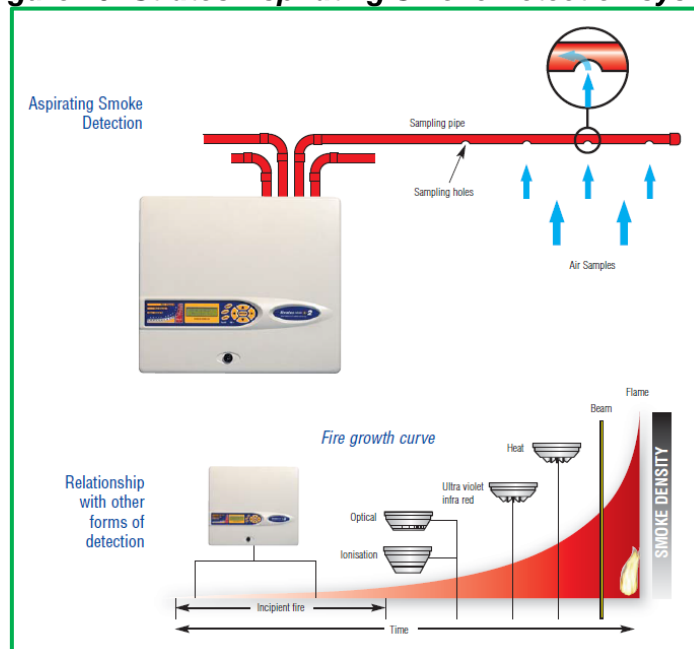

10.1.5 Detection for the site will include smoke detectors in the administration offices, the workshop and the welfare facilities which are linked to a fire alarm system.

10.1.6 Designated staff will monitor the site at regular intervals during the working day with visual inspections and by using the handheld thermal imaging camera, to

detect signs of fire or excessive heat sources. Details will be recorded, and these temperature monitoring records will be retained on site. The trigger levels and actions for the camera are detailed in Table 5 below.

**Table 5: Temperature Monitoring Trigger Levels**

Temperature Range	Action
Normal level = 30°C to 55°C	Temperatures are recorded.
Action level = >55°C and above	Management is informed. The area is isolated while an investigation takes place, including potential further monitoring. Site fire extinguishers and the Mist-Tech firefighting system will be readied.
High action level = 100°C and above	Material may be transferred to the quarantine area (if safe to do so), fire fought using onsite suppression, Fire and Rescue Service called and the Environment Agency notified.

10.1.7 All staff are trained to be vigilant and identify any incompatible non-conforming waste such as any gas bottles or drums with labels, i.e., flammable, corrosive, oxidising, and hazardous, etc. These materials have been considered in Table 2, with appropriate mitigation measures detailed.

10.1.8 There will be minimum of x5 manual alarm call points and x8 smoke detectors in the administration offices and welfare facilities which will trigger a fire alarm when activated.

10.1.9 The fire alarm and smoke detectors will be serviced annually to Clause 45 of BS5839 Code of Practice for Fire Alarm Systems and any scheduled maintenance is completed by an approved FIA Engineer from:

Empire Fire & Safety Ltd.  
Office13, The Randell Business Centre, Randall Park Way, Retford,  
Nottinghamshire,  
DN22 7WF

10.1.10 This fire alarm has audible alarms around the site and is also linked to a monitoring station off site which is manned 24/7 by:

Riber Surveillance Ltd.  
Unit 1, Thompson Street, Chesterfield,  
Derbyshire,  
S41 9AR

10.1.11 Upon activation of the fire alarm, Empire Fire & Safety would immediately contact the CCTV monitoring Company (Riber Surveillance) to investigate whether there is smoke or fire.

10.1.12 If there is smoke or fire visible on the CCTV, Riber would contact the Fire & Rescue Service to attend site immediately and they would also contact the HMMW key holder(s) to attend site.

10.1.13 If there is no smoke or fire visible on the CCTV, Riber would contact the HMMW key holder(s) to attend site to investigate. In this situation, Riber would continue to monitor the CCTV to see if anything escalates on site and would call the Fire & Rescue Service if necessary.

10.1.14 HWMW currently has x3 site key holders (The Senior Operations Manager, HWRC Contract Manager and the Plant Driver) Travelling time to the site for key holders ranges with the closest being 14 minutes away at normal road speed restrictions.

*NB: The number of key holders for the site will increase as the site becomes operational and when we employ more site staff.*

10.1.15 Duties of HWMW key holders will include the following:

- Attend the site as necessary out of operational hours to investigate activations.
- Liaise with emergency services and external parties such as the Environment Agency and the HSE.
- Movement of materials and / or site equipment.
- Closing the surface water penstock valves.
- Using the thermal imaging camera and / or the Mist-Tech firefighting system.
- Communication with HWMW staff.

10.1.16 All HWMW key holders will read through this document on a 6 monthly basis or when a new revision is issued.

## 11. FIRE SUPPRESSION

11.1.1 Fire extinguishers (foam, CO<sub>2</sub>, and powder) are provided throughout the site, in the administration offices, workshop and welfare facilities.

11.1.2 There will be x2 high capacity 50L portable fire extinguishers adjacent to storage areas in the WTS building and on the upper level. These wheeled extinguishers are mobile and easy to operate and are equipped with a highly flexible 5m hose and produce an 11m jet to extinguish burning material or to dampen down any suspect / smouldering material. Positions are shown in drawing DRC-FPP-009.

**Figure 11.1: 50L portable foam fire extinguisher**





- 11.1.3 Firefighting equipment is serviced annually by an FIA approved Engineer to BS5306 from Empire Fire & Safety Ltd.
- 11.1.4 Mist-Tech VMS 2000 misting firefighting systems are located within the permitted area and consists of;
- a firefighting centrifugal pump with x2 pressure outlets,
  - x2 manual hose reels complete with 60m hose on each reel,
  - x2 misting branches with interchangeable misting lances,
  - a 2,000L water tank which is fully piped into the mains water feed on site with a float system for autofill and shut-off and,
  - an integrated 150L tank which can be used for foam or wetting agents.
- 11.1.5 Each system provides over 35 minutes of active firefighting in mist mode or over 20 minutes of active firefighting if in jet mode. This is based upon our Mist-Tech systems having an A406 branch, 2,150 litres of water and foam and having 25 bar of water pressure (57L/min for mist or 90L/min for jet)
- 11.1.6 The location of the Mist-Tech systems are shown on drawing DRC-FPP-009.
- 11.1.7 The benefits of having this system in place is that it extinguishes fires rapidly, provides superior cooling, saves water, it is safe on electrical fires, it is less of a flooding risk, there is no thermal shock, and it is safe for users due to the mist barrier between fire / heat and the operator.
- 11.1.8 The positioning of this system with the 60m hoses enables active firefighting at all points of the site where materials are tipped and stored. Details of this system are shown in Appendix 6.
- 11.1.9 Having the misting lances in place enables active firefighting within the pile of waste material and not just at the surface.

**Figure 11.2: Angloco Mist-Tech firefighting system**

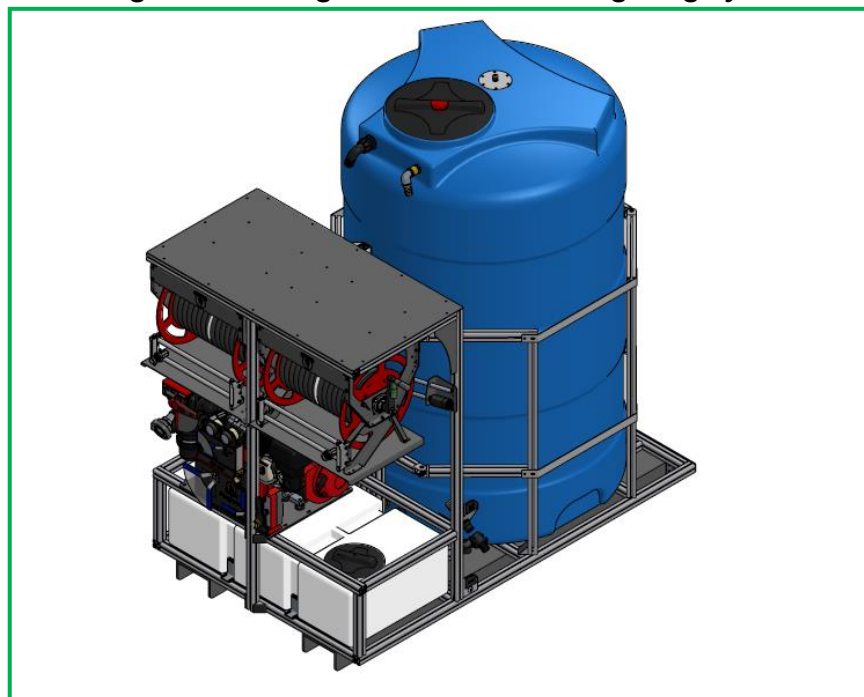

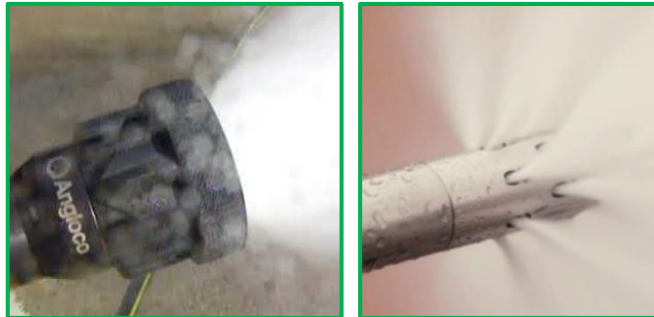

## 12. FIREFIGHTING TECHNIQUES

- 12.1.1 The fire detection and warning plan is outlined as part of the site Fire Risk Assessment.
- 12.1.2 A certified fire warden will be on site duty during operational hours.
- 12.1.3 In the event of a fire or smoke being detected, site staff are trained to follow the site Emergency Procedures contained in the Management Plan. Any incident will also be recorded on the company database.
- 12.1.4 On activation of the fire alarm or on the detection of smoke or fire, staff would raise the alarm via the two way radios, evacuate the area and stop any third party contractors or visitors from entering the site. Depending on the severity of the issue a decision would be made as to whether site staff could deal with the incident or whether the Fire & Rescue Service would need to be called.
- 12.1.5 Equipment such as fire extinguishers, protective clothing and pollution control equipment will be stored throughout the site.
- 12.1.6 Site staff will be trained to extinguish small fires with the appropriate fire extinguishers and the Mist-Tech firefighting system.
- 12.1.7 In addition, mobile plant operatives will use the mobile plant to remove any un-burnt material out of the way of the fire and into the quarantine bay if necessary and, will use the bucket (if possible and safe to do so at the time), to dampen out a small fire or to break up or remove any burnt material to help the fire be quenched. The removal of burnt material will take place under the instruction of the Fire & Rescue Service, as they will be able to advise when it is safe to move the material.
- 12.1.8 The details of the fire stations local to the site (In the district of Rotherham) are shown in drawing DRC-FPP-007.
- 12.1.9 The nearest station is in Dearne Community Fire Station which is 2.2 miles (6 minutes travel time at normal speed limits) away from the site. We have been in contact with a Station Master from South Yorkshire Fire & Rescue, and they have confirmed that:

- (i) crews would more than likely be deployed from this station,
- (ii) they would initially deploy x1 appliance with a crew to attend if, an incident was not in a building,
- (iii) they would deploy x3 appliances (x2 from Dearne and x1 from the Cudworth station in Barnsley) if an incident was inside a building,
- (iv) they estimate arriving within around 3 minutes at the site from the initial call out and,
- (v) support appliances would attend from the surrounding areas if the situation arose and dependant on the available resource at the time.

12.1.10 The second closest fire station local to the site (Rotherham) is also shown in drawing DRC-FPP-007, this is 7 miles from the site (20 minutes travel time at normal speed limits)

12.1.11 Once the Fire & Rescue Service are on site the Site Manager / Foreman or deputy will take instruction from them and if they require assistance with moving material or equipment. Staff trained in operating mobile plant will also be on hand to assist if required. The Fire & Rescue Service will have access to the water hydrants external to the site and will be able to pump water through and into the site.

12.1.12 A Fire Safety Document folder is kept within a Fire Safety Documents box which is located at the main entrance to the site off Derwent Way. A copy of this folder will also be kept by key site staff in the unlikely event that the box is not accessible. The information within this folder will be emergency contacts for the site, the fire prevention plan drawing, material storage areas, the site drainage plan as well as a plan showing the location of sensitive receptors local to the site.

12.1.13 Emergency services access to the site will be through the main entrance gate off Derwent Way or the alternate gated entrance to the site off Pontefract Road.

12.1.14 The Fire & Rescue Service would take control of the situation and they have the option to utilise HMMW staff and mobile plant to help control the situation.

12.1.15 Other considerations that would need to be taken into consideration are wind direction, smoke, weather conditions, etc. The potential impact of smoke on nearby receptors and the surrounding industrial area, would need to be monitored and the emergency services notified as necessary.

12.1.16 There are x3 fire hydrants local to the facility, these are found on (i) Century Business Centre on Dearne Lane (Grid reference SE 42330 01934), 100m from the rear of the site, (ii) at the front of Ultimate Accident Repair on Dearne Way (Grid reference SE 42047 01825), 110m from the front of the site and, (iii) at the entrance to Keyline Civils on Derwent Way (Grid ref: SE 42038 01929), 117m away from the front of the site. All x3 hydrants have a pipe diameter of 150mm.

12.1.17 Once the fire has been extinguished any solid and liquid wastes will be disposed of at a suitably licenced facility, once the Fire & Rescue Service have deemed it safe to do so.

12.1.18 As a minimum, HMMW will carry out Emergency Fire and Spill drills on a 6 monthly basis to maintain their effectiveness.

12.1.19 Emergency lighting will be provided within the site buildings which are checked internally every month and are serviced annually in accordance with BS5266 Code of Practice for Emergency Lighting by Empire Fire & Safety.

### 13. WATER SUPPLIES

13.1.1 With regards to water supply requirements, the Environment Agency’s Fire Prevention Plan Guidance considers a worst-case scenario would be “your largest waste pile catching fire” and quotes an example of a water supply of at least 2,000 litres a minute for a minimum of 3 hours for a 300 cubic metre pile of combustible material.

13.1.2 The largest individual waste storage currently on the site will hold as maximum volume of 384m<sup>3</sup>. This equates to a requirement of 2,560 litres per minute or 46,080 litres for 3 hours (A volume of 460.80m<sup>3</sup> of water)

13.1.3 A suitable fire hydrant is identified as being 100m from its connection point to the rear of the permitted area.

13.1.4 Water would be drawn direct from the fire tenders and backed up where necessary from the closest fire hydrant at the rear of the site or the x2 alternate hydrants local to the front of the site. Due to the position of the site and the topography of the industrial estate, we believe that the fire hydrants local to the site would have a minimum pressure 3 bar.

*NB: this would be dependent on the demand at the time on the industrial estate.*

13.1.5 Fire hydrants with 150mm diameter would supply:

- >4,850 litres of water per minute at a distance of 100m.
- >4,640 L/p/min @ 110m.
- >4,500 L/p/min @ 117m.

**Figure 13: Copely Developments flow rate calculator**

	Quantity Fluid Flow vs Hose Length Data				
Length	20.000	40.000	60.000	80.000	100.000
Quantity Fluid Flow (litres per minute)	9517.776	7274.386	6113.461	5374.874	4852.221
Bore Diameter (mm)	150	150	150	150	150
Pressure (bar)	3	3	3	3	3
Bore Diameter (ins)	5.906	5.906	5.906	5.906	5.906

Quantity Fluid Flow vs Hose Length Data					
Length	22.000	44.000	66.000	88.000	110.000
Quantity Fluid Flow (litres per minute)	9196.069	6989.528	5860.707	5146.279	4642.238
Bore Diameter (mm)	150	150	150	150	150
Pressure (bar)	3	3	3	3	3
Bore Diameter (ins)	5.906	5.906	5.906	5.906	5.906

Quantity Fluid Flow vs Hose Length Data					
Length	23.400	46.800	70.200	93.600	117.000
Quantity Fluid Flow (litres per minute)	8989.348	6808.936	5701.344	5002.576	4510.484
Bore Diameter (mm)	150	150	150	150	150
Pressure (bar)	3	3	3	3	3
Bore Diameter (ins)	5.906	5.906	5.906	5.906	5.906

- 13.1.6 The Fire & Rescue Service will have the option to call up the water provider and increase pressure to the water main supplying the hydrant in the event of a fire, if more water is required.
- 13.1.7 The direction / location of the fire hydrants are shown on drawing DRC-FPP-009.
- 13.1.8 In addition to the available water from the fire hydrants local to the site, we will have x2 15,000 litre tanks at the rear left hand corner of the WTS which will contain rainwater harvested from the WTS building roof.
- 13.1.9 The volume of harvested rainwater within these tanks will fluctuate depending on the time of year and how much is used on site for cleaning mobile plant and for dust suppression around the site.
- 13.1.10 The position of the rainwater storage tanks is shown in drawing DRC-FPP-009.

## 14. MANAGING FIRE WATER

- 14.1.1 The site drainage system is shown in drawing DRC-FPP-002.
- 14.1.2 If the largest volume of waste currently is 384m<sup>3</sup> and if this was to set on fire, approximately 460,800 litres (460.8m<sup>3</sup>) of water would be needed to extinguish the fire over a 3-hour period. We would expect the resulting fire water volume to be less than 460.8m<sup>3</sup> due to the process of evaporation and the potential absorption from the burning material.
- 14.1.3 Yorkshire Water who manage the drainage / sewer systems in the area will be contacted to ask for their permission to discharge firewater into the foul sewer if an incident occurs. The overriding principle will be to contain firewater on site so that we can arrange to have it analysed before having it vacuumed into tankers and taken to an approved facility for treatment / disposal.
- 14.1.4 The containment of firewater on the site will be provided with a combination of the following zoned containment areas:
- A. The external / upper level container area = 202m<sup>3</sup>.

- B. The external / upper level workshop, administration offices / welfare facilities and parking area = 428m<sup>3</sup>.
- C. The external / lower level adjacent to the WTS building = 1002m<sup>3</sup>.

**Figure 14: Example penstock valve which will be installed in the surface drainage system**



14.1.5 The total combined firewater containment for the site is shown in the below table and in drawing DRC-FPP-008.

**Table 6: Fire Water Containment**

Area	Capacity
A - Container storage area (Upper level)	<b>202 m<sup>3</sup></b>
B - Workshop, administration offices / welfare facilities and parking areas (Upper level)	<b>428 m<sup>3</sup></b>
C - Area adjacent to WTS building (Lower level)	<b>1,002 m<sup>3</sup></b>
<b>Total Fire water containment</b>	<b>1,632 m<sup>3</sup></b>

14.1.6 Site surface drains and the interceptor on site will be cleaned by an external contractor (such as Lanes for Drains or Harpers Environmental) every 6 months or as and when required to ensure that they are maintained and in good working order.

14.1.7 The site does not border any groundwater Source Protection Zones and there are no private drinking water abstractions within 100m of the site. Any risk of pollution from fire water from our site is mitigated due to, all our wastes being stored on impermeable surface with sealed drainage.

14.1.8 The site is not located within a Groundwater Vulnerability area, any risk would be mitigated due to the fire water containment area being an impermeable surface area with sealed drainage.

**Figure: 14.1: DEFRA Magic Maps, SPZ Survey**

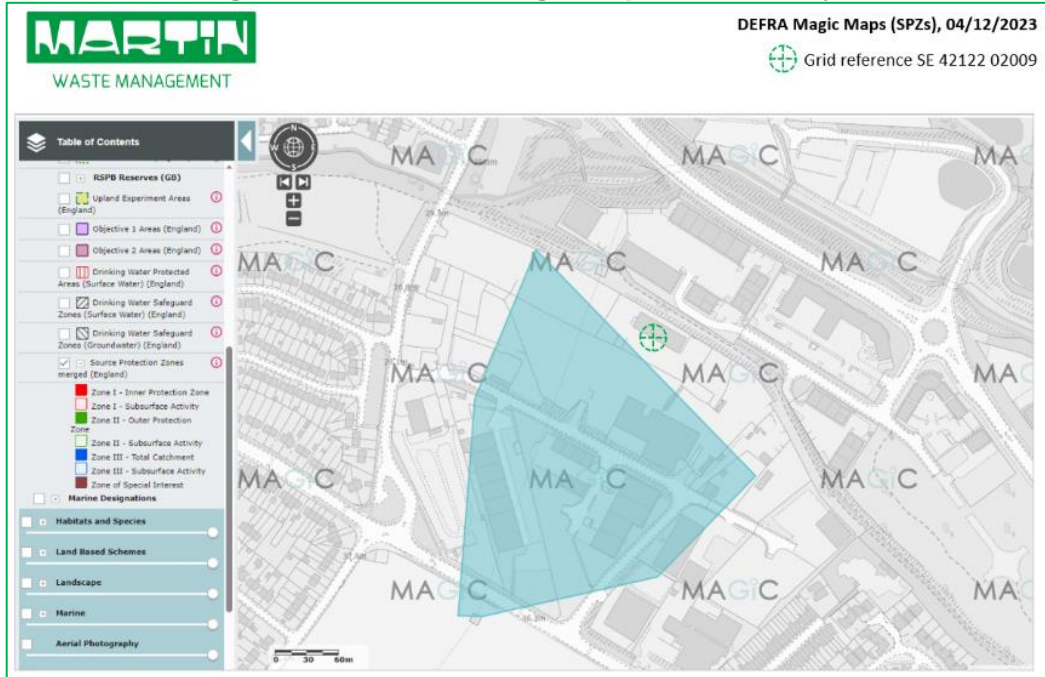

**Figure 14.2: DEFRA Magic Maps, Groundwater Vulnerability Survey**

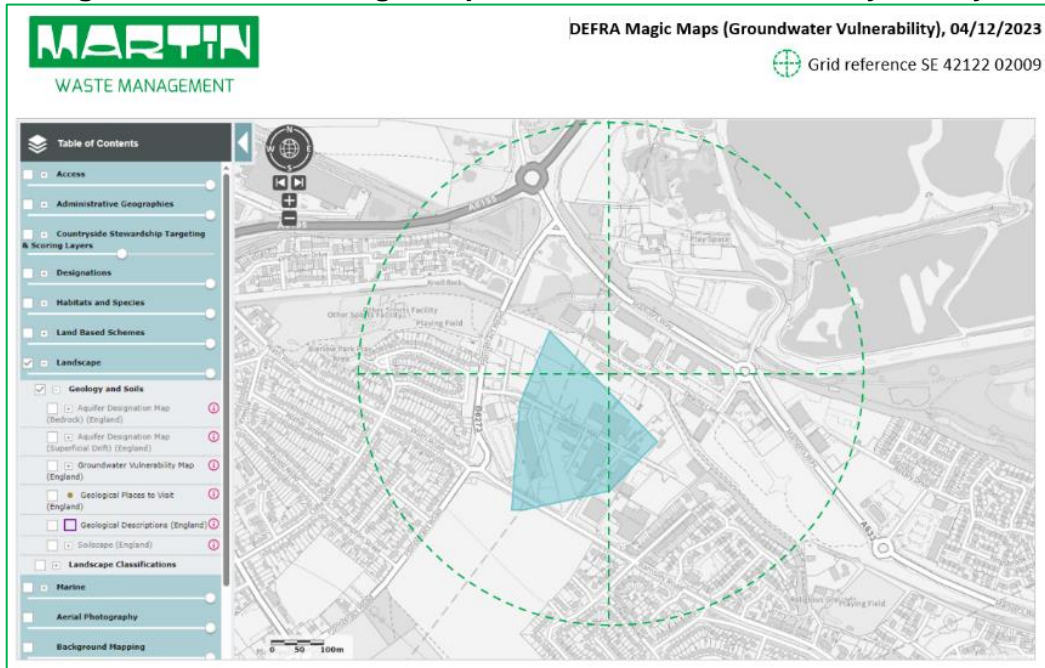

## 15. INCIDENT MANAGEMENT

15.1.1 The Site Manager / Foreman will liaise with the Emergency Services, Environment Agency and all other receptors throughout the incident, senior management and the Companies Compliance Manager and Health & Safety Advisor will also be available to provide guidance both during and after the incident.

- 15.1.2 On site there is a 'Fire Safety Documents' box that contains site specific information. These documents can be accessed by the emergency services and HWMW staff. Copies of this site specific information will also be held by key site staff.
- 15.1.3 The Fire Risk Assessment will be included as part of the site management system. Actions in the event of an emergency are included depending on the severity of the fire.
- 15.1.4 Upon the detection of any fire the site will be closed to all (non-essential) vehicles and persons. A member of staff will be positioned at the entrance of the site to direct emergency vehicles and to redirect delivery vehicles to the nearest alternative facility.
- 15.1.5 The fire assembly point for the site is outside the main gated entrance to the right and a good distance from the permitted waste operation / activities, this is shown on drawing DRC-FPP-009.
- 15.1.6 A long burning / smouldering fire is likely to have a greater impact on people, neighbours, infrastructure, and the environment including the surrounding industrial estate.
- 15.1.7 Other considerations which would need to be taken into consideration are wind direction, smoke, weather conditions, etc. and the potential impact of smoke on the nearby sensitive receptors. The wider road network should be monitored, and the emergency services notified as necessary.
- 15.1.8 All neighbouring businesses will be contacted on the initial discovery of the fire and will be updated throughout the incident.
- 15.1.9 Once the site is deemed safe by the Fire & Rescue Service, the clean-up process can commence.

## 15.2 **Post-Fire Clean-Up**

- 15.2.1 In the event of a fire a range of measures will be undertaken before the site can be fully operational again. HWMW will inform the Environment Agency of progress with these measures. All 'Duty of Care' obligations will be complied with at all stages of the clean-up. The site will not become operational again until approval is sought from the Environment Agency.
- 15.2.2 Firewater will be pumped into tankers for off-site disposal to a suitable permitted facility. Alternatively, there is the option to contact the local water authority and apply for a Short Term Discharge Authorisation to allow the firewater to be disposed of via the trade sewerage system on the industrial estate.
- 15.2.3 Used absorbents and flood containment media will be analysed by a third party contractor and disposed of at an appropriate site. All absorbents and flood containment media will be replenished and replaced.
- 15.2.4 Solid wastes will be sent off-site for disposal at a suitable permitted facility.



15.2.5 Any fire damaged waste will be characterised to enable determination of a suitable facility for recovery or disposal of the affected waste, which may include the following:

- Waste characterisation by visual sorting.
- Compositional analysis of the waste material.
- Waste acceptance criteria testing for landfill.

15.2.6 A structural engineer will carry out a structural survey to determine if the building has received any damage. From the structural reports or findings HWMWs senior management team will determine whether the site is safe to re-open, either with no damage occurring or with minor repairs that can take place whilst the site is operational. If major repairs are needed an assessment will be made into the length of time this will take and the continuing of the use of alternative outlets in the short or long term.

15.2.7 If the fire was limited to only part of the site, operations at the site will be restricted to the unaffected area, providing that (i) it is safe to do so and (ii) that the site can comply in full with the permit conditions. No site operations will commence in the affected area until all inspections and necessary repairs have been carried out and advice is given by the Environment Agency.

15.2.8 The Environment Agency will be notified of the inspections and repairs undertaken within 5 working days and recommencement of full site operations.

## 16. REVIEW OF THE FIRE PREVENTION PLAN

16.1.1 Following any significant fire event at the site an investigation of the incident will be undertaken and procedures and plans will be reviewed.

16.1.2 Taking into consideration findings of the investigation, these procedures and plans may be amended to improve fire preventative measures and fire response measures in the future.

16.1.3 All modifications to this Fire Prevention Plan will be controlled and require the plan to be identified with a revision number.

### Change History / Document Review

Revision No.	Effective Date	Significant Changes	Previous Revision No.
0.1	16/02/24	Initial issue / revision to EA.	-
0.2	19/06/24	Updated content of section 14 on receipt of revised firewater drawing, included drawing DRC-FPP-08	0.1
0.3	12/08/24	Minor grammatical changes, references to "during site development" and canopy details removed, various updated site plans included, upgraded CCTV detail included, table 4 (wastes) and appendix 1 updated, detail regarding required fire water and fire water retention updated in light of increased storage volumes, aspiration system detail and staff training elements included.	0.2
0.4	14/08/24	Amended site plans to reflect revised / proposed permit boundary.	0.3
0.5	12/03/25	Amended Material Bay Plan and Fire Prevention Plan drawings included.	0.4
0.6	18/03/25	Amended Material Bay Plan and Fire Prevention Plan drawings included.	0.5

## 17. FIRE PREVENTION PLAN SUMMARY

17.1.1 With reference to the guidance and following 3 objectives:

1. minimise the likelihood of a fire happening;
2. aim for a fire to be extinguished within 4 hours; and
3. minimise the spread of fire within the site and to neighbouring sites.

We believe we meet the objectives within the guidance with the following measures:

### **Minimise the likelihood of a fire happening**

- The site is manned during operational hours and is also covered 24/7 by monitored CCTV meaning that the risk of arson or vandalism is minimal.
- All fixed and mobile plant is maintained and routinely inspected.
- All mobile plant used on site will be parked away from combustible materials when not in use.
- There is only x1 designated smoking area which is independent to the main waste operation and away from all combustible materials.
- Electrical works on site are only undertaken by qualified contractors covered by the Permit to Work system.
- All hot works are only undertaken when covered by the Permit to Work system with fire-watch checks in place.
- All pile sizes are minimised in line with the guidance, all mixed materials are processed quickly or are removed from site in a timely fashion and all loose material bays should be emptied (as a minimum) every 3 months.
- We have included a quarantine bay which can be used for any hot loads or smouldering material found.
- Thermal monitoring will identify any hot material which can then be managed by again using the quarantine bay.
- We have fire equipment on site to use for hot or smouldering material to prevent a fire from occurring.

### **Aim for a fire to be extinguished within 4 hours**

- As the site is manned during operational hours, is externally monitored via the CCTV system and as we will be undertaking thermal monitoring, we believe that if a fire was to occur, it would be caught in its early infancy.
- We are able to undertake active firefighting (when it is safe to do so) by using the fire extinguishers, high capacity fire extinguishers and the Mist-Tech situated on site.
- Using concrete walls provides radiative heat and flaming resistance for at least 120 minutes, this will enable a fire to be extinguished within 4 hours.
- Transferring burning material or waste away from burning material into the quarantine bay will assist in extinguishing a fire promptly.
- Due to the proximity of the Fire & Rescue Service they will be able to attend site quickly which will assist greatly in having fire extinguished within 4 hours (South Yorkshire Fire & Rescue Service estimated that pumps would arrive on site within 3 minutes of the initial call out)

- We have fire hydrants situated local to the site which will provide sufficient water supply for the Fire & Rescue Service.

**Minimise the spread of fire within the site and to neighbouring sites**

- Using concrete walls provides radiative heat and flaming resistance for at least 120 minutes, this will enable a fire to be extinguished within 4 hours.
- All pile sizes are minimised in line with the guidance meaning that incidents can be isolated if they occur.
- A 'freeboard' will be kept at the top of any adjoined material storage bay separating walls to prevent the spread of fire.
- We are able to undertake thermal monitoring during an incident to identify hot spots in surrounding materials.
- We are able to use our quarantine bay to move burning material or waste into to assist with isolating an incident.
- It is highly unlikely that a fire would spread to the closest neighbouring building as it has in excess of 6 metres separation distance from our material storage points.

# DRAWINGS

## DRAWING DRC-FPP-001

### QUADRANT A

#	Receptor	Dist. M	Direction from site	Grid Reference
1	Century Business Park	52	North	SE 42115 02080
2	Manvers Way (A633)	165	North	SE 42125 02171
3	Old Moor Wetland Centre RSPB Reserve	200	North	SE 42129 02231
4	Dearne Valley Parkway (B6273)	555	North	SE 42113 02538
5	Recreational area	465	North-by-West	SE 41987 02456
6	Highgate	475	North-by-West	SE 41950 02450
7	Highgate, residential	605	North-by-West	SE 41931 02583
8	The Sidings, residential	700	North-by-West	SE 41910 02638
9	Old Moor Tavern	935	North-by-West	SE 41941 02930
10	Everill Gate Lane	960	North-by-West	SE 41929 02942
11	Leon Grant Clothing	940	North-by-West	SE 41836 02877
12	Everill Gate Lane, residential	850	North-by-West	SE 41770 02775
13	Willow Farm	805	North-West	SE 41590 02617
14	Cranswick Convenience Foods	990	West-North-West	SE 41243 02479
15	Flexseal Portal	900	West-North-West	SE 41290 02421
-	D L G Auto Services	900	West-North-West	SE 41290 02421
16	Premier Inn Barnsley (Dearne Valley)	775	West-North-West	SE 41403 02311
-	The Meadows, Brewers Fayre	775	West-North-West	SE 41403 02311
17	Valley Park Estate	690	West-North-West	SE 41605 02333
18	Dearne Valley Parkway (B6273)	490	North-West	SE 41784 02310
19	Kingfisher Drive, residential	300	North-West	SE 41898 02228
20	Pontefract Road	240	North-West	SE 41945 02197
21	Recreational area	250	West-North-West	SE 41887 02106
22	Industrial units off Derwent Way	195	West	SE 41925 02014
23	Moorbridge Crescent, residential	260	West	SE 41852 02009
24	Wath Road, residential	290	West	SE 41610 02021
25	Wath Road	580	West	SE 41530 02014
26	Chapel Avenue, residential	660	West	SE 41465 02027

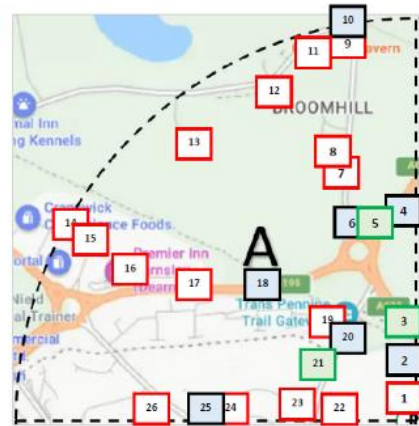

DRC-FPP-001

Derwent Recycling Centre, Sensitive Receptors Plan

04/12/2023

### QUADRANT B

#	Receptor	Dist. M	Direction from site	Grid Reference
1	Dearne Lane	105	East	SE 42227 02006
2	Industrial units, Dearne Lane	165	East	SE 42284 02008
3	Manvers Way / Old Moor Ln, roundabout	255	East	SE 42371 02008
4	Knoll Beck, river	355	East	SE 42473 02010
5	K C Sofas	50	North-East	SE 42166 02050
-	Big Wild Thought	85	North-East	SE 42210 02061
-	Technical Print	110	North-East	SE 42197 02087
6	Manvers Way	145	North-East	SE 42222 02114
7	Old Moor Wetland Centre RSPB Reserve	190	North-East	SE 42249 02154
8	Old Moor Wetland Centre	245	North-North-East	SE 42190 02247
9	Dearne Valley Parkway (B6273)	600	North	SE 42125 02592
10	Recreational area	755	North	SE 42120 02773
11	Waterfront Golf Club	780	East	SE 42891 01997

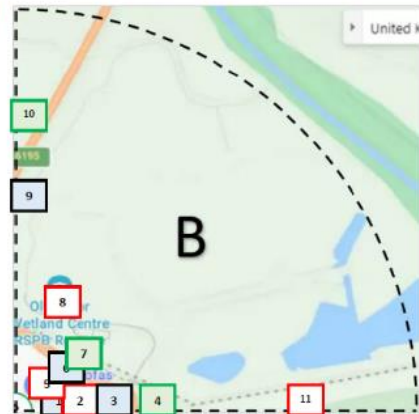

DRC-FPP-001

Derwent Recycling Centre, Sensitive Receptors Plan

04/12/2023

**QUADRANT C**

#	Receptor	Dist. M	Direction from site	Grid Reference
1	Keyline Civils	50	South	SE 42135 01913
2	Derwent Way	130	South	SE 42133 01877
3	Ultimate Accident Repair	145	South	SE 42124 01866
4	Life Skills Rotherham	255	South	SE 42102 01756
5	Barnsley Road	335	South	SE 42121 01686
6	Barnsley Road, residential	360	South	SE 42122 01669
7	Grove Road, residential	360	South	SE 42122 01669
7	Grove Road	420	South	SE 42099 01582
8	Elliot Close & Browning Road	590	South	SE 42140 01423
9	Coleridge Road	675	South	SE 42108 01334
10	Recreation area	765	South	SE 42009 01273
11	Christchurch Road	850	South	SE 42114 01156
12	Ellis Grove, residential	729	South-South-West	SE 42834 01335
13	Brampton Road	985	South-by-West	SE 41990 01042
14	Brampton Ellis CoFe Primary School	880	South-South-West	SE 41773 01207
15	Brampton Road, residential	825	South-West	SE 41606 01366
16	Dearne Valley Pet Centre	785	South-West	SE 41575 01446
17	Brampton MOT Centre	785	South-West	SE 41575 01446
17	Pontefract Road, residential	375	South-West	SE 41831 01830
18	Pontefract Road	290	South-West	SE 41881 01872
19	Norham Plastics	215	West-by-South	SE 41929 01924
20	Semlo Fabrications	215	West-by-South	SE 41929 01924
20	Industrial units off Derwent Way	195	West	SE 41925 02014
21	Moorbridge Crescent, residential	260	West	SE 41852 02009
22	Wath Road	585	West	SE 41503 02033
23	Dearne Road / Chapel Avenue	675	West	SE 41442 02042
24	Knollbeck Lane	870	West	SE 41243 01919
25	Brampton Post Office	870	West	SE 41243 01919
25	Brampton Cortonwood Infant School	740	West-by-South	SE 41395 01866
26	Recreation ground	655	West-South-West	SE 41563 01689
27	Paw 4 A Day School	785	South-West	SE 41527 01514
27	Squad Fitness	785	South-West	SE 41527 01514
27	The Bulls Head	785	South-West	SE 41527 01514
28	Westfield Road	830	South-West	SE 41502 01465
29	Sopranos Pizzas	925	South-West	SE 41329 01518

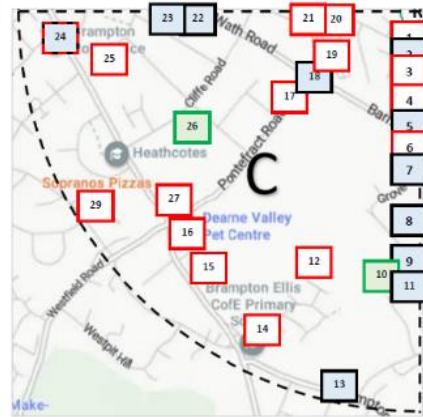

DRC-FPP-001

Derwent Recycling Centre, Sensitive Receptors Plan

04/12/2023

**QUADRANT D**

#	Receptor	Dist. M	Direction from site	Grid Reference
1	Dearne Lane	105	East	SE 42227 02006
2	Dollywood Cosmetics / Edit Surgery	270	East	SE 42381 01980
3	Tiny Tots Day Nursery	290	East	SE 42381 01980
3	Manvers Way	295	East	SE 42416 01981
4	Bauer	425	East-by-South	SE 42543 01913
5	Waterfront Golf Club	500	East	SE 42656 01990
6	Bow Wow Brigade	425	East-by-South	SE 42634 01871
6	Rotary Drive, residential	425	East-by-South	SE 42634 01871
7	Costa Coffee / KFC / Bluebell Inn	640	East-South-East	SE 42702 01734
7	Greggs / JD Sports / Onyx Fish Bar	640	East-South-East	SE 42702 01734
8	Holiday Inn Express Rotherham	995	East-South-East	SE 42998 01582
9	Whitworth Lane, residential	730	South-East	SE 42655 01524
10	football ground off Barnsley Rd]	575	South-East	SE 42528 01599
11	JET petrol garage	705	South-East	SE 52575 01466
12	Byron Lodge Care Home	805	South-South-East	SE 42549 01292
13	West Melton Primary School	960	South-by-East	SE 42347 01085
14	Premier, convenience store	715	South-by-East	SE 42274 01308
14	Marmareekas Grill / Sea Dragon, cafe	715	South-by-East	SE 42274 01308
15	Barnsley Road	340	South	SE 42109 01687
15	Barnsley Road, residential	340	South	SE 42109 01687
16	Life Skills Rotherham	255	South	SE 42102 01756
17	Ultimate Accident Repair	145	South	SE 42124 01866
18	Derwent Way	130	South	SE 42133 01877
19	Keyline Civils	100	South	SE 42135 01913

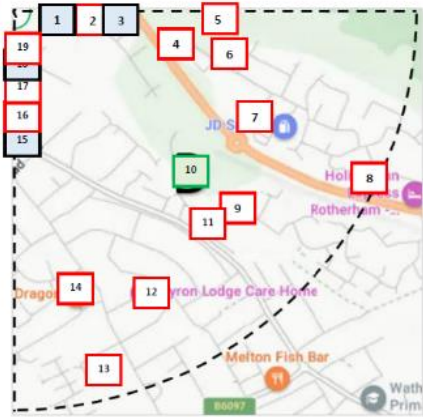

DRC-FPP-001

Derwent Recycling Centre, Sensitive Receptors Plan

04/12/2023

# DRAWING DRC-FPP-002

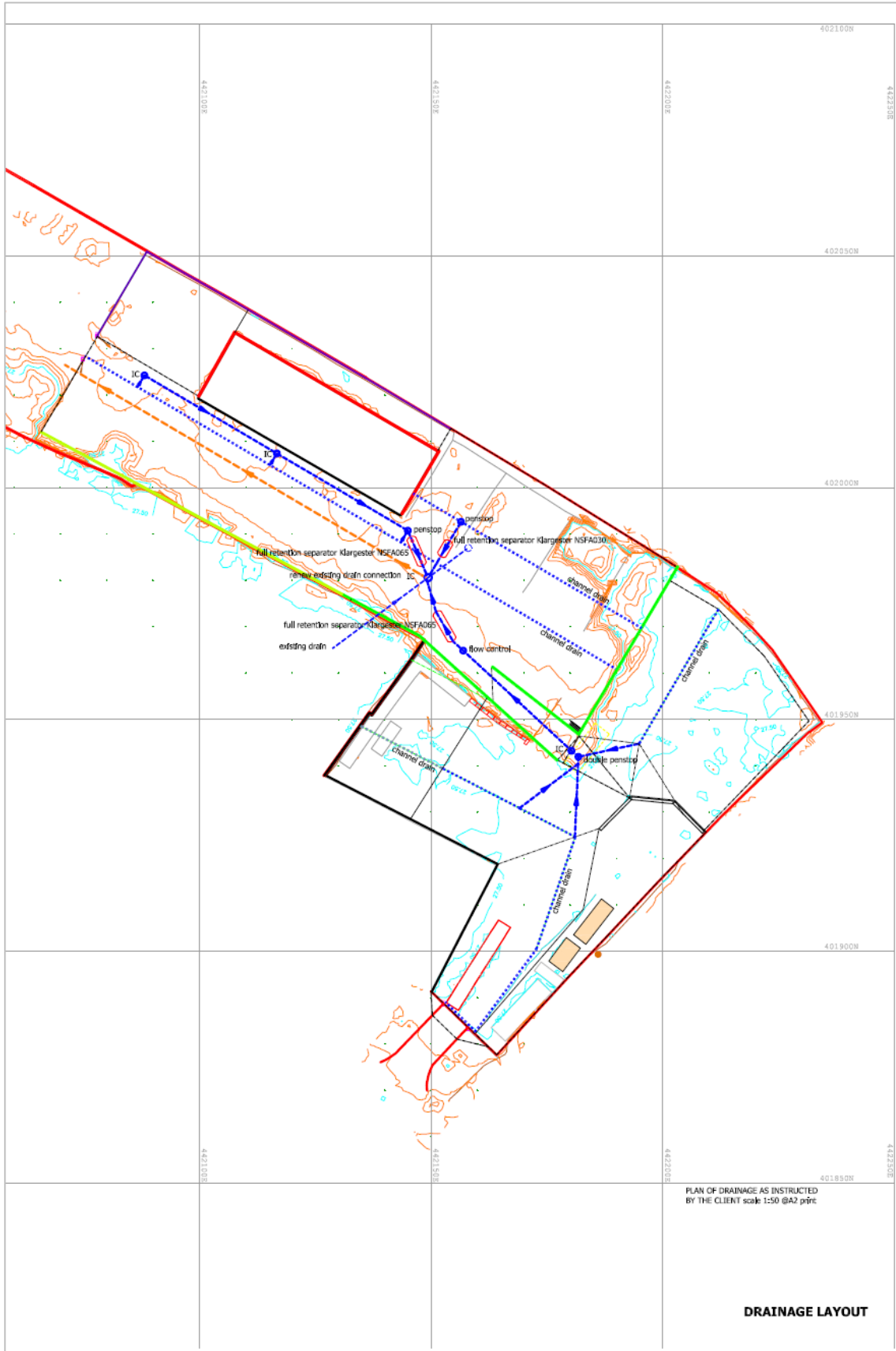

DRAWING DRC-FPP-003

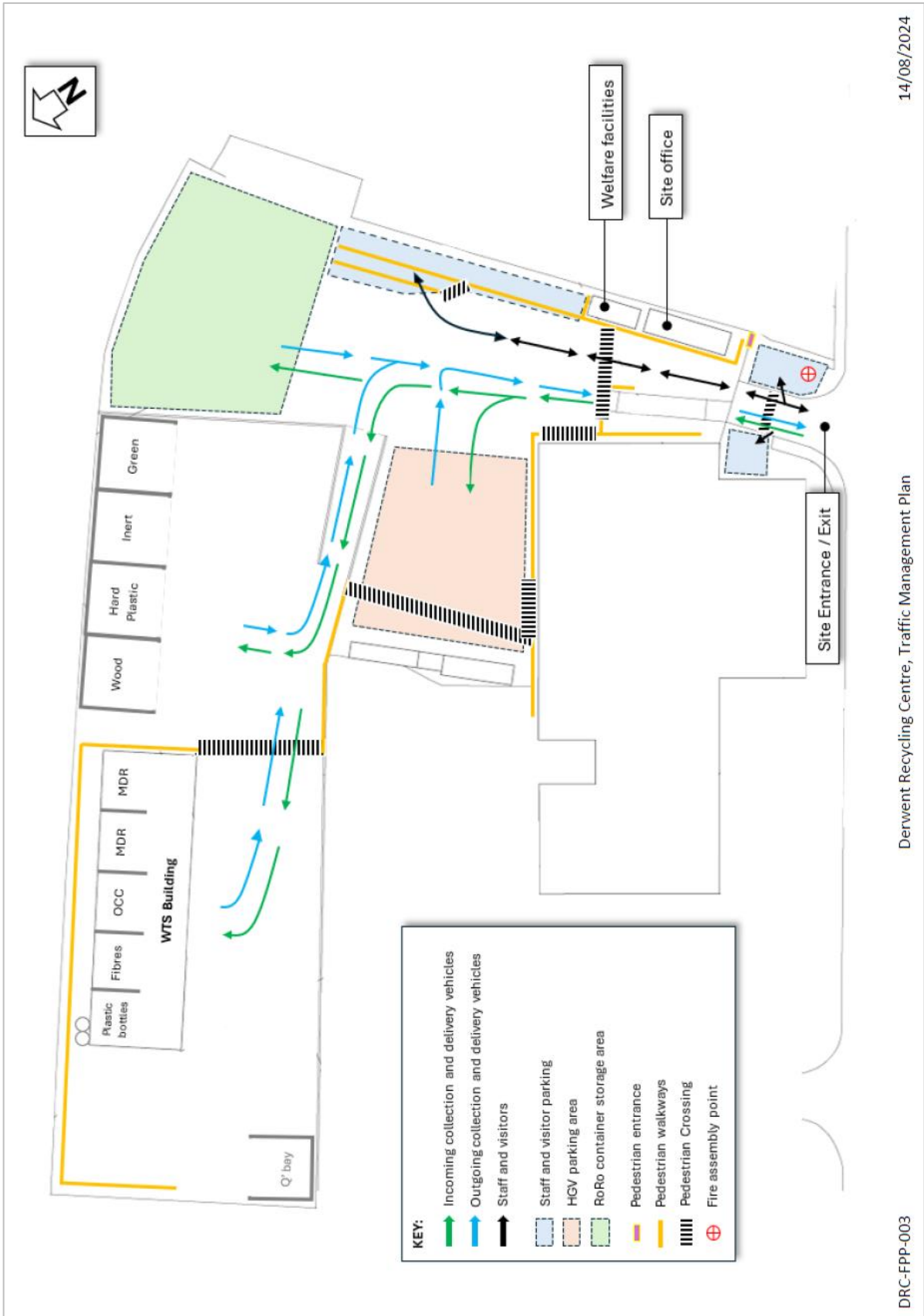

14/08/2024

Derwent Recycling Centre, Traffic Management Plan

DRC-FPP-003

DRAWING DRC-FPP-004

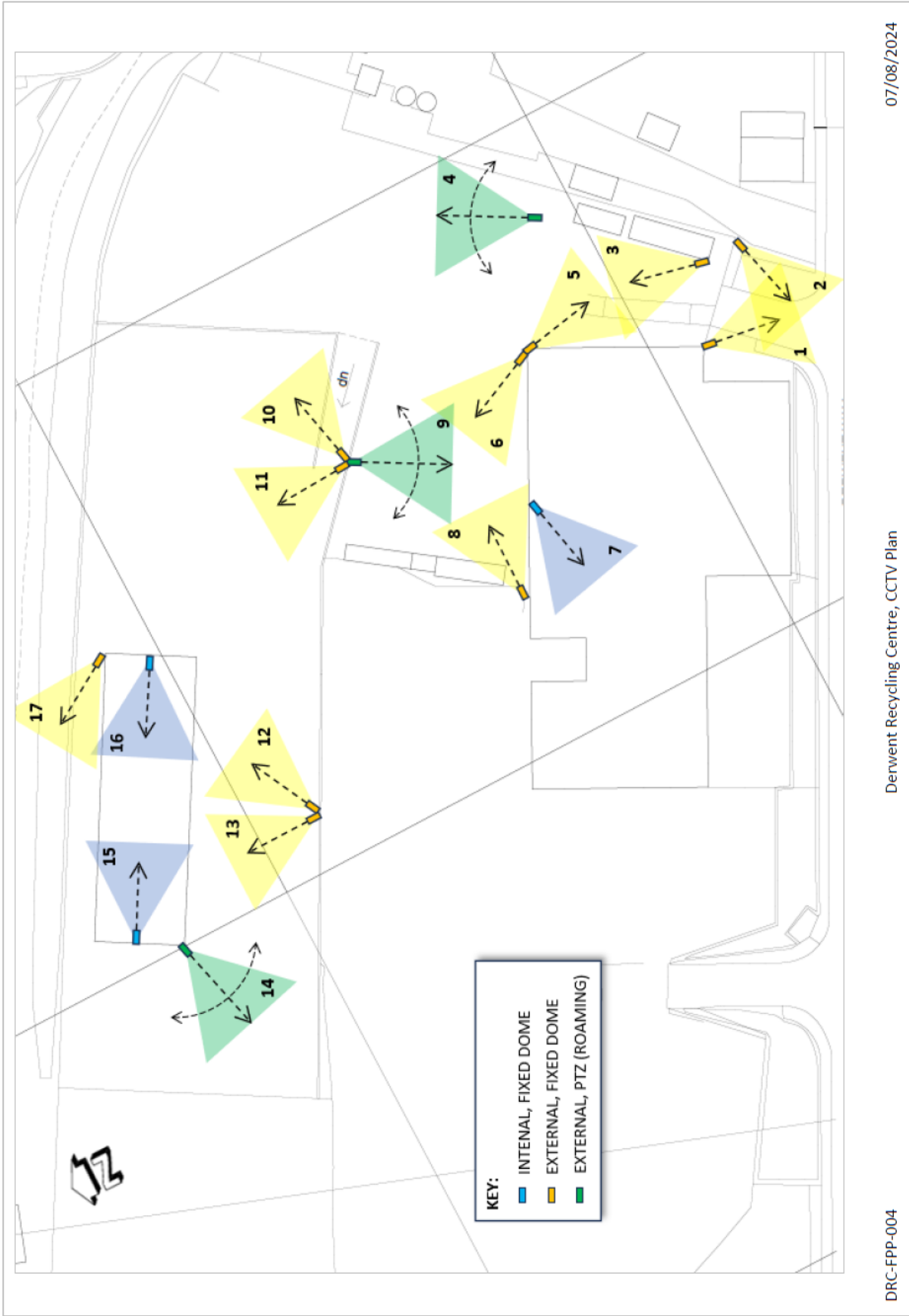

07/08/2024

Derwent Recycling Centre, CCTV Plan

DRC-FPP-004



DRAWING DRC-FPP-005

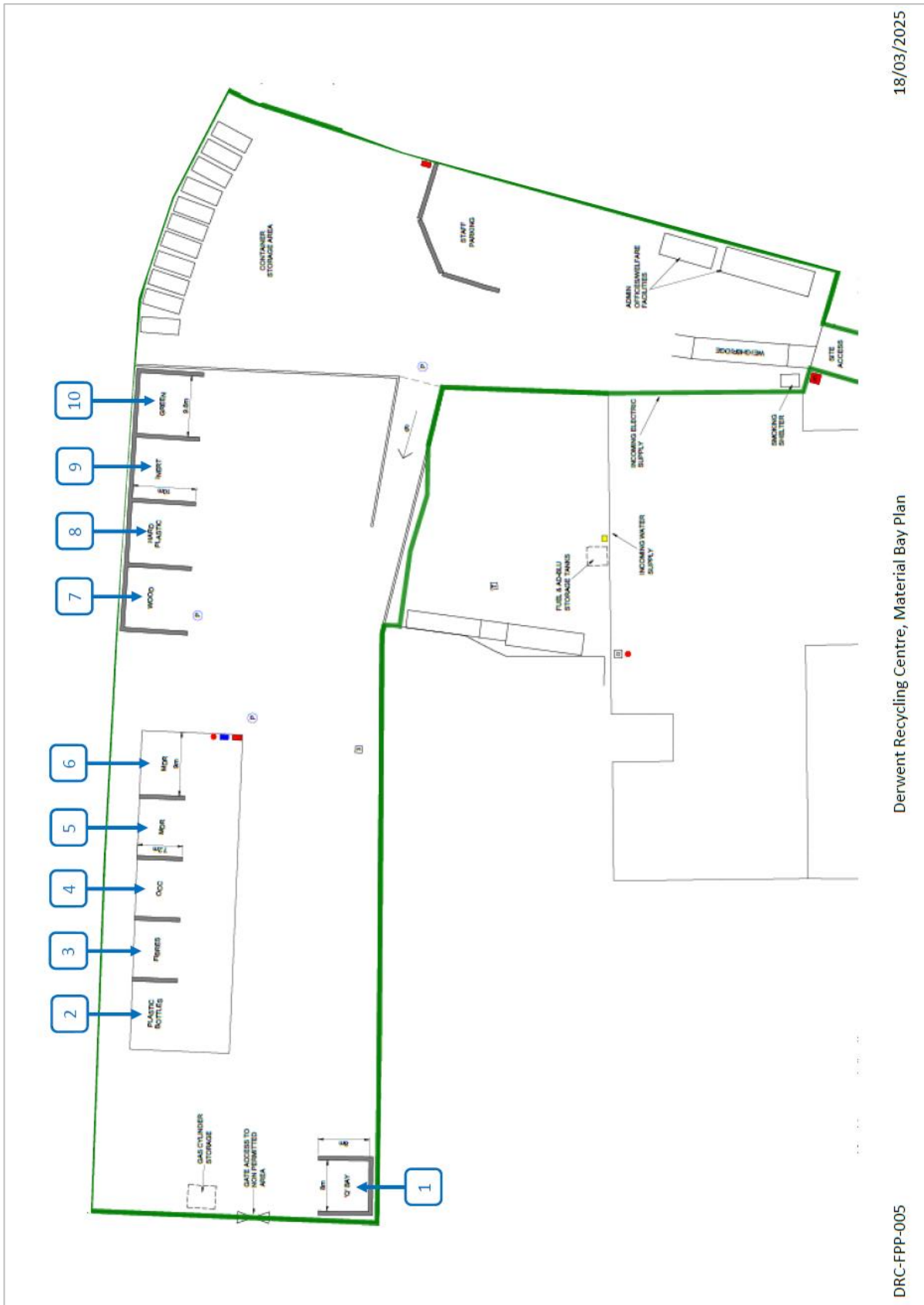

18/03/2025

Derwent Recycling Centre, Material Bay Plan

DRC-FPP-005







## APPENDICES

### Appendix 1

<b>DERWENT RECYCLING CENTRE FPP, APPENDIX 1 - WASTE STORAGE</b>										
Bay #	MATERIAL TYPE	PROCESSED / UNPROCESSED	FORM	FIREWALL, 6m SEP. DISTANCE OR CONTAINER	BAY HEIGHT / m	MATERIAL HEIGHT / m	BAY WIDTH / m	BAY DEPTH / m	MAX MATERIAL VOLUME / m <sup>3</sup>	
1	QUARANTINE	UNPROCESSED	BAGGED, BALED OR LOOSE (+150mm)	FIREWALL & 6m SEPARATION DISTANCE	4	4	8	8	256	
2	PLASTIC BOTTLES	UNPROCESSED	LOOSE (+150mm)	FIREWALL	5	4	9	7.2	259.2	
3	FIBRES (PAPER & CARDBOARD)	UNPROCESSED	LOOSE (+150mm)	FIREWALL	5	4	9	7.2	259.2	
4	OCC (CARDBOARD)	UNPROCESSED	LOOSE (+150mm)	FIREWALL	5	4	9	7.2	259.2	
5	MDR (MIXED DRY RECYCLATE)	UNPROCESSED	LOOSE (+150mm)	FIREWALL	5	4	9	7.2	259.2	
6	MDR (MIXED DRY RECYCLATE)	UNPROCESSED	LOOSE (+150mm)	FIREWALL	5	4	9	7.2	259.2	
7	WOOD	UNPROCESSED	LOOSE (+150mm)	FIREWALL	5	4	9.6	10	384	
8	HARD PLASTIC	UNPROCESSED	LOOSE (+150mm)	FIREWALL	5	4	9.6	10	384	
9	INERT	UNPROCESSED	LOOSE (+150mm)	FIREWALL	5	4	9.6	10	384	
10	GREEN WASTE	UNPROCESSED	LOOSE (+150mm)	FIREWALL	5	4	9.6	10	384	
-	VARIOUS INDIVIDUAL HWRC WASTE STREAMS	UNPROCESSED	LOOSE (+150mm)	CONTAINER (RoRos)	2.35	2.35	2.235	6.4	33.6	

# Eclipse LDX

SEE THE CLARITY.



The Best Image Quality. Ever.

Enhanced with the newest state-of-the-art infrared engine technology, the Eclipse® LDX offers the fire service the highest image quality and performance on the market.

## Bullard Xtrem

**OUTSTANDING Performance**  
The Eclipse LDX uses infrared engine technology running at an ultra-fast 60 Hertz image update rate and incorporates Image Contrast Enhancement (ICE™) technology for the ultimate image performance in fire conditions. Housed in a compact, sleek design, the Eclipse LDX is available in 240 X 180 and 520 X 240 resolutions to accommodate your budget.

## BRIGHTEST LCD Display

The new display on the Eclipse LDX greatly increases brightness and improves contrast, enabling firefighters to see more clearly in thick smoke and direct sunlight.

## ADVANCED Features

Temperature measurement in numeric and/or relative heat indicator formats and Super Red Hot colorization, highlighting high-heat scenes in brilliant shades of yellow orange and red come standard with the Eclipse LDX. Available as optional features are Bullard's patented Electronic Thermal Throttle™ that enables firefighters to pinpoint hot spots with the touch of a button and an integrated Digital Video Recorder.

## NEW Look & Feel

The Eclipse LDX is distinguishable from other thermal imagers with a cool, blue metallic swirl color. Additionally, the imager has an improved power button design that enables easier powering on and off with a gloved hand.

## FIVE YEAR Warranty

All new X Factor Thermal Imagers come standard with a five-year, industry-leading, full-service warranty on parts and labor. All new X Factor Thermal Imagers also come standard with a ten-year detector warranty.

All new batteries come standard with a two-year warranty. The outer shell is covered by a lifetime warranty, which is worldwide unique in the fire market.

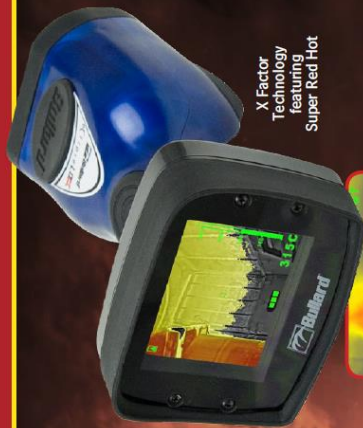

www.bullard.com

**ICE™ Image Processing**  
Equipped with ICE, the Eclipse LDX provides superior infrared imagery utilizing state-of-the-art image processing techniques. ICE technology sharpens the distinction between objects and backgrounds and optimizes the image for greater clarity. With ICE, firefighters can detect beyond the fire.

## Appendix 2

# Eclipse LDX

## Technical Specifications

### Physical

- Configuration: Small Handheld Thermal Imager
- Weight (w/ battery): 0.895 kg
- Weight (w/o battery): 0.800 kg
- Dimensions: Length: 188mm x Height: 109mm x Width: 132mm
- Housing Material: Ultra™ Thermoplastic
- Housing Color: Metallic Blue

### Electrical

- Power Source: NiMH Rechargeable Battery
- Battery Capacity: 1650 mAh
- Battery Cycles: > 800
- Start-up Time: < 4.5 seconds
- Operating Time: 2 hours\*
- Recharge Time: 2 hours

### Infrared Detector

- Detector Type: Microbolometer
- Detector Sensing Material: Vanadium Oxide
- Detector Resolution: 240 x 180 or 320 x 240
- Spectral Response: 7-14 Microns
- Update Rate: 60 Hz
- Temperature Sensitivity: < 0.05°C
- NETD: < 20 mK
- Dynamic Range: 600°C
- Pixel Pitch: 17 µm
- Video Polarity: White-Hot
- Temperature Measurement: Numeric and/or Bar-Style
- Super Red Hot: Color above 260°C

### Lens

- Material: Germanium
- Field of View: 31° Y x 40° H
- Focus: Fixed 1 meter to infinity
- Speed: 1/1.3

### Display

- Type: Digital, Liquid Crystal Display (LCD)
- Size: 3.5" Diagonal TFT Active Matrix
- Brightness: 500 cd/m<sup>2</sup> (minimum)
- Contrast Ratio: 350:1 (typical)
- Viewing Angle (Typical): Top = 60°, Bottom = 40°, Left / Right = 60°

### Features and Accessories (optionally installed in unit)

- Electronic Thermal Throttle: Manually activated Blue-Hot Spot Colorization
- SceneCatcher Digital Video Recorder
  - Video Format: NTSC
  - Video File Type: AVI
  - Video Image Size: 720 x 480
  - Video Record Time: 5 hours
  - Connection: USB
- Performance
  - 260° C Heat Resistance: 5 minutes with no damage to electronics
  - 150° C Heat Resistance: 15 minutes of continued operation with no damage
  - 29° C Cold Resistance: Continued operation
  - Water Resistance: IP67
  - Impact Resistance: Approximately 2m drops on concrete with no damage

\* With DCR operating

## Accessories



Americas:  
Bullard  
10000 W. Hwy  
Cortlandt, NY 40315-9003 USA  
Tel: +1-888-234-6136  
Fax: +1-888-234-6136

Europe:  
Bullard GmbH  
Helmholtzstr. 15  
53142, Remagen Germany  
Tel: +49-2642-999980  
Fax: +49-2642-999989

Asia-Pacific:  
Bullard Asia Pacific Pte. Ltd.  
701, Siro Drive, #04-03  
Singapore 897383  
Tel: +65-6755-0564  
Fax: +65-6755-0376

©2011 Bullard, Inc. All rights reserved.  
Eclipse and Eclipse LDX are trademarks of Bullard.  
ImageCatcher and SceneCatcher are trademarks of Bullard.  
NTSC, IP67, and DCR are trademarks of Bullard.  
Bullard is a registered trademark of Bullard.  
650 State St. (227)

www.bullard.com

### Appendix 3



**Derwent Recycling Centre**

**Environmental Log - week commencing:** / /

Daily Check List	Inspected by:	M	T	W	T	F	S	S	Comments & Actions	Completed by (Initial)
Condition of external & internal roadways <i>(Clean, free of litter and no excessive amounts of dirt / mud)</i>	Site Manager / Foreman or deputy									
Perimeter fencing and gate, barriers <i>(Operational &amp; inspection for damage)</i>										
Weighbridge <i>(Clean, any damage or wear)</i>										
Welfare facilities <i>(Clean offices, toilets, canteen etc.)</i>										
Fuel storage <i>(No leaks &amp; sufficient stock)</i>										
Oil storage area <i>(No leaks, correct storage &amp; sufficient stock)</i>										
Fire safety <i>(Fire fighting equipment in place and unused)</i>										
Spill kits <i>(In place &amp; full)</i>										
Site Drainage <i>(Free of pooling, blockages etc.)</i>										
Storage bay push walls <i>(Free of damage &amp; intact)</i>										
Penstock valve <i>(Clear / free for access)</i>										
Pest control <i>(Not an excessive presence of flies, rats etc.)</i>										
Weather condition (windy, heavy rain, icy) <i>(Details recorded in site diary)</i>										
Dust <i>(Acceptable level, not generating a nuisance)</i>										
Noise <i>(Acceptable level, not generating a nuisance)</i>										
Odour <i>(Acceptable level, not generating a nuisance)</i>										

**Additional Comments:**

---



---



---



---



---



---

**PERMIT TO WORK**

20001

**Section 1 – Permit Details & Validity**

Permit Title – From inside type of work under excavation: In section 2.  Permit Number:  Date:

Valid Only From Time:  To:

Issued To – Name Of Contractor:

Job Location – Enter Area Where Permit Is Valid:

Plant Identification – Identify Plant Or Equipment Where Permit Is Valid:

Description Of Work To Be Carried Out:

**Section 2 – Precautions Necessary**

Type Of Work	Safety Check	Yes/No
<b>Electrical</b> (Controls to be determined by risk assessment)	Lock-off capacitor / bypass and key to be used. Attach controls notice / tag. Test power isolated / system proved dead. Do not carry out live electrical work on this permit	
<b>Mechanical</b> (Controls to be determined by risk assessment)	Shut and lock off valves Drain systems Purge system Spindle system Check for residual pressure / energy in system before removing isolation	
<b>Hot work</b> (Controls to be determined by risk assessment)	Area to be free of flammable materials / liquids or protected by fire blanket No potential sources of flammable substances within 10 metres of work Two fire extinguishers to be used Fire watch set – check 15, 30 & 60 minutes after work completed Second man required Area to be well ventilated Welding screens to be erected (controls / posters by) Keep oxygen cylinders away from sparks Do not use acetylene inside vessels, over sewers / drains or on tanks / drums Fire watch set – check 15, 30 & 60 minutes after work completed All services and utilities identified / services plan available	
<b>Excavation</b> (Controls to be determined by risk assessment)	Call Scan required and carried out Final pit limit sign Cable runs marked	

**Section 3 – Authorisation – Confirm Isolations/safety precautions have been taken**

HWM Manager Name:  Signature:

**Section 4 – Receipt and Acceptance of Permit**

I HAVE READ THIS FORM AND UNDERSTOOD THE SPECIAL PRECAUTIONS TO BE TAKEN PRIOR TO AND DURING WORK

Contractor Name:  Signature:

Additional persons authorised to work under this permit – Sign to confirm understanding of permit requirements

Name	Responsibility	Signature

**THE WORK CAN NOW BE CARRIED OUT**

**Section 5 – Extension/Shift Change Over**

HWM Manager Name:  Signature:

Contractor Name:  Signature:

**Section 6 – Hand Back - Completion Of Work /Commissioning**

HWM Manager Name:  Signature:

Contractor Name:  Signature:

**Section 7 – Cancellation – Permit Closed All Work Tested And Plant Re commissioned**

HWM Manager Name:  Signature:

**Section 8 – Notes**

HWM Management System  
Approved by IM 1 of 1 Issue 26/01/2007

Permit to Work HSP1

Work at Height  
>5m (Controls to be determined by risk assessment)  
Safe access and egress  
Safe working platform  
Suitable edge protection  
Fall arrest harness and/or safety rope.

Confined Spaces  
(Control of spaces are defined under the Confined Spaces Regulations)  
ALL ENTRY INTO CONFINED SPACES MUST BE AUTHORIZED BY THE GROUP HEALTH & SAFETY MANAGER. A SEPARATE PERMIT TO WORK WILL BE ISSUED.

Protective Equipment – Detail PPE And Other Protective Equipment To Be Used

**MARTIN**  
GROUP OF COMPANIES

**PERMIT TO WORK**

20001

**Section 1 – Permit Details & Validity**

Permit Title – From inside type of work under excavation: In section 2.  Permit Number:  Date:

Valid Only From Time:  To:

Issued To – Name Of Contractor:

Job Location – Enter Area Where Permit Is Valid:

Plant Identification – Identify Plant Or Equipment Where Permit Is Valid:

Description Of Work To Be Carried Out:

**Section 2 – Precautions Necessary**

Type Of Work	Safety Check	Yes/No
<b>Electrical</b> (Controls to be determined by risk assessment)	Lock-off capacitor / bypass and key to be used. Attach controls notice / tag. Test power isolated / system proved dead. Do not carry out live electrical work on this permit	
<b>Mechanical</b> (Controls to be determined by risk assessment)	Shut and lock off valves Drain systems Purge system Spindle system Check for residual pressure / energy in system before removing isolation	
<b>Hot work</b> (Controls to be determined by risk assessment)	Area to be free of flammable materials / liquids or protected by fire blanket No potential sources of flammable substances within 10 metres of work Two fire extinguishers to be used Fire watch set – check 15, 30 & 60 minutes after work completed Second man required Area to be well ventilated Welding screens to be erected (controls / posters by) Keep oxygen cylinders away from sparks Do not use acetylene inside vessels, over sewers / drains or on tanks / drums Fire watch set – check 15, 30 & 60 minutes after work completed All services and utilities identified / services plan available	
<b>Excavation</b> (Controls to be determined by risk assessment)	Call Scan required and carried out Final pit limit sign Cable runs marked	

**Section 3 – Authorisation – Confirm Isolations/safety precautions have been taken**

HWM Manager Name:  Signature:

**Section 4 – Receipt and Acceptance of Permit**

I HAVE READ THIS FORM AND UNDERSTOOD THE SPECIAL PRECAUTIONS TO BE TAKEN PRIOR TO AND DURING WORK

Contractor Name:  Signature:

Additional persons authorised to work under this permit – Sign to confirm understanding of permit requirements

Name	Responsibility	Signature

**THE WORK CAN NOW BE CARRIED OUT**

**Section 5 – Extension/Shift Change Over**

HWM Manager Name:  Signature:

Contractor Name:  Signature:

**Section 6 – Hand Back - Completion Of Work /Commissioning**

HWM Manager Name:  Signature:

Contractor Name:  Signature:

**Section 7 – Cancellation – Permit Closed All Work Tested And Plant Re commissioned**

HWM Manager Name:  Signature:

**Section 8 – Notes**

HWM Management System  
Approved by IM 1 of 1 Issue 26/01/2007

Permit to Work HSP1

Work at Height  
>5m (Controls to be determined by risk assessment)  
Safe access and egress  
Safe working platform  
Suitable edge protection  
Fall arrest harness and/or safety rope.

Confined Spaces  
(Control of spaces are defined under the Confined Spaces Regulations)  
ALL ENTRY INTO CONFINED SPACES MUST BE AUTHORIZED BY THE GROUP HEALTH & SAFETY MANAGER. A SEPARATE PERMIT TO WORK WILL BE ISSUED.

Protective Equipment – Detail PPE And Other Protective Equipment To Be Used



VEHICLE SCHEDULE

Close Save Delete Vehicle Export Preview

Main Details | Vehicle Dates | Vehicle History | Sales Analysis | Maintenance Schedule | Vehicle Notes | Attachments (2) | Rental History | Audit Details

Schedule Type	Interval	Frequency	Last Mileage	Last Date	Next Date
SM P3 INSPECTION	8	Weeks	2250	13-03-2020	04-05-2020
MOT	1	Years			
2 Yr Tacho Calibration	2	Years			
6 Yr Tacho Calibration	6	Years			
Reduced Pollution Check	1	Years			
Tail Lift Check	1	Years			
Insurance Exam	1	Years			31-05-2020
Crane Service A	Vehicle_Specific	Weeks			
Body/Skip Gear	6	Weeks			
Road Fund License	1	Years			
TMATA INSPECTION	6	Months			
Check Mileage	1	Years			
Crane Service C	1	Years			

**Vehicle Dates**

[Resynch Next Dates From Schedule](#)

First Taxation Date: 01 January 1900  
 '0' License Expiry: 01 January 1900

**Warranty Information**

Manufacturer Warranty Description:   
 Warranty Years:   
 Warranty Expiry Date: 01 January 1900  
 Authority Limit:

**Contract Maintenance**

Description:

HW Martin (Plant) Ltd



Policy & Procedure Title	Name	Title	Signature	Date
MRF & WTS WASTE ACCEPTANCE				
Author	K Brough	Compliance Manager	<i>Karl</i>	14.02.2023
Reviewer	D Nortcliffe	Operations Director	<i>D Nortcliffe</i>	14.02.2023
Authoriser	R Akers	Director	<i>R Akers</i>	14.02.2023

Effective Date:	Sep 2022
Review Date:	As required

### 1. PURPOSE

The purpose of this policy and procedure (P&P) is to establish a formal process to be followed when accepting waste materials at our Materials Recycling Facilities and Waste Transfer Stations.

### 2. INTRODUCTION

The company has an established process for accepting waste materials; this P&P formalises the process in order that it can be followed consistently and effectively by our site staff.

This policy and procedure (P&P) also ensures the Company is meeting the criteria set out in the waste Duty of Care code of practice.

### 3. SCOPE

The P&P applies to all waste materials received at our Materials Recycling Facilities and Waste Transfer Stations. Company activities that may give rise to receiving such waste materials comprise:

- The management and operation of HWRCs (Household Waste Recycling Centres, also known by other names such as tips, civic amenity sites etc.)
- The management and operation of MRFs (Materials Recycling Facilities)
- The management and operation of WTSs (Waste Transfer Stations)
- The management of commercial / trade waste by Premier Waste Recycling
- The treatment of Local Authority MDR (Mixed Dry Recyclate)

### 4. DEFINITIONS

**4.1 D.O.C**  
Duty of Care - our legal responsibility to ensure that we produce, receive, store, transport and dispose of our waste without harming the environment.

#### 4.2 Environmental Permit



A type of licence that is required if from a result of your activity, you pose a risk of (i) causing an emission which could result in pollution to air, water or land, (ii) increased flood risk or (iii) which could adversely affect land drainage.

#### 4.3 HWRC

Household Waste Recycling Centre - a permitted facility that accepts waste from the public and (in some cases) from a commercial business on behalf of a local authority.

#### 4.4 Load

The contents of any vehicle which is intended to be deposited at the Materials Recycling Facility.

<p><b>H.W. MARTIN WASTE LTD. POLICY &amp; PROCEDURE INTEGRATED MANAGEMENT SYSTEM ISO 9001:2015, 14001:2015 &amp; 45001:2018</b></p>  <p><b>4.5 Local Authority</b> An administrative body in local government, sometimes referred to internally as the client or council.</p> <p><b>4.6 MRF</b> Materials Recycling Facility - a permitted facility that accepts and treats / separates mixed waste materials from commercial businesses or Local Authorities (councils)</p> <p><b>4.7 Waste Exemptions</b> Required for a waste operation that is exempt from needing an Environmental Permit. Similar to a permit, waste exemptions still have specific limits and conditions that the holder must operate within.</p> <p><b>4.8 Waste Transfer Station</b> A facility where municipal waste is delivered into for baling, shredding, sorting and / or storage before sent on for further treatment or disposal.</p> <p><b>5. RESPONSIBILITIES</b> <b>Business Support Manager (Compliance):</b> responsible for assisting the Operations Director in organising the safe removal of non-conforming waste from site in the absence of the compliance Manager. <b>Director:</b> responsible for authorising the issue of Integrated Management System (IMS) policies and procedures of H.W Martin Waste and controlled documents directly related to the Waste company's transport activities. <b>Compliance Manager:</b> responsible for assisting the Operations Director in organising the safe removal of non-conforming waste from site and, for advising the Environment Agency of any possible emissions beyond the site's permit boundary as a result of any non-conforming wastes. <b>Machine driver (tele-handler operator):</b> responsible for checking all tipped waste materials for non-conforming waste and for communicating this to the weighbridge operator. <b>Operations Director:</b> responsible for overall day-to-day activities for our HWRCs, MRFs and WTSs and for communicating the details of any waste rejections to the relevant Local Authority or customer. <b>Site / Operations Manager:</b> responsible for completing the MRF &amp; WTS Waste Rejection Form in a timely fashion and for sending this (together with any supporting information) to the Operations Director and Compliance Manager. Also responsible for communicating any potential risk of emissions (such as odour and pests) beyond the sites permit boundary to the Operations Director and the Compliance Manager. <b>Weighbridge Operator:</b> responsible for ensuring the waste description is correct in the documentation supplied by the producer and holder for all materials received on site and, for communicating details of any non-conforming waste to the Site / Operations Manager.</p> <p style="text-align: right;">WA-IMS-ENV-PR-006_V2.0      Page 3 of 5</p>	<p><b>H.W. MARTIN WASTE LTD. POLICY &amp; PROCEDURE INTEGRATED MANAGEMENT SYSTEM ISO 9001:2015, 14001:2015 &amp; 45001:2018</b></p>  <p><b>6. SPECIFIC PROCEDURE</b> The content or specification of 'conforming' waste materials to be received at the MRF or WTS is agreed at the start of a contract and / or during the contract extension process. Wastes will only be accepted when the site is operational and when staff are present to inspect the material tipped. The delivery of waste materials from our HWRCs or commercial customers delivered into our MRFs or WTSs will be agreed in advance and these waste materials should be as described / agreed. When any waste arrives on site, the associated documentation will be checked by the Weighbridge Operator to ensure the waste description is correct and that it is an accepted waste included in the site's Environmental permit or registered waste exemptions. Materials that cannot be accepted will be rejected from site. Conforming wastes will be stored in the relevant bay and bulked ready for onward transfer for processing or for treatment / processing on site or will be loaded directly into the line for treatment / processing. In the event that a non-conforming (unauthorised) waste is identified within Local Authority material by site staff during load discharge / offloading, then the following action will be taken:</p> <ul style="list-style-type: none"> <li>• The load will be segregated from other materials in an isolation area or quarantine bay.</li> <li>• Site staff will inform the Weighbridge Operator and Site / Operations Manager.</li> <li>• The Site / Operations Manager will take photographic evidence and complete the MRF &amp; WTS Waste Rejection Form before sending this information over to the Compliance Manager and Operations Director.</li> <li>• Any non-conforming waste likely to cause an emission beyond the site's permit boundary (such as odour or pests) will be communicated to the Environment Agency by the Compliance Manager.</li> <li>• The isolated / quarantined load will be made available for inspection by the Local Authority and (where applicable) the Environment Agency on request.</li> <li>• An appropriate disposal route will be agreed with the Local Authority and / or the Environment Agency before it is transferred to a permitted treatment or disposal facility.</li> </ul> <p>If non-conforming (unauthorised) waste is found within a load of material delivered to site and it is possible to safely remove this waste material, it will be placed in an isolation area or quarantine bay. The customer or Local Authority and the relevant Contract Manager will be informed before suitable arrangements are made to remove this non-conforming (unauthorised) waste material from site.</p> <p style="text-align: right;">WA-IMS-ENV-PR-006_V2.0      Page 4 of 5</p>
---	---

**MRF & WTS  
Waste Rejection Form**



**Site Receiving Waste**

*\*Please tick appropriate box*

ARC  DRC  Leeds  MRC  Monument Park  Sandbach

**Details of the Load**

Delivery date    Time of delivery

Name of Customer

Material delivered in

Haulier | Vehicle registration

**Reason for Rejecting Waste**

*\*Please tick all appropriate boxes*

Legal : Waste type, presence of non-conforming waste

Legal : Waste description, wrongly coded & non-acceptable

Environmental : Presence of hazardous waste material

Environmental : Presence of dusty waste material

Environmental : Presence of odorous waste material

Operational : Presence of files or vermin in the waste

Operational : Presence of oversized waste material

Other :

Comments:

**Delivery Driver Details**

Name  Signature

**Person Completing this Form**

Name  Signature

Please ensure photographic evidence is taken and that this form together with the photographs and any weighbridge ticket generated are passed over to the Compliance Manager and Operations Director ASAP.

WA-IMS-ENV-FO-007\_V3.0 01.11.2023

H.W. MARTIN WASTE LTD.  
POLICY & PROCEDURE  
INTEGRATED MANAGEMENT SYSTEM  
ISO 9001:2015, 14001:2015 & 45001:2018



Completed MRF & WTS Waste Rejection Forms and any supporting information (such as pictures, documentation, and emails) will be retained by the Company for a minimum of 2 years for non-hazardous wastes and 3 years for hazardous wastes.

7. **FORMS/TEMPLATES TO BE USED**  
WA-IMS-ENV-FO-007, MRF & WTS Waste Rejection Form

8. **INTERNAL AND EXTERNAL REFERENCES**

- 8.1 **Internal References**
- Alfreton Recycling Centre Site Management Plan
  - Leeds Materials Recycling Facility Management System
  - Monument Park Site Management Plan
  - Sandbach Management Plan

8.2 **External References**

- Environment Agency code of practice & guidance: [www.gov.uk](http://www.gov.uk)
- Waste duty of care: code of practice (accessible version) - GOV.UK [www.gov.uk](http://www.gov.uk)
- Waste acceptance procedures for deposit for recovery - GOV.UK [www.gov.uk](http://www.gov.uk)

9. **CHANGE HISTORY / DOCUMENT REVIEW**

Revision no.	Effective Date	Significant Changes	Previous Revision no.
1.0	09.09.2022	Initial issue / revision	N/A
2.0	14.02.2023	Title of document amended, minor amendments to content to include 'WTS' reference and Monument Park, the inclusion of managing PAIR commercial waste in section 3, Storage & Management Plans included in section 8.1.	1.0

## Appendix 4



rev. 02/2013

### EUROPEAN STANDARD

European Standard EN 13501-1 provides the reaction to fire classification procedure for all products and building elements. According to this Standard, reaction to fire is the response of a product in contributing by its own decomposition to a fire to which it is exposed, under specified conditions (not to be confused with the fire resistance).

Products are considered in relation to their end use application are divided into three main categories:

- construction products;
- flooring;
- linear pipe thermal insulation products (not considered here).

Construction products are classified according to harmonized test methods in Euroclasses A1, A2, B, C, D, E and F.

Products classified in a given class are deemed to satisfy all the requirements of any lower class.

Products classified in A1 and A2 classes are non-combustible (cement, concrete, minerals, glass, fiberglass, rock wool, ceramic, etc.), materials certified from B to F are combustible in ascending order.

Flooring materials are classified according to the same classes A1, A2, B, C, D, E and F followed by the abbreviation "fl" flooring.

Definition	Classification according to European Standard EN 13501-1				
	Construction products			Floorings	
	A1			A1 <sub>fl</sub>	
non-combustible materials	A2 - s1 d0 A2 - s2 d0 A2 - s3 d0	A2 - s1 d1 A2 - s2 d1 A2 - s3 d1	A2 - s1 d2 A2 - s2 d2 A2 - s3 d2	A2 <sub>fl</sub> - s1	A2 <sub>fl</sub> - s2
combustible materials - very limited contribution to fire	B - s1 d0 B - s2 d0 B - s3 d0	B - s1 d1 B - s2 d1 B - s3 d1	B - s1 d2 B - s2 d2 B - s3 d2	B <sub>fl</sub> - s1	B <sub>fl</sub> - s2
combustible materials - limited contribution to fire	C - s1 d0 C - s2 d0 C - s3 d0	C - s1 d1 C - s2 d1 C - s3 d1	C - s1 d2 C - s2 d2 C - s3 d2	C <sub>fl</sub> - s1	C <sub>fl</sub> - s1
combustible materials - medium contribution to fire	D - s1 d0 D - s2 d0 D - s3 d0	D - s1 d1 D - s2 d1 D - s3 d1	D - s1 d2 D - s2 d2 D - s3 d2	D <sub>fl</sub> - s1	D <sub>fl</sub> - s1
combustible materials - highly contribution to fire	E		E - d2	E <sub>fl</sub>	
combustible materials - easily flammable	F			F <sub>fl</sub>	

### Additional classifications

All the materials classified A2, B, C, D obtain an additional classification regarding the emission of smoke and the production of flaming droplets and/or particles.

- "s" Smoke emission level:  
values range from 1 (absent/weak) to 3 (high)

- "d" flaming Droplets and/or particles production:  
values range from 0 (absent) to 2 (high)

Additional class	Level definition
smoke emission during combustion	s 1 quantity/speed of emission absent or weak
	s 2 quantity/speed of emission of average intensity
	s 3 quantity/speed of emission of high intensity
production of flaming droplets/particles during combustion	d 0 no dripping
	d 1 slow dripping
	d 2 high dripping

For the E class is provided one single subclass d2.

For flooring products is provided the additional classification "s" for smoke emission only.

NOTE: the text above is a simplification of the current national and European Standards. It exclusively has an informative value and it has the only purpose to facilitate the understanding on the use of flameproof materials for scenography produced by Peroni S.p.a. which is in no case responsible for the accuracy of the information and/or for a misinterpretation.



**Title:**

The fire resistance performance of a non-loadbearing, wall assembly tested in accordance with BS 476: Part 22: 1987, Clause 5

**WF Report No:**

397322



**Prepared for:**

Poundfield Products Limited  
The Grove, Creeting ST.,  
Peterborough,  
Suffolk,  
IP6 8QG.

**Date:**

23<sup>rd</sup> August 2018



0249

## Summary

**Objective** To determine the fire resistance performance of a non-loadbearing wall assembly when tested in accordance with Clause 5 of BS 476: Part 22: 1987.

**Sponsor** Poundfield Products Limited, The Grove, Creeting ST., Peterborough, Suffolk, IP6 8QG.

**Summary of Tested Specimen** The test assembly had overall nominal dimensions of 3035 mm high by 3000 mm wide by 100 mm thickness and comprised three horizontally joined concrete panels. The edges of the panels were profiled such that they interlocked.

The specimen was fixed to the furnace restraint frame along the top and bottom and one vertical edge.

**Test Results:**

<b>Integrity</b>	132 minutes
<b>Insulation</b>	132 minutes
<b>Date of Test</b>	The test was discontinued after a period of 132 minutes. 13 <sup>th</sup> May 2018.

# Stratos®

ASPIRATING SMOKE DETECTORS

## Introduction to: Aspirating Smoke Detection Stratos-HSSD

### What, Why and Where

**What**  
Aspirating smoke detection (also known as Air Sampling) is a method of smoke detection, whereby a sample of air is continuously drawn from the protected area through a network of sampling pipes, and passed through a laboratory designed laser detection control.

The output of this detection system is processed by a powerful system of "Artificial Intelligence" which provides the maximum of sensitivity without the risk of false alarms.

**Why**  
Aspirating smoke detection is not intended to compete with standard point detectors, which is suitable for most standard applications where cost and basic compliance to regulations are the main drivers.

However, there are many instances where a more effective and reliable form of detection is required or point detectors do not fit the situation. ASD offers the only solution in these circumstances, applications which are in high risk and high value areas that have high levels of sophistication for ASO.

- Where early warning is required
- Where high air flow (air conditioning) is present
- Where environment is hostile (very cold, very hot, wet or dusty)
- Where detection is to be covert (discrete)
- Where building layout will cause smoke stratification
- Where access for maintenance is impractical
- Where conventional detection is required for codependent release

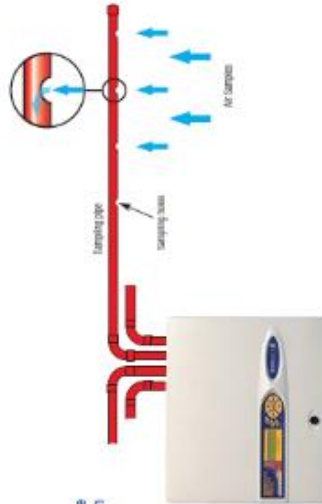

Aspirating Smoke Detection

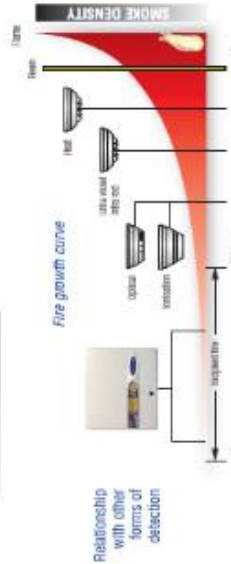

**Where**

**Early warning:** Laser based aspirating smoke detection can be up to thousands times more sensitive than point detection systems. Other aspirating systems which use a "point" type detector in an aspirating network (also known as PAE - point in a body, where such a detection system is coupled with Control Panel Perceptive Artificial Intelligence (PAI) system, as used in Stratos-HSSD), enables the system to provide and maintain the optimum sensitivity without external input, maintaining sensitivity and eliminating nuisance alarms.

- Protection of high value assets
- Computer cabinet protection
- Computer room protection
- Museums

**Areas of high airflow:** Cook, Catering, air-con conditioning systems as used in many modern environments apply relatively high velocity air currents, which effectively prevent smoke from being able to settle conventionally. Point type detectors (generally used where there is no "recuper" fan, when the recirculation thermal frequency is 100 to 1000 times conventional) will not be able to detect smoke. Aspirating systems, however, are able to detect smoke in the airflow in front of the air conditioning intake grille or duct. This not only provides for smoke detection, it also makes use of the airflow to transport the cool smoke from an incident directly to the detection system, providing the most certain and quickest of responses. This is method of application is known as Primary Detection: continuous applications:

- Computer suites (IT rooms)
- Telephone exchanges
- Clean rooms

**Hostile environments:** By nature of the system, an aspirating smoke detection system such as Stratos-HSSD has no need to be located where the area to be protected as the air is transported to the detector via sampling pipes. This means ASD can often be used in areas of extreme heat, cold and humidity.

- Cold stores
- Food preparation areas (when down areas subject to condensation)
- Areas of high humidity (such as drying rooms)
- Ice-rink plants - subject to corrosion
- The Stratos-HSSD range of detectors incorporates dust compensation and laser cut-off discrimination (LCO™). This means that it is possible to provide highly sensitive smoke detection in most dust liable or environments with minimum risk of false alarms.

- Health areas
- Pipework areas / Issue production
- Production and storage condensation
- High humidity
- High temperature
- Mains supply (e.g.)
- Cable tunnels
- Cold storage

**Covert detection:** Where detection is required but for reasons of cost or a system of passive ventilation, it must not be visible. A continuous air sample can be discreetly drawn via capillary tubes which are either high temperature or otherwise concealed in ceiling beams such as light fittings.

- Heritage buildings (cathedral, palace etc.)
- Prison cells / correction centres
- Art galleries and museums

**High ceilings and smoke stratification:** Due to the effect of stratification, in buildings with a ceiling height in excess of 12 metres, unless a fire has reached

congregation stage, it is unlikely that smoke will rise high enough or quickly enough to enable roof-mounted point detectors to provide effective protection. Maintenance of ceiling mounted point detectors can also be a problem, requiring special access equipment. Beam detectors are commonly used in this application, but these are of limited life span, and do not provide early warning, they are also intrinsically safe to basic circuits. One to "building footprint and possible above activity" for protection of the building. Smoke detection systems can be used at various positions throughout the area and participate in a VERTICAL, sense. This sense an aspirating system to provide early warning, inspection of the need of notification.

- High warehouses or distribution centres
- Airline bases
- Heli pads
- Shopping / retail sites
- Aircraft hangars

**Where access for detector maintenance is a problem:** Smoke detectors generally need maintaining and testing every 6 months. This can be impractical for point detectors in a large number of applications, or access equipment might be required or areas of limited height. For access equipment, obstacles can be used to prevent the problem area when maintenance is due:

- High buildings
- Road streets
- Hospitals
- Carling and other roof voids
- Escalators
- Supermarkets

**Fire extinguishing system release:** Causes of fire often result in the release of gaseous fire extinguishing systems such as two types of foam or halon, which are extinguishing gas that is released. This is known as "contaminator or opaque smoke detector". Because of the toxicity and performance of such gases, it is generally preferred to use a point detector. The second step in detection is to use an aspirating smoke detector. There are two ways to do this: one is to use a point detector to confirm release of gas.

- Exposed control units
- Substations
- Computer areas
- Server rooms
- Telecom areas

It is important to appreciate that in many cases, the application of high sensitivity aspirating smoke detection, providing the incident the detection means that they are able to return intervention as such an early stage of fire that a fire is PREVENTED, rather than merely being detected. This minimises damage, reduces downtime and prevents harm to personnel at the environment.

**Associated data sheets and details**

- Category 1 Perceptive Artificial Intelligence
- LAMP (Laser Monitoring) (LAMP-1000)
- Application Guide
- Product Data Sheet

**Air Science Technology Limited** - 503, 21st - UK  
 1 Century Place - Century Way - Woking - Surrey - GU24 0NF  
 Tel: +44(0)1483 751264 - Fax: +44(0)1483 729137  
 e-mail: [cust@airscience.co.uk](mailto:cust@airscience.co.uk) - [www.airsciencetechnology.com](http://www.airsciencetechnology.com)

**Air Science Technology Limited (Hong Kong)**  
 11801 Wing On Central Building - 26/F - 26/Venue Road Central - Central (Hong Kong)  
 Tel: (852) 2461 4201 - Fax: (852) 2461 4717  
 Email: [hk@airscience.com.hk](mailto:hk@airscience.com.hk)

Copyright © 2017 Air Science Technology Ltd.  
 Stratos, HSSD, MSA and Cloud Fire are registered  
 trademarks of Air Science Technology Ltd.

# Stratos<sup>®</sup> PS25 Power Supply

Aspirating Smoke Detection  
system modelling program



### Description

PipeCAD™ is a Computer Aided Design tool that is used to model the aspirating smoke detector and sampling pipe network and predict performance. Pipe networks can be easily and simply drawn onto a 'snap grid' in either 2D or three dimensional formats as needed using simple easy to use design tools. Once the sampling pipe network has been defined, performance characteristics can be adjusted to provide optimum results to suit site conditions and/or specification requirements.

### Key Features

- Import .dwg building outlines.
- Choose fixed hole sizes or best flow balance to suit site performance requirements.
- Selectable 3D isometric or 2D plan views.
- Tee pipe 'spurs' supported to suit most sampling pipe networks and retrofit applications.
- Selectable Print format for full calculation report or individual pages for each pipe.
- Pipe toucher simplifies basic tasks such as adding or deleting sampling holes etc.
- Adjustable sampling pipe sizes to suit a range of installation materials.
- Automatically generated bill of materials.

### Approval

Approved/used by most major international fire protection certification agencies. (contact AirSense Technology for latest details).

### SPECIFICATIONS

Minimum Specification PC:	Windows™ 95,
	98, 2000, NT or XP
	Intel Pentium 133 Mhz
	16Mb RAM
	4x-speed CD ROM
	10Mb Hard disk space

### ORDERING INFORMATION

Part No.	Description
30211	PipeCAD™ Sampling Pipe Modelling Software or download free from <a href="http://www.airsensetechnology.com">www.airsensetechnology.com</a>
30206	US Market Version

Copyright © 2007 AirSense Technology Ltd. Stratos, R510, Micro and ClassFire are registered trademarks of AirSense Technology Ltd.

1 Canton Place - Canton Way - Stoverage - Herts - SG7 2JG - UK  
 e-mail: [sales@airsense.co.uk](mailto:sales@airsense.co.uk) [www.airsensetechnology.com](http://www.airsensetechnology.com)

1801 Wing On Central Building - 26 Des Voeux Road Central - Central Hong Kong  
 Tel: (852) 2561 4206 • Fax: (852) 3007 4737  
 e-mail: [keon.hubb@airsense.co.uk](mailto:keon.hubb@airsense.co.uk)

# Stratos<sup>®</sup> PS25 Power Supply

ASPIRATING SMOKE DETECTORS

### Description

The PS25 is designed to provide a versatile solution for powering aspirating smoke detectors. A high capacity intelligent 2.5 Amp power supply provides current for 'top to tail' remote operation while charging the 'back-up' batteries for use in the event of a power failure.

24 hour mains fail battery back-up is provided using industry standard sealed lead acid batteries. Battery output for the application (2 x 12V batteries or up to 17 AH capacity) can be fitted inside the enclosure.

A relay output is provided for remote monitoring of mains fail and battery faults etc.

### Key Features

- 24V DC power supply for the detector and alarm systems with mains supply monitoring and battery monitoring and charging.
- Intelligent power supply module relays output to detector alarm system as needed.
- 100CMA @ 24V DC test output available via two reconfigurable protected outputs for improved system fault tolerance.
- EMC-A Compliant for accepted use throughout Europe, as required by most approval bodies.
- Health conscious to meet Statens range of specifiers.

### Applications

Statens detectors and power supply units have been successfully applied in thousands of applications worldwide.



### SPECIFICATIONS

Supply Voltage:	200V - 250V AC 50/60Hz
Max. Current Consumption:	0.5A @ 20V AC
Output Voltage:	27V ± 1% (main), 0V
Normal Current Supplied:	2.5A
Low Battery Threshold:	22.0V
Battery Signal Threshold:	20.4V
Operating Temperature Range:	-5 to +40C
Operating Humidity Range:	0 - 90% RH
Dimensions:	185W x 408H x 97D (mm)
Cable terminal size:	2.5mm <sup>2</sup>
Weight (without battery):	6kg

### ORDERING INFORMATION

Part No.	Description
30825	PS25 2.5Amp Power Supply Unit
30822	12V 17AH Battery (2 required)

Copyright © 2007 AirSense Technology Ltd. Stratos, R510, Micro and ClassFire are registered trademarks of AirSense Technology Ltd.

1 Canton Place - Canton Way - Stoverage - Herts - SG7 2JG - UK  
 e-mail: [sales@airsense.co.uk](mailto:sales@airsense.co.uk) [www.airsensetechnology.com](http://www.airsensetechnology.com)

1801 Wing On Central Building - 26 Des Voeux Road Central - Central Hong Kong  
 Tel: (852) 2561 4206 • Fax: (852) 3007 4737  
 e-mail: [keon.hubb@airsense.co.uk](mailto:keon.hubb@airsense.co.uk)





## Angloco Mist-Tech Fire Fighting Equipment



Mist-Tech products from Angloco provide optimum firefighting performance using the latest advances of water mist technology. High quality mist is produced by the unique designs and technology of the branches and lances and not simply by forcing high pressure water through a very small hole.

Instead Mist-Tech products use water collision technology that provides a more consistent droplet size and higher efficiency mist, without the inherent problems and risks associated with ultra-high pressure systems. More of the water turns to steam, there is less entrained air and the user has greater thermal protection.

Our range of lances and branches have now been complemented by a Chimney Lance, an Eco Mist Lance, an Angled Lance, vehicle mounted/trolley CAFS systems, along with diesel and battery versions of the VMS 2000. UK brigades and training centres have tested Angloco Mist-Tech products and have achieved fantastic results. They have since purchased the lances and branches to be added to their normal appliances.

This new range of Misting /CAFS Fire Fighting Equipment can operate as a misting system only producing high efficiency water mist or switched over to foam, if required, produces CAFS. The foam is not pre-mixed so will stay ready for use without degrading for many months and is therefore suitable for use with fully biodegradable foams. However, many have found in the majority of tests that the mist will work very well alone, even on smaller class B fires without any foam or additives being used.

### Features and benefits of the Angloco Mist-Tech branches and lances.

- High efficiency using minimum amounts of water/foam
- Reduced consequential water damage
- Mist is produced by the design and technology of the branch, not by forcing high pressure water through a very small hole
- Traditional style branch in its appearance and feel
- Operating pressure remains at a safe level
- There is a minimum of entrained air in the fluid stream, because of reduced velocity, resulting in reduced risk of spreading burning debris
- Consistent water droplet size
- Low recoil/reaction force at the branch
- Quick knock-down effect on flammable liquids
- Control of burning gases by rapid cooling
- Less blocking



## Angloco Mist-Tech Mist Jet Branch A408 & High Flow A409



The standard flow A408 and the high flow A409 branches will give 61 litres of mist and 90 litres of mist respectively at 25 bar.

Lots of uniformed micro droplets that very effectively take the heat out of a fire and keep the fire fighter cool behind a wide 11 metre stream of mist.

In tests the A408 extinguished and cooled a fully involved car fire with only 60 litres of water. It extinguished an 80 litre tray with temperatures measured at 700 plus degrees with 40 litres of water and no foam.

The branches look and feel like any other branch your crews may have now so no extra operational training is required to use them.

Follow the links on page one to see the branches and lances being used in live fire situations.

Angloco Ltd Station Road, Batley, West Yorkshire WF17 5TA T: +44 (0)1924 233896 F: +44 (0)1924 233895



## Angloco



### Technical Information

Models	: A408/A409/A406QR/A407QR
Type	: Mist-Jet
Extinguishing agent	: Water
Maximum pressure	: 40 bar
Recommended pressure	: 25 bar
Flow rate in Mist Mode	: A408 - 61 L/min & A409 90 L/min (at 25 bar)
Flow rate in Jet Mode	: A408 - 122 L/min & A409 140 L/min (at 25 bar)
Maximum discharge distance in Mist Mode	: ~11m (at 25bar)
Maximum discharge distance in Jet Mode	: ~17m (at 25bar)
Connection	: 1" BSPP
Integrated Filtration	: Yes

Pressure (bar)	5	10	15	20	25	30	35	40
	Flow (L/min)							
A408	28	36	44	52	61	72	80	89
A409	40	51	65	76	90	106	125	134

Nb/ Our products are constantly being developed and improved, therefore we reserve the right to change the technical specifications without prior notice

Angloco Ltd Station Road, Batley, West Yorkshire WF17 5TA T: +44 (0)1924 233896 F: +44 (0)1924 233895



## Lances & Accessories

Angloco Mist-Tech have developed a range of misting lances and accessories. The patented collision drop technology expels vast amounts of uniformed droplets. The cooling effect is instant and piercing lances have the ability to be knocked through walls, car bonnets etc.



### Eco Piercing Lance

The new Eco Lance is 18mm in diameter. It still produces the same amount of mist but is shorter, lighter and lower in cost. Flow rates available are 70 Lpm or 90 Lpm at 25 bar.



### QR Piercing Lance

The QR (Quick Release) Standard Lance is 18mm in diameter and fits onto the QR Mist Jet Branch. Flow rates available are 70 Lpm or 90 Lpm at 25 bar.



### Piercing Lance

The Standard length Lance is 18mm in diameter. This lance fits straight onto the side line of any appliance without modification. Flow rates available are 70 Lpm or 90 Lpm at 25 bar.



### Angled Lance

The new Angled Lance enables the Fire Fighter to attack hard to reach places such as log burners and around corners. The flow rate is 20 Lpm at 25 bar.



### Chimney Lance

The Chimney Lance can be used with standard chimney rods and has a 10 metre hose and a QR coupling. It can connect onto the QR Mist Jet Branch or directly onto the side line. The flow rate is 70 Lpm at 25 bar.

Angloco Ltd Station Road, Batley, West Yorkshire WF17 5TA T: +44 (0)1924 233895 F: +44 (0)1924 233895



## Angloco Mist-Tech Mist Jet Branch Quick Release (QR) A406 and A407

The new range of Quick Release mist tech branches have a removable end which allows you to swap between the misting branch, a misting lance or a chimney lance.

They have an option of a standard 61 Lpm or high flow 140 Lpm (at 25 bar)

All our branches and lances can be fitted direct to a standard appliance without the need of any modification. The branches look and feel like a standard branch.

### To use:



Undo the simple coupling on the branch



Twist the branch head off and remove



Swap it for the misting lance - B103 or B105 H/flow



Or swap it for the chimney lance - B301

...Same branch 3 different uses...

Angloco Ltd Station Road, Batley, West Yorkshire WF17 5TA T: +44 (0)1924 233896 F: +44 (0)1924 233895



## Vehicle Mounted Misting System Technical Information VMS 2000P, VMS 2000D, VMS 2000B.

	VMS 2000P	VMS 2000D	VMS 2000B
<b>Engine:</b>	Honda – Petrol	Lombardini – Diesel	12v inverter 230v AC electric motor
<b>Start:</b>	Electrical start and manual pull cord	Electrical start and manual pull cord	Key Switch
<b>Pump:</b>	Diaphragm pump	Diaphragm pump	Diaphragm pump
<b>Working pressure:</b>	20 bar	20 bar	15 bar
<b>Extinguishing agent:</b>	Water or Foam	Water or Foam	Water or Foam
<b>Foam dosing:</b>	1 to 6%	1 to 6%	1 to 6%
<b>Flow in Mist Mode:</b>	~59l/min (20 bar)	~59l/min (20 bar)	~22l/min (15 bar)
<b>Flow in Jet Mode:</b>	~112l/min (20 bar)	~112l/min (20 bar)	~65l/min (15 bar)
<b>Droplet size:</b>	50-150 microns	50-150 microns	50-150 microns
<b>Maximum discharge distance:</b>	~10m (~20m Jet Mode)	~10m (~20m Jet Mode)	~10m (~12m on Jet Mode)
<b>Hose reel:</b>	Manual with rollers guide	Manual with rollers guide	Manual with rollers guide
<b>Hose lengths:</b>	30m or 60m	30m or 60m	30m or 60m
<b>Hose size:</b>	3/4" Ultra Light Hose	3/4" Ultra Light Hose	3/4" Ultra Light Hose
<b>Working temperature:</b>	-5°C / +60°C	-5°C / +60°C	-5°C / +60°C
<b>Storage temperature:</b>	-5°C / +60°C	-5°C / +60°C	-5°C / +60°C

Angloco Ltd Station Road, Bailey, West Yorkshire WF17 5TA T: +44 (0)1924 23886 F: +44 (0)1924 23885



## A range of tips are available to add to the lances.



**Attack Standard Flow**  
The Attack tip has a flow rate of 70 Lpm at 25 bar.



**Attack High Flow**  
The High Flow tip has a flow rate of 90 Lpm at 25 bar.



**Water Wall**  
The water wall tip has a flow rate of 100 Lpm at 25 bar and gives the Fire Fighter more protection.



**Piercing Hammer**  
The piercing hammer has a sharpened head to assist with creating a hole and a flat surface for driving the lance through the material. The piercing hammer comes with a hand strap.

Angloco Ltd Station Road, Bailey, West Yorkshire WF17 5TA T: +44 (0)1924 23886 F: +44 (0)1924 23885

## Main advantages of high efficiency Water Mist:

- Rapid extinguishing
  - Water saving
- Safe for use on or around humans & animals
  - Safe on electrical fires
- Minimal collateral damage / no flooding risk
  - Superior cooling
  - No thermal shock
- Safe for the user due to mist barrier between fire and operator
  - Environmental friendly

NB/ Our products are constantly being developed and improved, therefore we reserve the right to change the technical specifications without prior notice.



Angloco Ltd  
Station Road  
Batley  
West Yorkshire  
WF17 5TA

T: 01924 233886  
E: [rachel.morris@angloco.co.uk](mailto:rachel.morris@angloco.co.uk)  
W: [www.angloco.co.uk](http://www.angloco.co.uk)

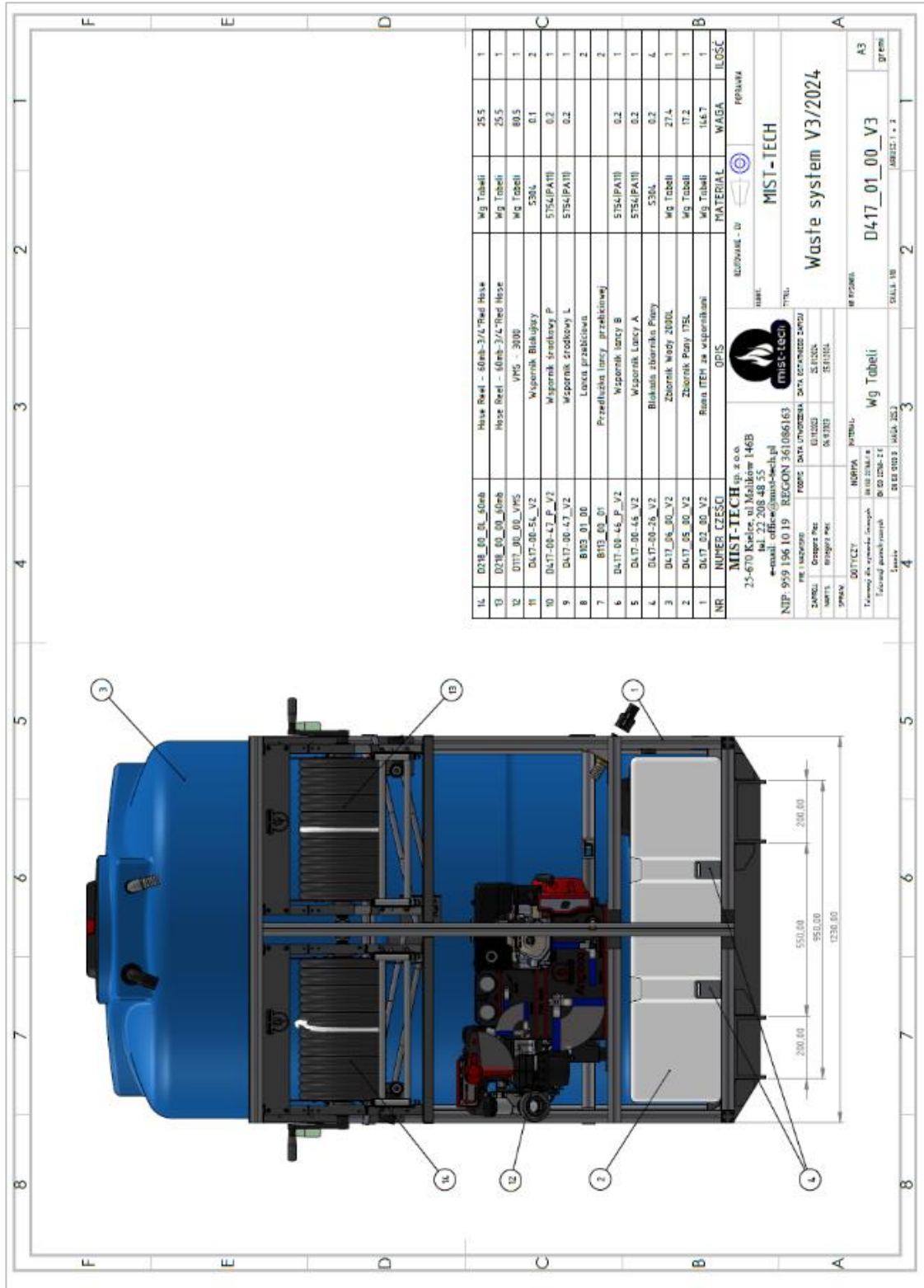

IL	DZIM_00_00_00mk	Hose Reel - 60mb-3/4"Red Hose	Wg Tabelli	25.5	1
13	DZIM_00_00_00mk	Hose Reel - 60mb-3/4"Red Hose	Wg Tabelli	25.5	1
12	DZIM_00_00_VMS	VMS - 3000	Wg Tabelli	80.5	1
11	D417-00-5C_V2	Wspornik Białogłazy	530L	0.1	2
10	D417-00-4T_P_V2	Wspornik trójkątny P	5754(PA1H)	0.2	1
9	D417-00-4T_V2	Wspornik trójkątny L	5754(PA1H)	0.2	1
8	B103_01_00	Lecna przeciwbicia			2
7	B103_00_01	Przeciwna lancy przeciwbicia			2
6	D417-00-4S_P_V2	Wspornik lancy B	5754(PA1H)	0.2	1
5	D417-00-4S_V2	Wspornik lancy A	5754(PA1H)	0.2	1
4	D417-00-7S_V2	Blokada zbiornika Płyty	530L	0.2	4
3	D417_04_00_V2	Zbiornik wody 2000L	Wg Tabelli	27.4	1
2	D417_05_00_V2	Zbiornik Płyty 175L	Wg Tabelli	17.2	1
1	D417_02_00_V2	Płyna TET za wspornikami	Wg Tabelli	16.7	1
NR	NUMER CZĘŚCI	OPIS	MATERIAL	WAGA	ILOSC



**MIST-TECH** sp. z o.o.  
 25-670 Kielce, ul. Małkowska 146B  
 tel. 22 208 48 55  
 e-mail: office@mist-tech.pl

NIP: 959 196 10 19 REGON: 361086163  
 KOD MIASTA: 25-1000  
 KOD KRAJU: PL  
 KOD GOSPODARSTWA: 251000  
 KOD WYDZIAŁU: 251000

**MIST-TECH**  
 Waste system V3/2024

NR FORMY: D417\_01\_00\_V3  
 SKALA: 1:1  
 ARKUSZ: 1 z 2  
 gram

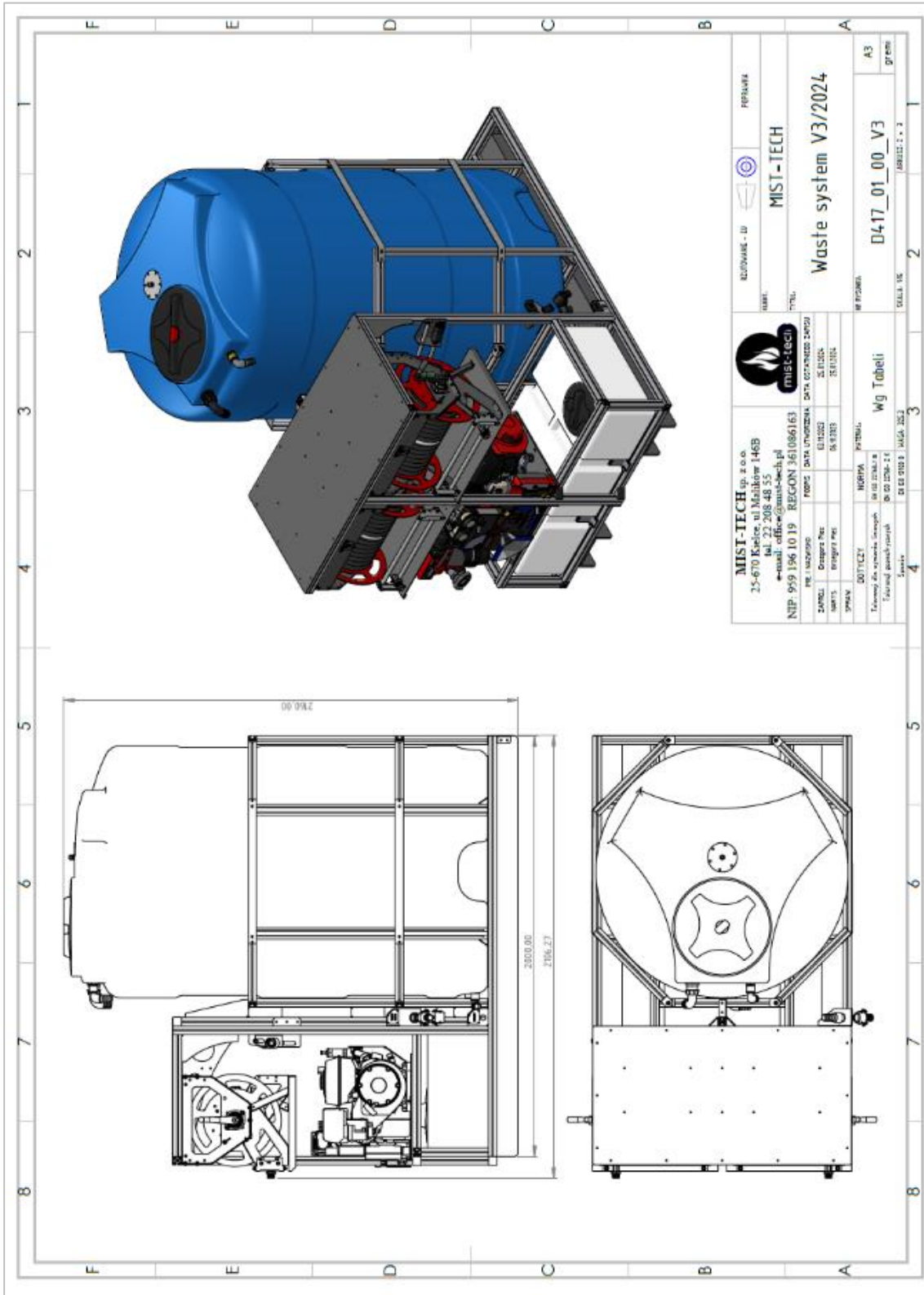

<b>MIST-TECH</b> sp. z o.o. 25-670 Kalesie, ul. Malbork 146B tel. 22 208 48 35 e-mail: office@mist-tech.pl NIP: 959 196 10 19 REGON 361086163		<b>PROJEKT</b> DATA UTYWIKOWA DATA OCHRONNEJ ZAPASY		<b>PROJEKTANT</b>	
ZAPLECZKO	Drugała Pas	UL.12022	25.11.2024	MIST-TECH	
WARTY	Strzegom Pas	05.9.2023	25.11.2024	Waste system V3/2024	
OPRACOWANIE	DOTYK27	NADZORCA		MIST-TECH	
Terminy dla wykonawcy (miesiące)		01.03.2024-31.03.2024		Wg Tabeli	
Terminy dla nadzorców (miesiące)		01.03.2024-31.03.2024		D417_01_00_V3	
Jawiszka		01.03.2024 - 31.03.2024		A3	
				DZIENNIK	

Appendix 7



**albarrie**  
Compliance Services  
Compliance : Capability : Certainty : Confidence

## PORTABLE APPLIANCE TEST REPORT

---

For H W Martin Ltd

HW Martin Waste Recycle Ltd  
DRC  
Wath West  
Rotherham  
S63 6EX

Report Date: 21/02/2024

Section 1: Testing Summary  
Section 2: All Appliances

Please visit our website to view a full range of our services at [www.calbarria.com](http://www.calbarria.com).

© 2024 Total Compliance Software (TCS) Ltd. All rights reserved. Printed on 21/02/2024

CALUMMASANU | REFERENCE

## PORTABLE APPLIANCE TEST REPORT: TESTING SUMMARY

---

**DATE: 21/02/2024**

Page 1 of 1

Created by Total Compliance Software

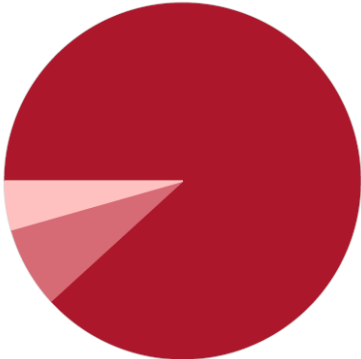

Full Tests: 60  
Visual Tests: 5  
M/E Tests: 3

Fuses Replaced	0
Plug Tops Replaced	0
Repaired	0
Failed	0







# Legato® Interlocking Concrete Blocks

Elite are proud to present the ultimate interlocking block - Legato®, the name coming from the Italian for 'tied together'.

Elite are the only company in Europe to manufacture interlocking blocks using high strength (50N/mm<sup>2</sup>) concrete. This allows our Legato® blocks to exhibit extreme levels of durability, combined with the flexibility of having their own cast-in lifting pin. As each standard block will build 1.28m<sup>2</sup> of wall, they provide an incredibly quick solution in a wide variety of applications.

These include...

- Support walls for roof structures**
- Cofferdams**
- Bay walls**  
for materials such as...
  - Aggregates
  - Salt
  - Light scrap metals
  - Wood chip
  - Tyres
  - White goods
  - RDF waste
  - Black bag waste
  - Bales etc...
- Push Walls**
- Grain storage**
- Earth retention Etc etc...**

In addition, because the blocks do not contain anything other than high quality, locally sourced aggregates and Portland Cement, you can be assured that your investment will last a lifetime.

See reverse for the full range and specifications.



CLASS  
A1 FIRE  
RESISTANT

Class A1 fire resistant in accordance with clause 4.3.4.4 of EN13369.

**Please note:** The concrete finish of our interlocking blocks is classed as 'Basic' in accordance with the 4th Edition of the National Structural Concrete Specification for Building Construction. <https://formworkdokuuk.com/2019/08/12/a-guide-to-visual-and-architectural-concrete-finishes/>. I.e. there are no requirements other than the concrete being adequately compacted to achieve the density and compressive strength required. The Legato blocks have a moulded face and a trowelled face - where appearance might be of concern, the moulded face tends to offer a smoother and more consistent look. Please note that blocks can be easily damaged if impact occurs during construction and Elite cannot be held responsible for damage caused after the blocks have been delivered and signed for by the client.

Traveling quickly and/or traveling over rough terrain when carrying blocks or barriers should be avoided as excessive sudden jerking movements could damage the product.

For more information on Elite quality concrete products  
phone 01952 588 885 or browse [www.eliteprecast.co.uk](http://www.eliteprecast.co.uk)

# Legato® Interlocking Concrete Blocks

## Legato® interlocking block range

Our Legato® blocks come in various sizes - including flat top versions - the standard block is an **LG8 1600mm x 800mm x 800mm** (highlighted in the table opposite) and weighs in at 2400 kgs.

As each Legato® block has its own lifting pin cast into it - you can easily change the way in which they are configured without the need for specialist lifting equipment or grabs.

Durability, strength and availability are the key features of these blocks and a next-day nationwide service means that you are never more than 24 hours away from taking delivery.

**Important note:** Prior to lifting older / pre-used blocks check the lifting pin for wear / corrosion and check the block for cracks. If the block is cracked or the pin is worn it could fail when being lifted.

**Additional Notes:** Wind loading can affect the stability of single skin, stand-alone Legato block walls above 4.8m high. If in doubt get it checked by a qualified structural engineer. Direct Impact between mobile plant and the block walls is unnecessary and should be avoided as in extreme cases this could dislodge blocks from the wall. If you identify a particular risk then strapping the top layers can help to mitigate the risk.

Legato® Block Code	L x W x H mm	Weight
LG1	400 x 800 x 800	590kg
LG2	400 x 800 x 800	600kg
LG3	800 x 800 x 800	1180kg
LG4	800 x 800 x 800	1200kg
LG5	1200 x 800 x 800	1775kg
LG6	1200 x 800 x 800	1800kg
LG7	1600 x 800 x 800	2365kg
<b>LG8</b>	<b>1600 x 800 x 800</b>	<b>2400kg</b>
LG9	1600 x 800 x 800	1765kg
LG10	1600 x 800 x 800	1800kg
LG11 (Spreader)	1600 x 800 x 800	1800kg
LG12 (Bend)	1590 x 800 x 800	2240kg
LG12F (Bend)	1590 x 800 x 800	2240kg
LG14 (Capping)	1600 x 800 x 800	2065kg
LG Wedge	800 x 800 x 800	590kg

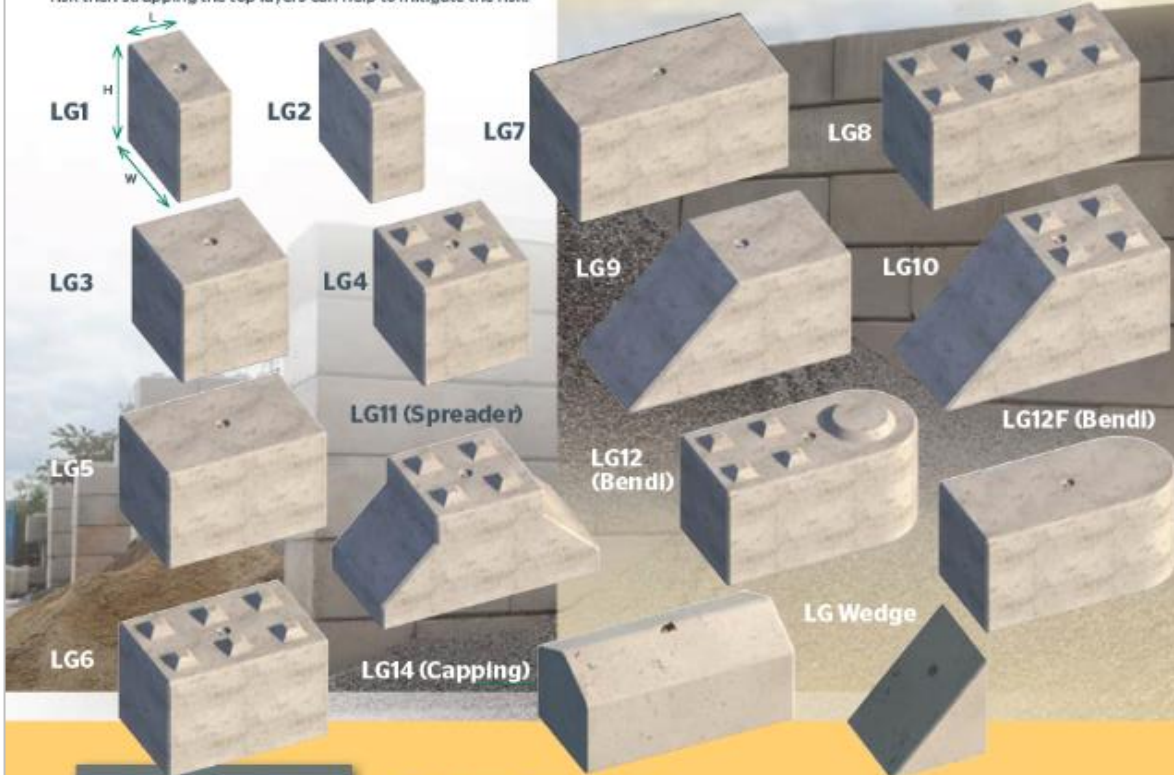

**ELITE**  
PRECAST CONCRETE

Elite Precast Concrete Limited  
Halesfield 9, Telford, Shropshire TF7 4QW  
Tel: 01952 588885 Fax: 01952 582011  
[www.eliteprecast.co.uk](http://www.eliteprecast.co.uk)

**Important note:**  
It is the customer's responsibility to ensure appropriate structural checks are carried out before any precast concrete products are installed.