

Waste4Generation Ltd Corby Facility Final effluent odour Process

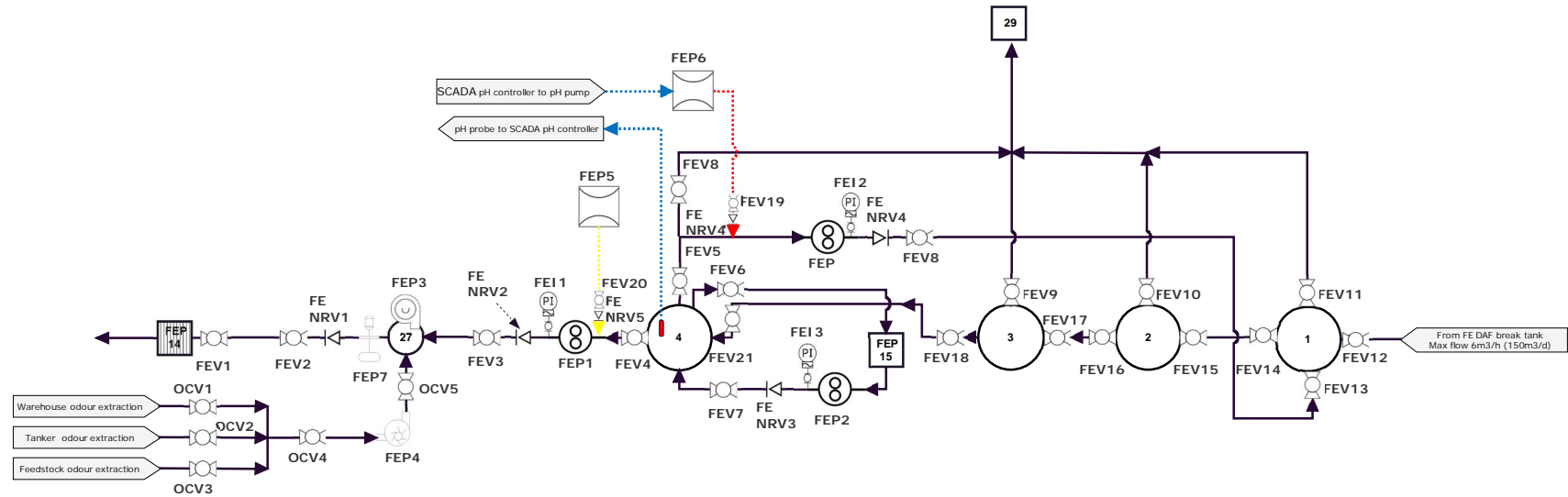

FE Plant & Equipment			
FE Plant no	Description	Specification	Comments
FEP1	Final effluent pump	10m3/hr Roto pump	Supplier Roto Pumps
FEP2	Nano bubble pump	TBD	
FEP3	Methane scrubber blower		
FEP4	Odour extraction blower		
FEP5	Peroxide dosing pump	Watson&Marlow peristaltic pump	Supplier Watson & Marlow
FEP6	pH dosing pump	Watson&Marlow peristaltic pump	Supplier Watson & Marlow
FEP7	Odour scrubber submersible pump	20m3/hr	Supplier whisper pumps
FEI1	FE pump pressure instrument	0-10 bar 40-20MA	Supplier RS Components
FEI2	Nano unit pump pressure instrument	0-10 bar 40-20MA	Supplier RS Components
FEI3	Nano re-circulation pump pressure instrument	0-10 bar 40-20MA	Supplier RS Components
FEP14	Ceramic filter	6m3/hr	Supplier OXYFUSION
FEP15	Nano bubble unit		Supplier OXYFUSION
FEP16	Nano bubble re-circulation pump		

Tank Capacities			
Item no	Description	Specification	Comments
1	Polishing tank A	10 m3	
2	Polishing tank B	7 m3	
3	Polishing tank C	7 m3	
4	FE / Nano bubble Ozone unit	10 m3	
27	Odour scrubber	1m3	
29	Onsite pumping station	1m3	

Valve Schedule			
Valve no	Description	Specification	Comments
FEV1	Ceramic filter valve	TBD	
FEV2	Submersible pump valve		
FEV3	Odour scrubber valve		
FEV4	Nano bubble outlet valve		
FEV5	Nano bubble re-circulation valve		
FEV6	Nano bubble unit feed valve		
FEV7	Nano bubble tank inlet valve		
FEV8	Re-circulation pump valve		
FEV9	Polishing tank C sludge valve		
FEV10	Polishing tank B sludge valve		
FEV11	Polishing tank A sludge valve		
FEV12	FE DAF inlet valve		
FEV13	Nano re-circulation inlet valve		
FE14	Polishing tank A outlet valve		
FE15	Polishing tank B inlet valve		
FE16	Polishing tank B outlet valve		
FE17	Polishing tank C inlet valve		
FE18	Polishing tank C outlet valve		
FE19	Caustic isolation valve		
FE20	Peroxide isolation valve		
FEV21	Nano bubble tank inlet valve		
FENRV1	Submersible pump NRV		
FENRV2	Final Effluent pump NRV		
FENRV3	Nano bubble pump NRV		
FENRV4	Re-circulation pump NRV		
OCV1	Odour control valve 1	Warehouse odour extraction	
OCV2	Odour control valve 2	Tanker odour extraction	
OCV3	Odour control valve 3	Feedstock odour extraction	
OCV4	Odour control valve 4	Odour extraction blower	