

Operating hours
xx h/d => XXXX h/y
yy d/w => YYY d/y

Operating hours
24 h/d => 8 760 h/y
7 d/w => 365 d/y

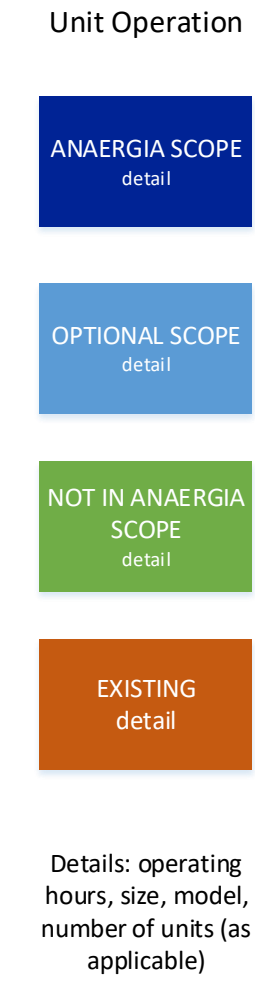

Site constructed tank
(bolted steel or concrete)

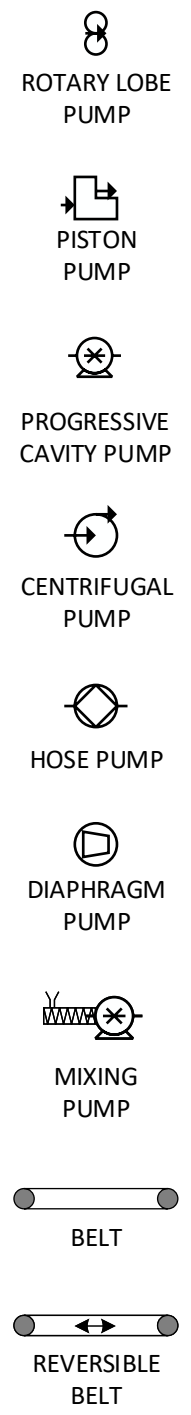
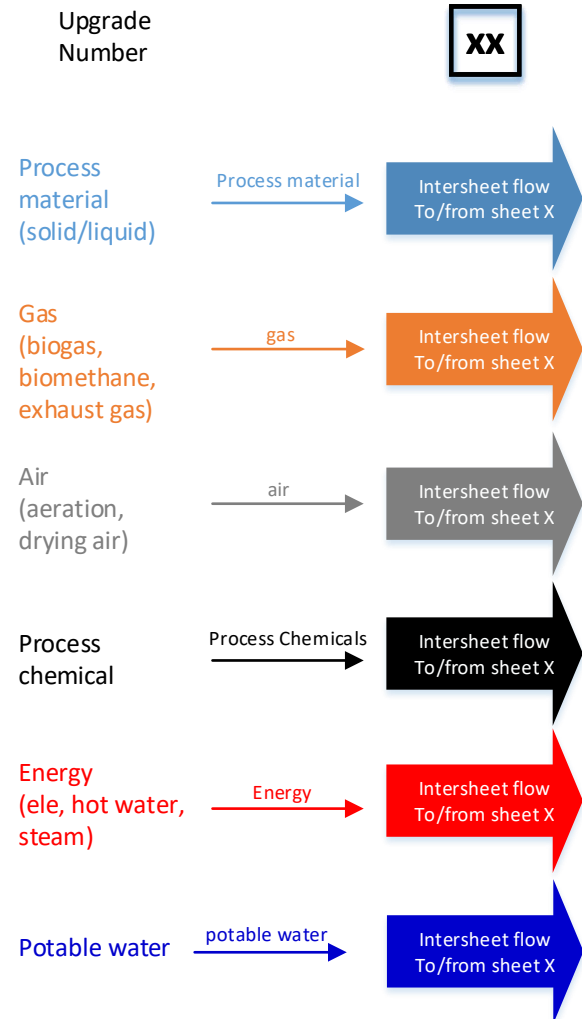
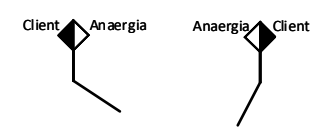
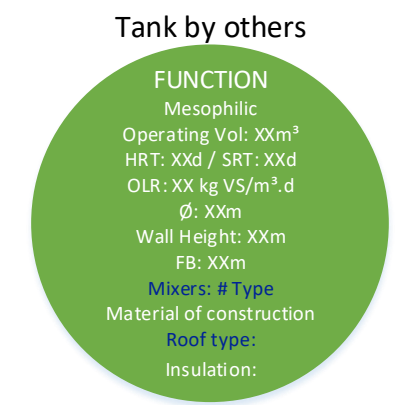
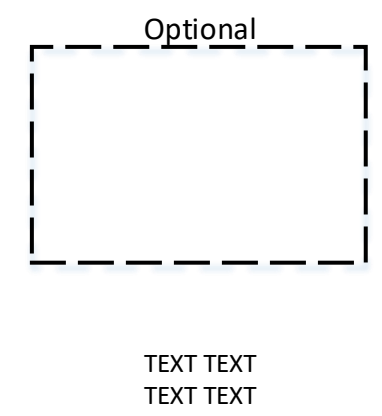
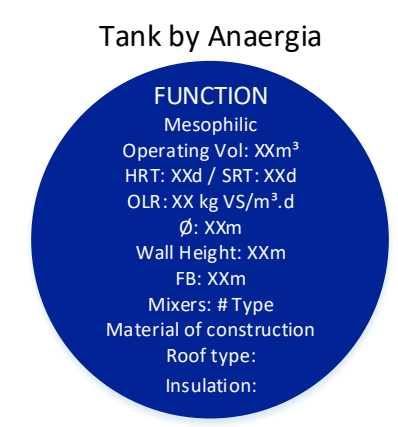

Text in blue is the equipment provided by Anaergia

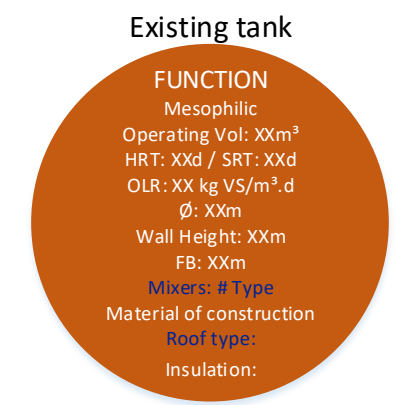

Prefabricated tank (HDPE or Stainless steel)



Comments:
1 ...
2 ...
3 ...

| Rev. | Date | Creat. | Check. | Appr. | Comments |
|------|------|--------|--------|-------|----------|
| | | | | | |
| | | | | | |
| | | | | | |
| | | | | | |
| | | | | | |
| | | | | | |
| | | | | | |
| | | | | | |
| | | | | | |
| | | | | | |

| | |
|--|--|
| Drawing Name: | |
| Project: | |
| Project-No: | |
| Country: | |
| Customer: | |
| <p>The entire content of this drawing and any related documents are and shall remain the intellectual property of Anaergia, Inc., and shall not be used except as authorized, unless written consent has been granted by the said company. Users may not copy, re-transmit or download, for any commercial or noncommercial purpose, this drawing or any part thereof. The figures shown in this Block Flow Diagram represent the Basis of Design and are not guaranteed values, refer to contract for process guarantee values.</p> | |

Reception Hall

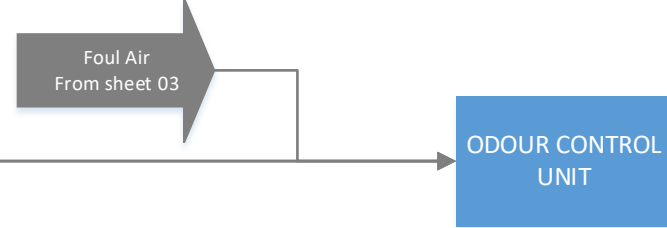
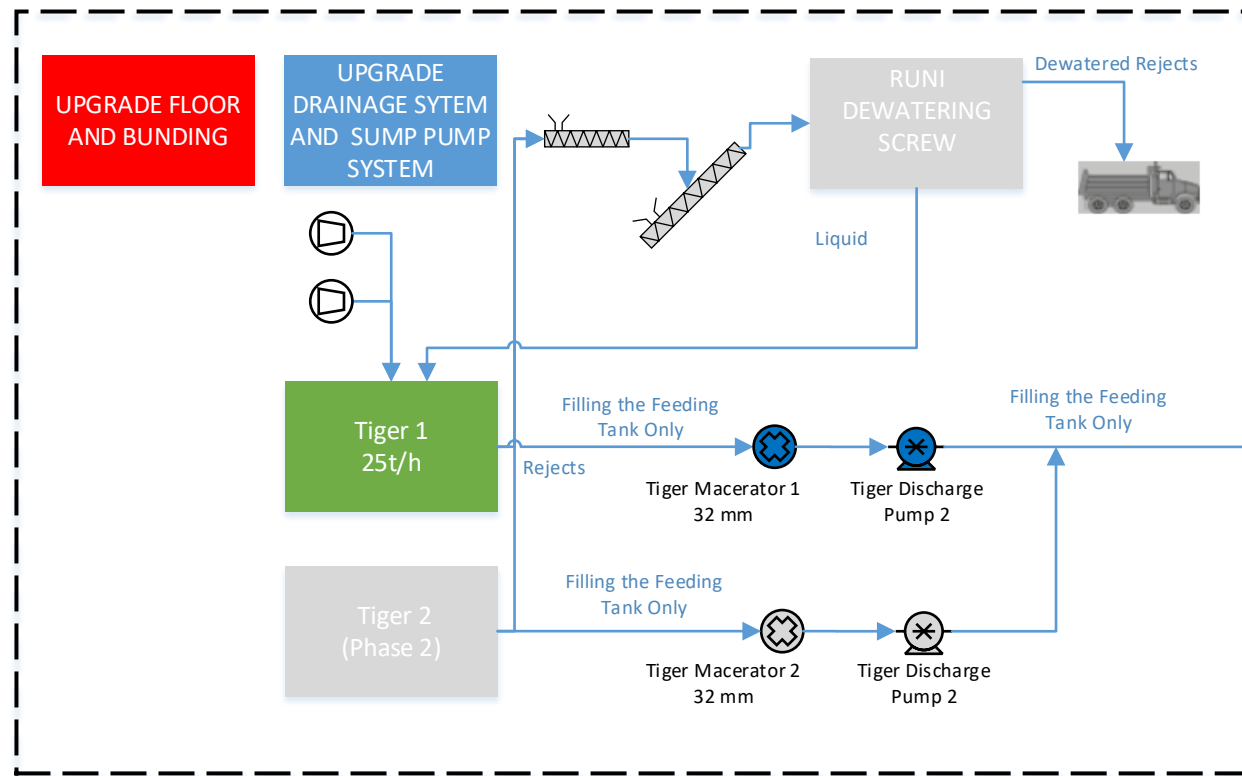

- Equipment List Prices for Tuesday 20th**
- 32 mm Reception Hall Rotacut RCQ43G (bypassable)
 - Reception Hall Netzsch NM105
 - Dilution pump starter for tiger dilution
 - 12 mm ABP Rotacut RCX-58 x2 duty standby
 - Pasteuriser Filling Netzsch NM105 x2 VFD control
 - Pasteuriser Emptying Netzsch NM105
 - Pasteuriser Recirc Mixing Pump
 - Plus Other Pasteuriser Motors

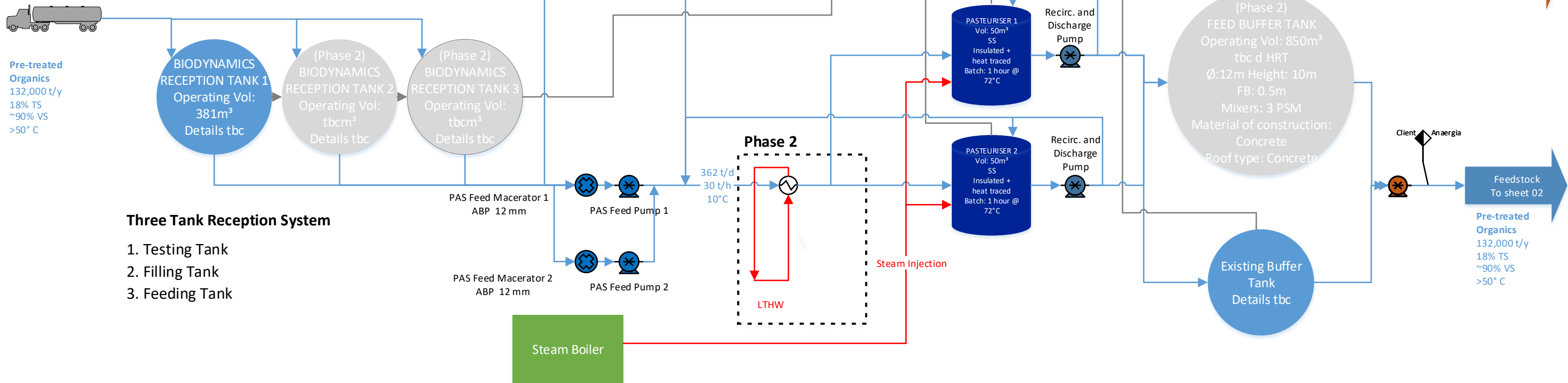

Three Tank Reception System

1. Testing Tank
2. Filling Tank
3. Feeding Tank

Comments:

- 1 ...
- 2 ...
- 3 ...

| Rev. | Date | Creat. | Check. | Appr. | Comments |
|-------|------------|--------|--------|-------|----------|
| Rev 1 | 09/07/2021 | BJP | | | |
| Rev 0 | 11/03/2021 | BJP | | | |

Drawing Name: Additional Items Sheet 01

Project: Bio Dynamic, Nottingham

Project-No:

Country: UK

Customer: BioDynamic



The entire content of this drawing and any related documents are and shall remain the intellectual property of Anaergia, Inc., and shall not be used except as authorized, unless written consent has been granted by the said company. Users may not copy, re-transmit or download, for any commercial or noncommercial purpose, this drawing or any part thereof. The figures shown in this Block Flow Diagram represent the Basis of Design and are not guaranteed values, refer to contract for process guarantee values.

365 d/y
24 h/d
=> 8 760 h/y

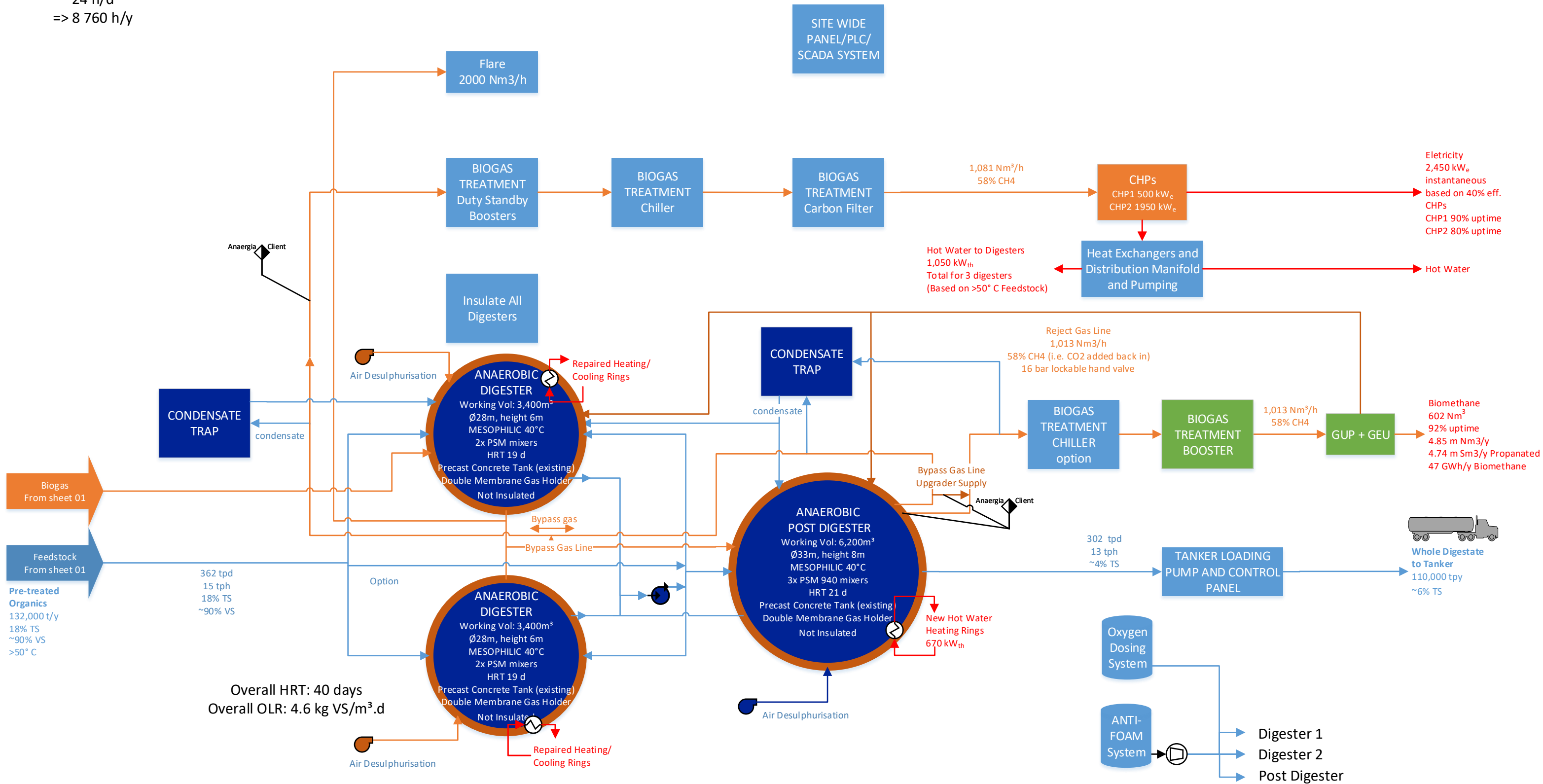

Comments:

1 ...

2 ...

3 ...

| Rev. | Date | Creat. | Check. | Appr. | Comments |
|-------|------------|--------|--------|-------|----------|
| Rev 1 | 09/07/2021 | BJP | | | |
| Rev 0 | 11/03/2021 | BJP | | | |

Drawing Name: Additional Items Sheet 02
Project: Bio Dynamic, Nottingham
Project-No:
Country: UK
Customer: BioDynamic



The entire content of this drawing and any related documents are and shall remain the intellectual property of Anaergia, Inc., and shall not be used except as authorized, unless written consent has been granted by the said company. Users may not copy, re-transmit or download, for any commercial or noncommercial purpose, this drawing or any part thereof. The figures shown in this Block Flow Diagram represent the Basis of Design and are not guaranteed values, refer to contract for process guarantee values.

365 d/y
24 h/d
=> 8 760 h/y

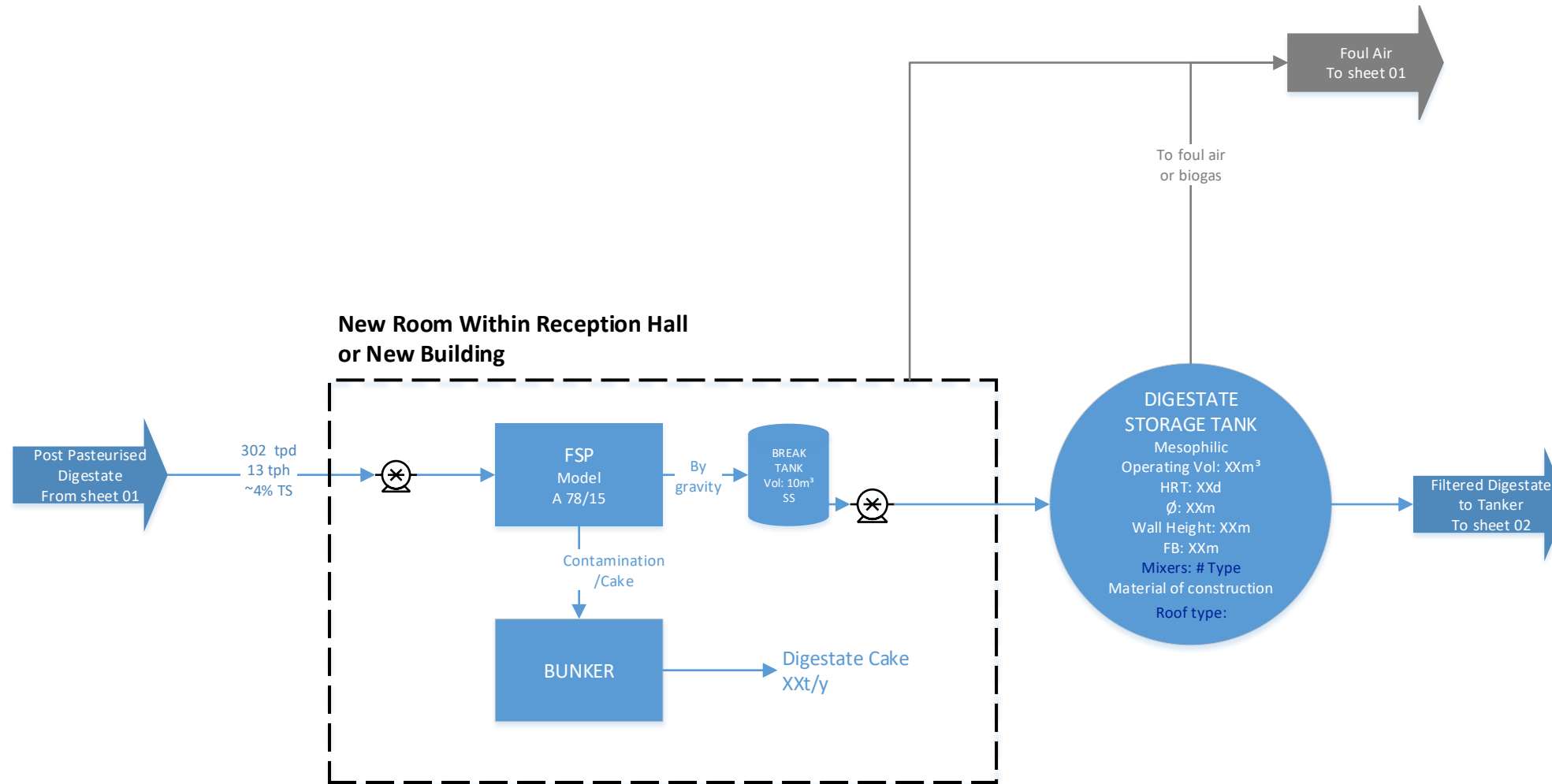

Comments:

- 1 ...
- 2 ...
- 3 ...

| Rev. | Date | Creat. | Check. | Appr. | Comments |
|-------|------------|--------|--------|-------|----------|
| Rev 0 | 11/03/2021 | BJP | | | |
| | | | | | |
| | | | | | |
| | | | | | |
| | | | | | |

Drawing Name: Additional Items Sheet 03
Project: Bio Dynamic, Nottingham
Project-No:
Country: UK
Customer: BioDynamic



The entire content of this drawing and any related documents are and shall remain the intellectual property of Anaergia, Inc., and shall not be used except as authorized, unless written consent has been granted by the said company. Users may not copy, re-transmit or download, for any commercial or noncommercial purpose, this drawing or any part thereof. The figures shown in this Block Flow Diagram represent the Basis of Design and are not guaranteed values, refer to contract for process guarantee values.