

ITEM NO.	PART NUMBER	DESCRIPTION	QTY.
1	1049-500-032		1
2	1020-300-007B	1200 Wide Conveyor Drive Drum	1
3	5000-110-001	Square Flange Unit FYH UCF 313 65mm Bore	2
4	5000-510-003	5.5kW 24RPM 50mm Bore (Conveyor Drive 24)	1
5	1020-300-A03A	1200 Wide Tail Drum Asm	1
6	5000-120-001	Normal Duty Pillow Block 55mm Bore	2
7	1020-400-017	1000 Wide Return Roller	5
8	1020-400-003	1200 Wide Load Roller	6
ITEM NO.	SW-File Name (File Name)	DESCRIPTION	QTY.
9	5000-300-012	Belt Scraper 100mm Long	12
ITEM NO.	PART NUMBER	DESCRIPTION	Default/QTY.
10	1049-500-060	1200 Wide Return Scaper Blade	1

M&K Quarry Plant Ltd - M&K Recycling Solutions Ltd 55 Cappagh Road, Galbally, Dungannon Co Tyrone, N Ireland, BT70 2PE t - +(0)44 28 8775 8396 f - +(0)44 28 8775 8557			UNLESS OTHERWISE SPECIFIED: DIMENSIONS ARE IN MILLIMETERS TOLERANCES: 0 - ±1.0mm 0.0 - ±0.25mm 0.00 - ±0.05mm ANGLES - ±0.5°	NOTES: 1. ALL DIMENSIONS SUBJECT TO MODIFICATION ON COMPLETION OF DETAILED DESIGNS 2. ALL CIVILS WORKS TO BE CARRIED OUT BY CUSTOMER FOUNDATION LOADINGS ON REQUEST FROM THE MK GROUP 3. RECOMMENDED MAGNET LOCATION IS AFTER THE PICKING STATION. OTHER POSITIONS WILL POTENTIALLY CAUSE JAMMINGPOINTS. IF MAGNET MUST BE FITTED OTHER THAN ABOVE THEN CORRECT PRE-SORTING OF MATERIAL IS ESSENTIAL.	DEBUR AND BREAK SHARP EDGES	DO NOT SCALE DRAWING THRID ANGLE PROJECTION
REVISION				TITLE:		
M&K Quarry Plant Ltd - M&K Recycling Solutions Ltd THIS DRAWING AND DESIGN IS THE PROPERTY OF M&K QUARRY PLANT Ltd - M&K RECYCLING SOLUTIONS Ltd. IT MUST NOT BE COPIED OR SUBMITTED TO A THIRD PARTY WITHOUT THE WRITTEN CONSENT OF M&K QUARRY PLANT Ltd - M&K RECYCLING SOLUTIONS Ltd.				DWG NO. 1049 TPS GA REV G		
MATERIAL:				A3		
WEIGHT:				SCALE: NTS SHEET 1 OF 1		

REV 'A'	REV 'B'	REV 'C'	REV 'D'	REV 'E'
---------	---------	---------	---------	---------

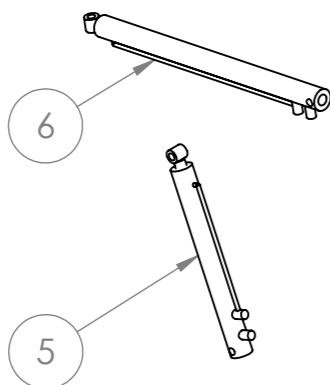
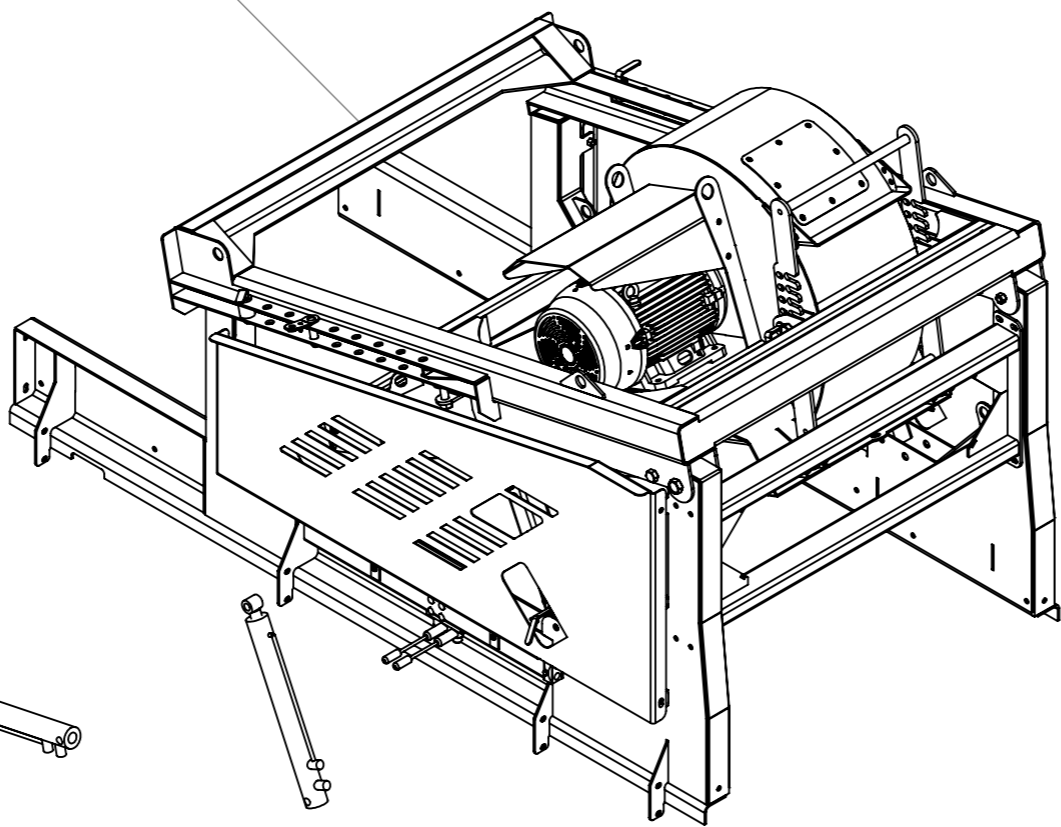
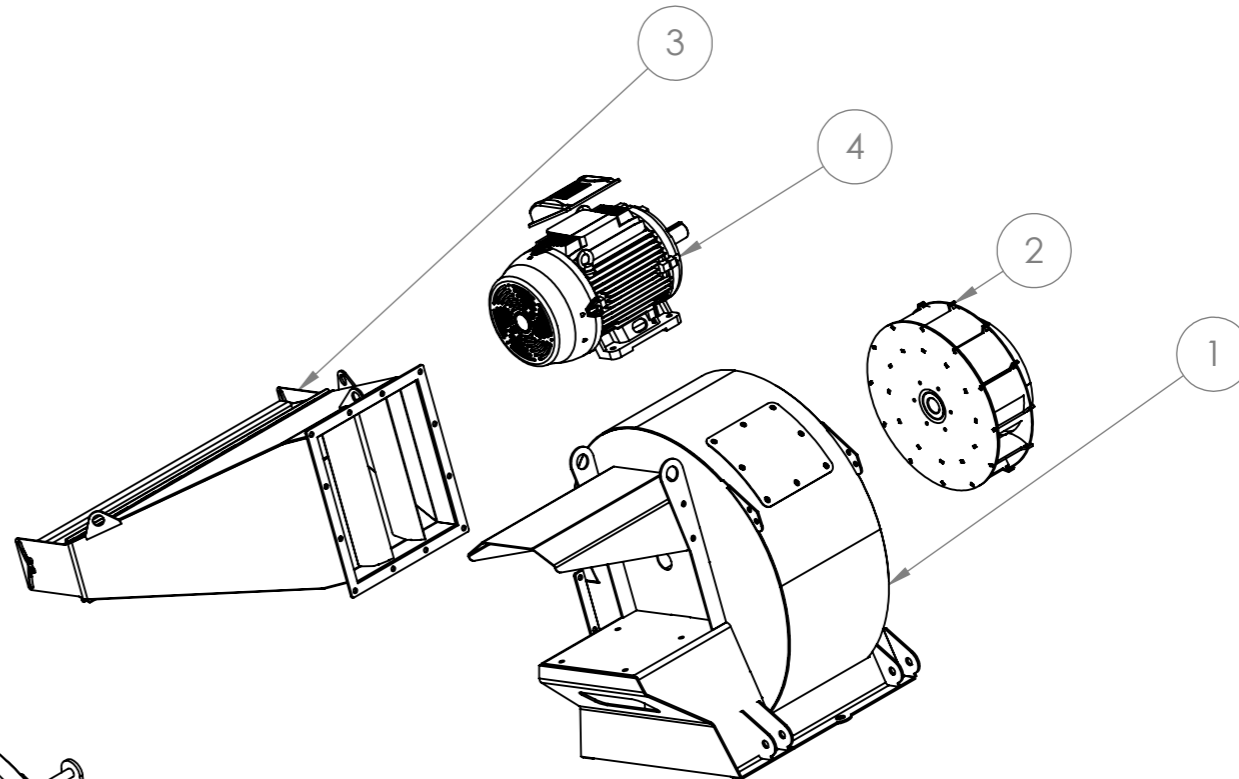
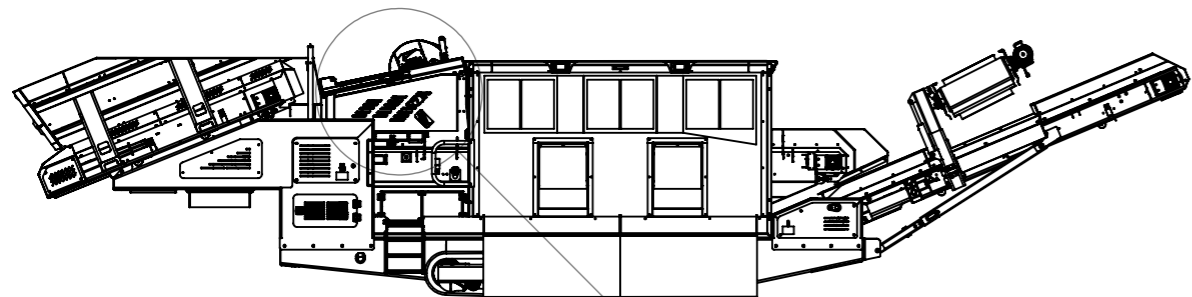

ITEM NO.	PART NUMBER	DESCRIPTION	QTY.
1	1049-400-A03A	Blower Frame	1
2	1080-200-A01		1
3	1049-400-A23		1
4	5000-511-008	15KW 2Pole 160 Frame B3	1
ITEM NO.	PART NUMBER	DESCRIPTION	QTY.
5	5000-410-004	50 Bore 500 Stroke Ram	2
6	5000-410-003	50mm Bore 600mm Stroke	1

M&K Quarry Plant Ltd - M&K Recycling Solutions Ltd
 55 Cappagh Road, Galbally, Dungannon Co Tyrone, N Ireland, BT70 2PE
 t - +(0)44 28 8775 8396
 f - +(0)44 28 8775 8557

UNLESS OTHERWISE SPECIFIED: DIMENSIONS ARE IN MILLIMETERS TOLERANCES:
 0 - ±1.0mm
 0.0 - ±0.25mm
 0.00 - ±0.05mm
 ANGLES - ±0.5°

NOTES:
 1. ALL DIMENSIONS SUBJECT TO MODIFICATION ON COMPLETION OF DETAILED DESIGNS
 2. ALL CIVILS WORKS TO BE CARRIED OUT BY CUSTOMER FOUNDATION LOADINGS ON REQUEST FROM THE MK GROUP
 3. RECOMMENDED MAGNET LOCATION IS AFTER THE PICKING STATION. OTHER POSITIONS WILL POTENTIALLY CAUSE JAMMINGPOINTS. IF MAGNET MUST BE FITTED OTHER THAN ABOVE THEN CORRECT PRE-SORTING OF MATERIAL IS ESSENTIAL.

DEBUR AND BREAK SHARP EDGES

DO NOT SCALE DRAWING THRID ANGLE PROJECTION

REVISION

REV 'A'	REV 'B'	REV 'C'	REV 'D'	REV 'E'

NAME	SIGNATURE	DATE
DRAWN		12/03/2020
CHK'D		
APPV'D		
MFG		
Q.A		

M&K Quarry Plant Ltd - M&K Recycling Solutions Ltd
 THIS DRAWING AND DESIGN IS THE PROPERTY OF M&K QUARRY PLANT Ltd - M&K RECYCLING SOLUTIONS Ltd. IT MUST NOT BE COPIED OR SUBMITTED TO A THIRD PARTY WITHOUT THE WRITTEN CONSENT OF M&K QUARRY PLANT Ltd - M&K RECYCLING SOLUTIONS Ltd.

TITLE:	
DWG NO.	1049 TPS GA REV G
A3	

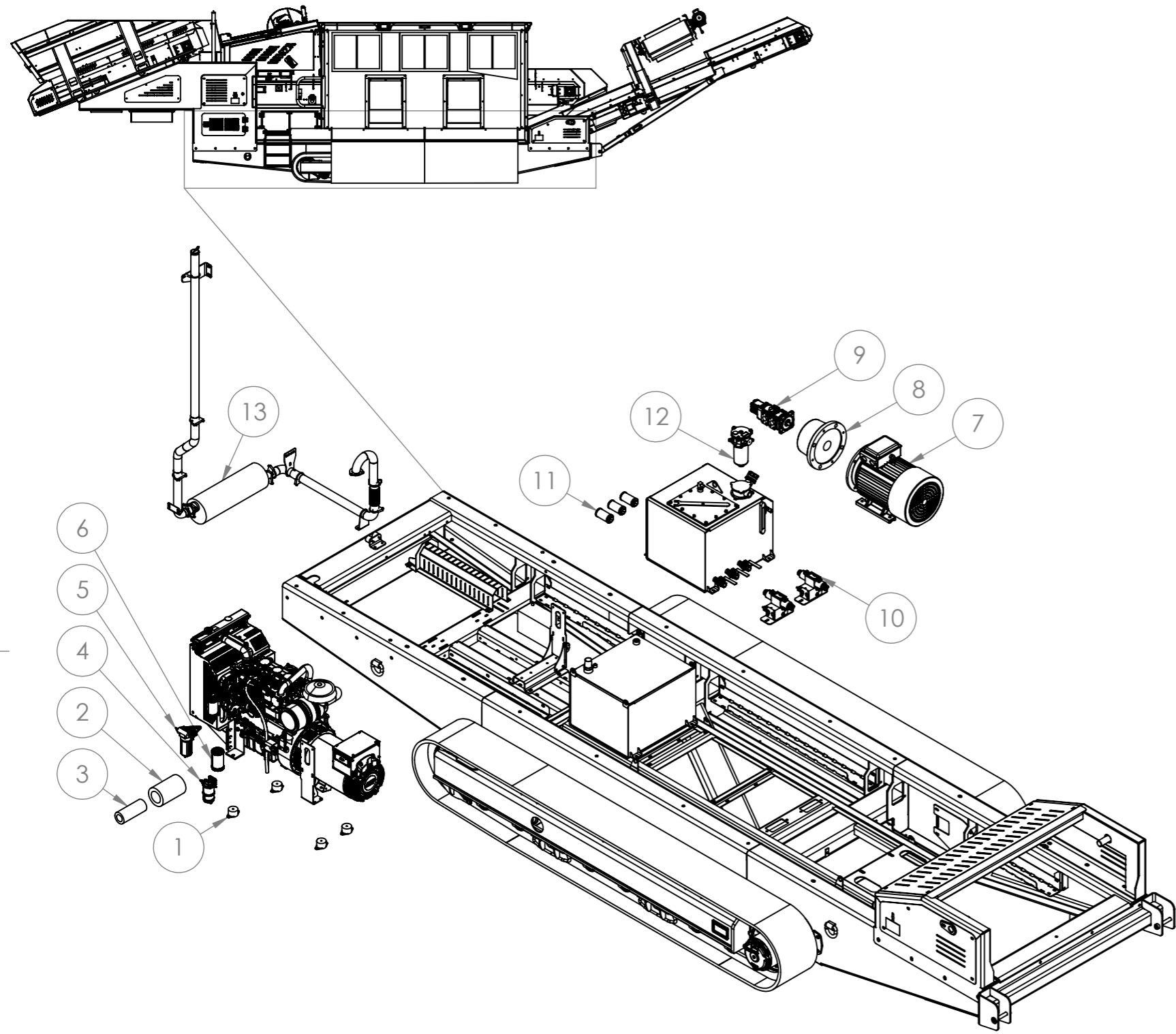

ITEM NO.	PART NUMBER	DESCRIPTION	QTY.
1	5000-370-013	FCM21 Flanged Circular Mount M12 Female	4
2	5000-730-005	26510342 Air Filter Element (outer)	1
3	5000-730-006	26510343 Air Filter Element (inner)	1
4	5000-730-007	130306360 Element Fuel - Pre Fuel	1
5	5000-730-008	4816636 Fuel Filter	1
6	5000-730-009	2654407 Oil Filter (spin-on type)	1

ITEM NO.	PART NUMBER	DESCRIPTION	QTY.
7	5000-511-019	30kW 200L Frame 4 Pole B3 IE3 Foot Mount With Flange	1
8	5000-512-020	LS-BH30KW 30KW BELL HOUSING & COUPLING	1
9	5000-517-004	CAST IRON TRIPLE PUMP 33cc/33cc/10cc	1
10	5000-421-003	CETOP 5 Double Solenoid Valve	2
11	5000-441-009		3
12	5000-441-006	MPF1811AG1P25NBP	1

ITEM NO.	PART NUMBER	DESCRIPTION	Default/QTY.
13	1049-200-A40		1

M&K Quarry Plant Ltd - M&K Recycling Solutions Ltd 55 Cappagh Road, Galbally, Dungannon Co Tyrone, N Ireland, BT70 2PE t - +(0)44 28 8775 8396 f - +(0)44 28 8775 8557			UNLESS OTHERWISE SPECIFIED: DIMENSIONS ARE IN MILLIMETERS TOLERANCES: 0 - ±1.0mm 0.0 - ±0.25mm 0.00 - ±0.05mm ANGLES - ±0.5°	NOTES: 1. ALL DIMENSIONS SUBJECT TO MODIFICATION ON COMPLETION OF DETAILED DESIGNS 2. ALL CIVILS WORKS TO BE CARRIED OUT BY CUSTOMER FOUNDATION LOADINGS ON REQUEST FROM THE MK GROUP 3. RECOMMENDED MAGNET LOCATION IS AFTER THE PICKING STATION. OTHER POSITIONS WILL POTENTIALLY CAUSE JAMMINGPOINTS. IF MAGNET MUST BE FITTED OTHER THAN ABOVE THEN CORRECT PRE-SORTING OF MATERIAL IS ESSENTIAL.	DEBUR AND BREAK SHARP EDGES	DO NOT SCALE DRAWING THRID ANGLE PROJECTION
REVISION				TITLE:		
DRAWN CHK'D APPV'D MFG Q.A	NAME 	SIGNATURE 	DATE 13/03/2020	M&K Quarry Plant Ltd - M&K Recycling Solutions Ltd THIS DRAWING AND DESIGN IS THE PROPERTY OF M&K QUARRY PLANT Ltd - M&K RECYCLING SOLUTIONS Ltd. IT MUST NOT BE COPIED OR SUBMITTED TO A THIRD PARTY WITHOUT THE WRITTEN CONSENT OF M&K QUARRY PLANT Ltd - M&K RECYCLING SOLUTIONS Ltd.	DWG NO. 1049 TPS GA REV G	A3
WEIGHT:				SCALE: NTS	SHEET 1 OF 1	

REV 'A'	REV 'B'	REV 'C'	REV 'D'	REV 'E'
---------	---------	---------	---------	---------

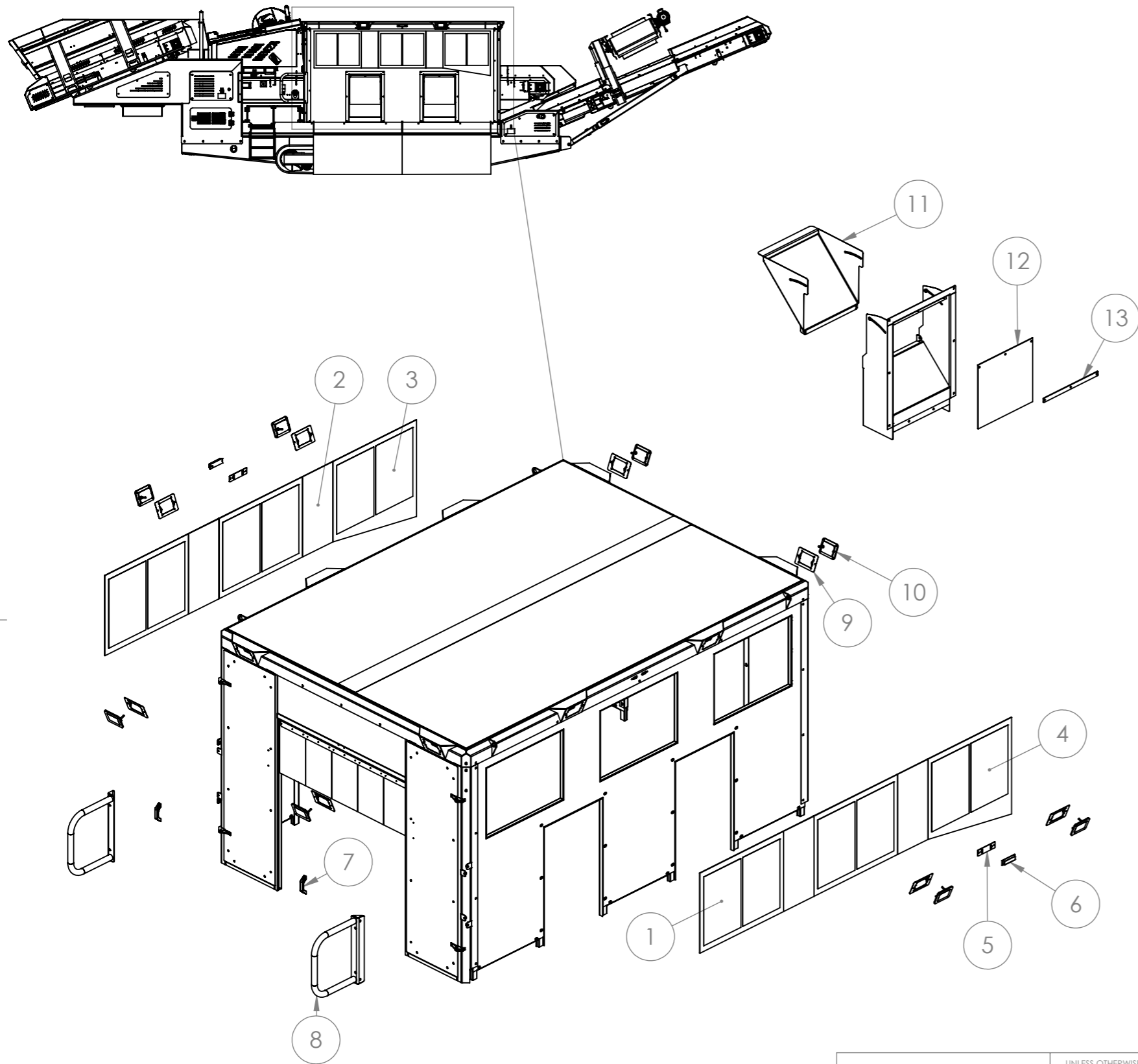

ITEM NO.	PART NUMBER	DESCRIPTION	QTY.
1	1049-800-094	Bonded Window 965mm x 755mm	4
2	1049-800-095	Bonded Window Blank 350x755	4
3	1049-800-096	Bonded Window Ski Slope 965x910x755mm	1
4	1049-800-097	Bonded Window Ski Slope 965x910x755mm	1
5	1049-800-090		2
6	5000-750-011	Cabin Strobe Light	2
7	1049-800-A26A		1
8	1049-200-A25	Handrill Assembly 1 Platform Tail	2
ITEM NO.	PART NUMBER	DESCRIPTION	Default/QTY.
9	1049-800-A03		8
ITEM NO.	PART NUMBER	DESCRIPTION	QTY.
10	5000-750-010	ICE 20B 20W SLimline Floodlight	8
ITEM NO.	PART NUMBER	DESCRIPTION	Default/QTY.
11	1049-200-A06		1
12	1049-200-055A	Chute Rubber Curtain	1
13	1049-200-056	Rubber Strap	1

M&K Quarry Plant Ltd - M&K Recycling Solutions Ltd
 55 Cappagh Road, Galbally, Dungannon Co Tyrone, N Ireland, BT70 2PE
 t - +(0)44 28 8775 8396
 f - +(0)44 28 8775 8557

UNLESS OTHERWISE SPECIFIED:
 DIMENSIONS ARE IN MILLIMETERS
 TOLERANCES:
 0 - ±1.0mm
 0.0 - ±0.25mm
 0.00 - ±0.05mm
 ANGLES - ±0.5°

NOTES:
 1. ALL DIMENSIONS SUBJECT TO MODIFICATION ON COMPLETION OF DETAILED DESIGNS
 2. ALL CIVILS WORKS TO BE CARRIED OUT BY CUSTOMER FOUNDATION LOADINGS ON REQUEST FROM THE MK GROUP
 3. RECOMMENDED MAGNET LOCATION IS AFTER THE PICKING STATION. OTHER POSITIONS WILL POTENTIALLY CAUSE JAMMINGPOINTS. IF MAGNET MUST BE FITTED OTHER THAN ABOVE THEN CORRECT PRE-SORTING OF MATERIAL IS ESSENTIAL.

DEBUR AND BREAK SHARP EDGES

DO NOT SCALE DRAWING THRID ANGLE PROJECTION

REV 'A'	REV 'B'	REV 'C'	REV 'D'	REV 'E'
---------	---------	---------	---------	---------

	NAME	SIGNATURE	DATE
DRAWN			12/03/2020
CHK'D			
APPV'D			
MFG			
Q.A			

M&K Quarry Plant Ltd - M&K Recycling Solutions Ltd
 THIS DRAWING AND DESIGN IS THE PROPERTY OF M&K QUARRY PLANT Ltd - M&K RECYCLING SOLUTIONS Ltd. IT MUST NOT BE COPIED OR SUBMITTED TO A THIRD PARTY WITHOUT THE WRITTEN CONSENT OF M&K QUARRY PLANT Ltd - M&K RECYCLING SOLUTIONS Ltd.

REVISION		TITLE:
DWG NO.	1049 TPS GA REV G	A3

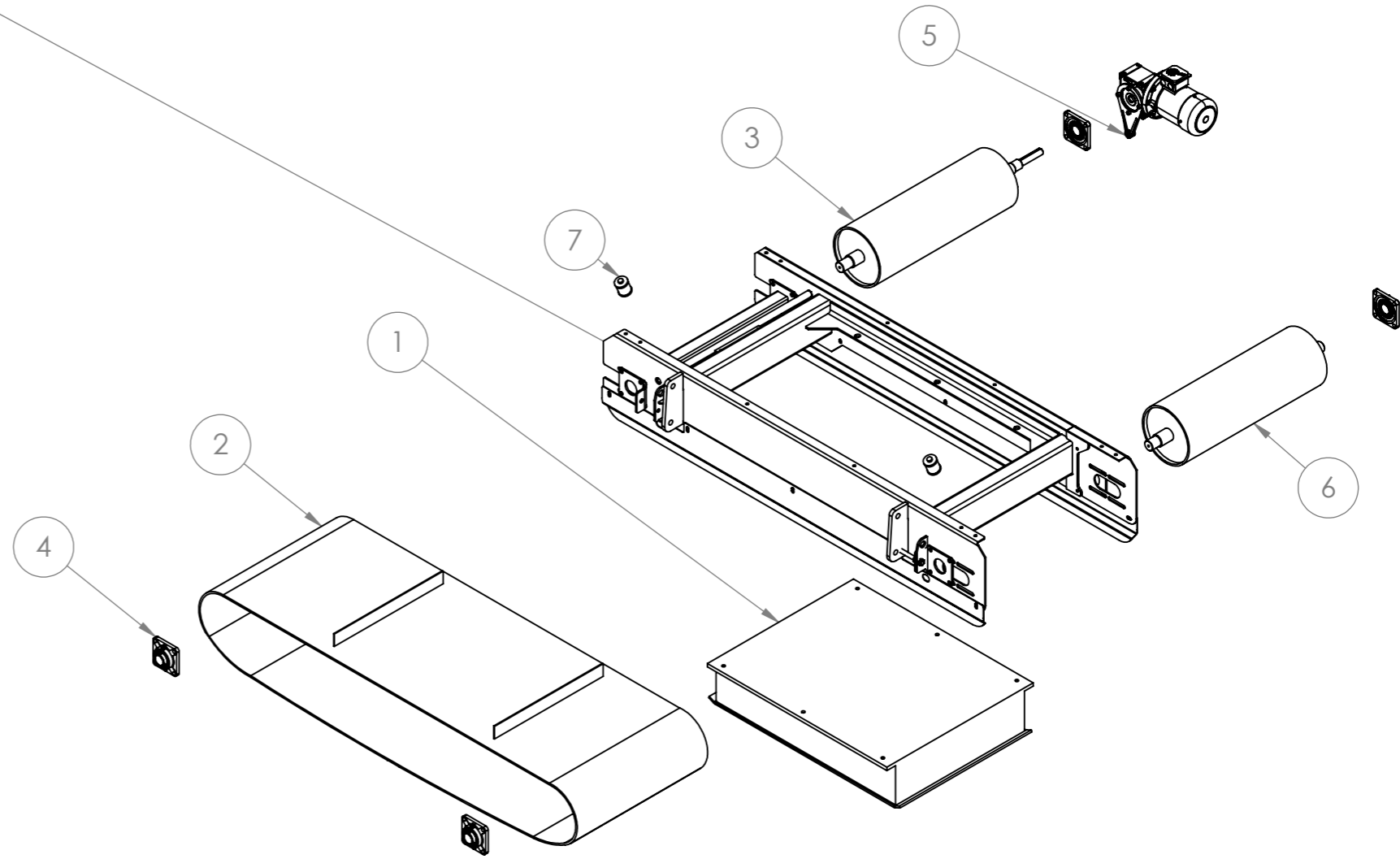
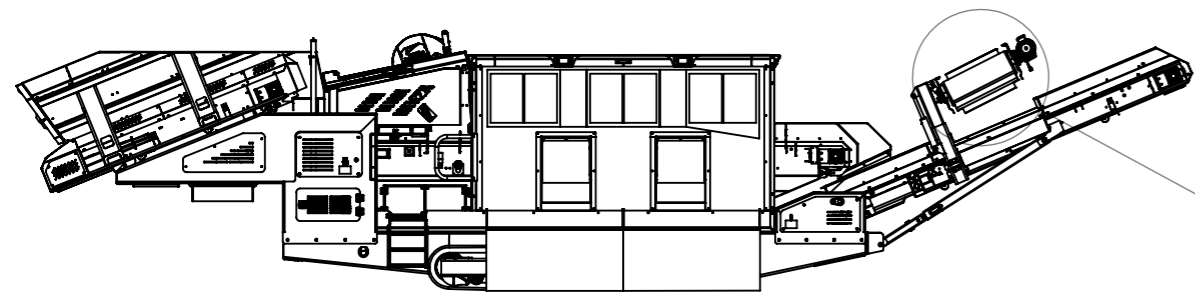

ITEM NO.	PART NUMBER	DESCRIPTION	QTY.
1	5000-900-017	12 PCB 8K Magnet Block	1
2	1049-700-154		1
3	1049-700-147A		1
4	5000-110-003	Square Flange Unit 55mm Bore	4
5	5000-510-005	3kW 101RPM 35mm Bore (Magnet Drive)	1
6	1049-700-136		1
7	5000-130-001	AutoGreaser	2

REV 'A'	REV 'B'	REV 'C'	REV 'D'	REV 'E'
---------	---------	---------	---------	---------

M&K Quarry Plant Ltd - M&K Recycling Solutions Ltd
 55 Cappagh Road, Galbally, Dungannon Co Tyrone, N Ireland, BT70 2PE
 t - +(0)44 28 8775 8396
 f - +(0)44 28 8775 8557

UNLESS OTHERWISE SPECIFIED: DIMENSIONS ARE IN MILLIMETERS TOLERANCES:
 0 - ±1.0mm
 0.0 - ±0.25mm
 0.00 - ±0.05mm
 ANGLES - ±0.5°

NOTES:
 1. ALL DIMENSIONS SUBJECT TO MODIFICATION ON COMPLETION OF DETAILED DESIGNS
 2. ALL CIVILS WORKS TO BE CARRIED OUT BY CUSTOMER FOUNDATION LOADINGS ON REQUEST FROM THE MK GROUP
 3. RECOMMENDED MAGNET LOCATION IS AFTER THE PICKING STATION. OTHER POSITIONS WILL POTENTIALLY CAUSE JAMMINGPOINTS. IF MAGNET MUST BE FITTED OTHER THAN ABOVE THEN CORRECT PRE-SORTING OF MATERIAL IS ESSENTIAL.

DEBUR AND BREAK SHARP EDGES

DO NOT SCALE DRAWING THRID ANGLE PROJECTION

	NAME	SIGNATURE	DATE
DRAWN			12/03/2020
CHK'D			
APPV'D			
MFG			
Q.A			

M&K Quarry Plant Ltd - M&K Recycling Solutions Ltd
 THIS DRAWING AND DESIGN IS THE PROPERTY OF M&K QUARRY PLANT Ltd - M&K RECYCLING SOLUTIONS Ltd. IT MUST NOT BE COPIED OR SUBMITTED TO A THIRD PARTY WITHOUT THE WRITTEN CONSENT OF M&K QUARRY PLANT Ltd - M&K RECYCLING SOLUTIONS Ltd.

REVISION		TITLE:
DWG NO.	1049 TPS GA REV G	A3

WEIGHT: SCALE: NTS SHEET 1 OF 1

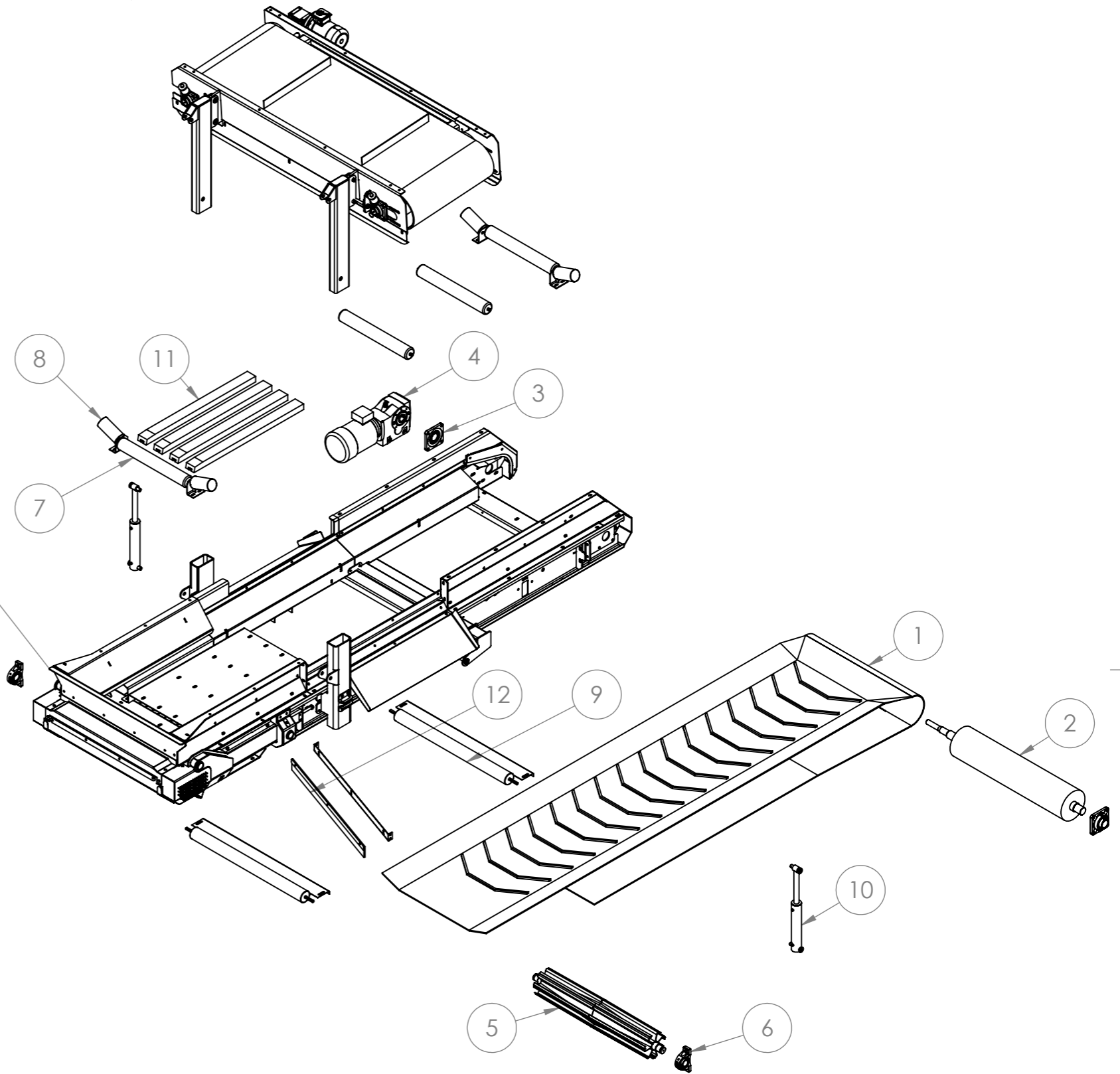
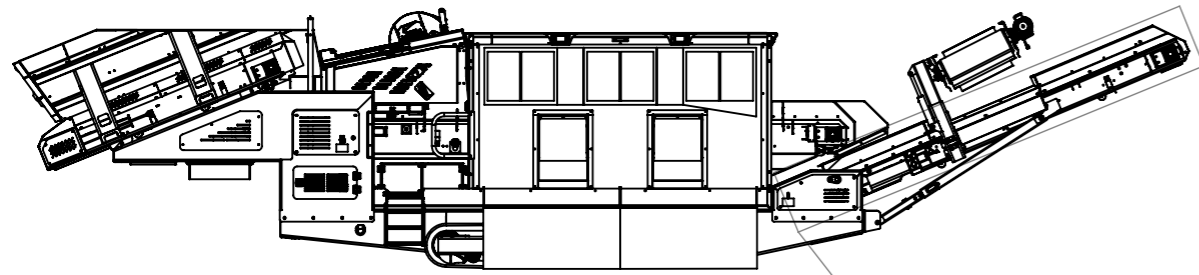

ITEM NO.	PART NUMBER	DESCRIPTION	Default/QTY.
1	1049-700-187		1
2	1020-300-007B	1200 Wide Conveyor Drive Drum	1
3	5000-110-001	Square Flange Unit FYH UCF 313 65mm Bore	2
4	5000-510-004	5.5kW 49RPM 50mm Bore (Conveyor Drive 49)	1
5	1020-300-A03A	1200 Wide Tail Drum Asm	1
6	5000-120-001	Normal Duty Pillow Block 55mm Bore	2
7	1020-400-003	1200 Wide Load Roller	4
8	1020-400-009	20 Degree Wing Roller	4
9	1020-400-018	1200 Wide Return Roller	2
10	5000-410-026	45-25-200	2
ITEM NO.	PART NUMBER	DESCRIPTION	Default/QTY.
11	5000-360-001	Impact Bar	4
ITEM NO.	PART NUMBER	DESCRIPTION	Default/QTY.
12	1020-700-035	1200 Wide Return Scaper Blade	1

REV 'A'	REV 'B'	REV 'C'	REV 'D'	REV 'E'

M&K Quarry Plant Ltd - M&K Recycling Solutions Ltd 55 Cappagh Road, Galbally, Dungannon Co Tyrone, N Ireland, BT70 2PE t - +(0)44 28 8775 8396 f - +(0)44 28 8775 8557		UNLESS OTHERWISE SPECIFIED: DIMENSIONS ARE IN MILLIMETERS TOLERANCES: 0 - ±1.0mm 0.0 - ±0.25mm 0.00 - ±0.05mm ANGLES - ±0.5°	NOTES: 1. ALL DIMENSIONS SUBJECT TO MODIFICATION ON COMPLETION OF DETAILED DESIGNS 2. ALL CIVILS WORKS TO BE CARRIED OUT BY CUSTOMER FOUNDATION LOADINGS ON REQUEST FROM THE MK GROUP 3. RECOMMENDED MAGNET LOCATION IS AFTER THE PICKING STATION. OTHER POSITIONS WILL POTENTIALLY CAUSE JAMMINGPOINTS. IF MAGNET MUST BE FITTED OTHER THAN ABOVE THEN CORRECT PRE-SORTING OF MATERIAL IS ESSENTIAL.	DEBUR AND BREAK SHARP EDGES	DO NOT SCALE DRAWING THRID ANGLE PROJECTION
DRAWN: _____ CHK'D: _____ APPV'D: _____ MFG: _____ Q.A: _____		NAME: _____ SIGNATURE: _____ DATE: 13/03/2020		M&K Quarry Plant Ltd - M&K Recycling Solutions Ltd THIS DRAWING AND DESIGN IS THE PROPERTY OF M&K QUARRY PLANT Ltd - M&K RECYCLING SOLUTIONS Ltd. IT MUST NOT BE COPIED OR SUBMITTED TO A THIRD PARTY WITHOUT THE WRITTEN CONSENT OF M&K QUARRY PLANT Ltd - M&K RECYCLING SOLUTIONS Ltd.	
MATERIAL: _____ WEIGHT: _____		TITLE: _____ DWG NO. 1049 TPS GA REV G SCALE: NTS SHEET 1 OF 1		A3	

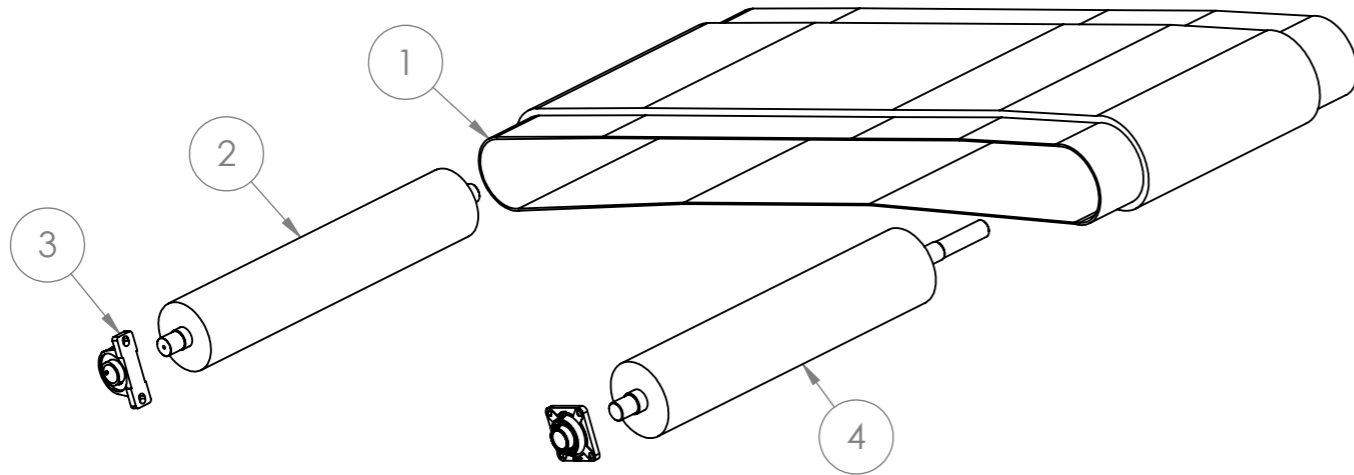
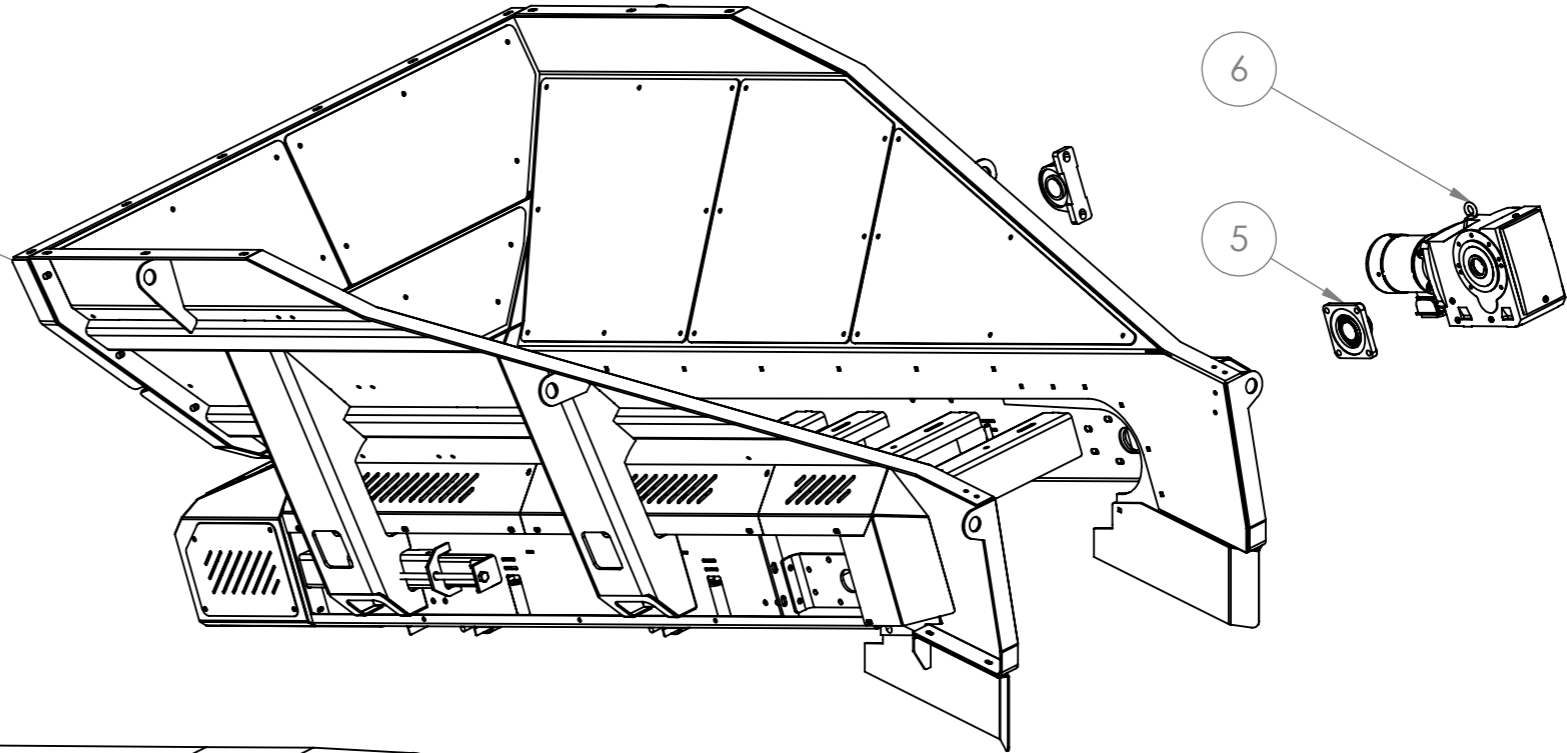
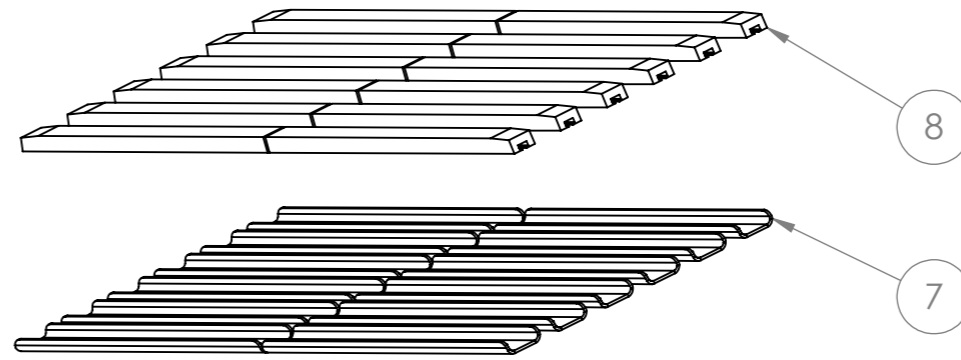
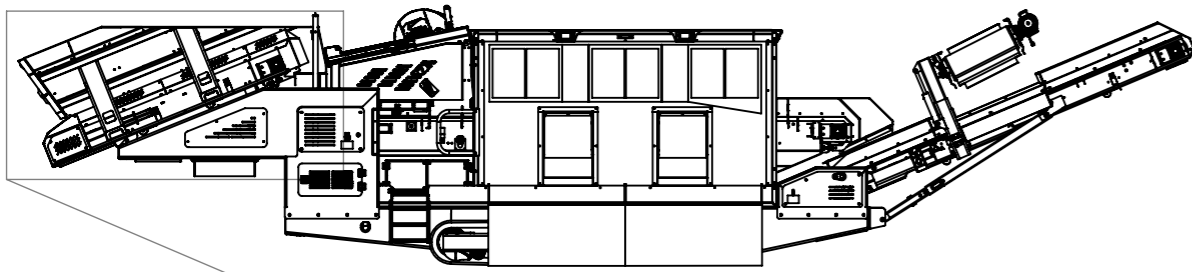

ITEM NO.	PART NUMBER	DESCRIPTION	Default/QTY.
1	1049-300-062	1200mm Belt	1
2	1030-200-014	1200 Wide Tail Idle Drum	1
3	5000-120-002	Pillow Block 2.5	2
4	1030-200-011	1200 Wide Belt Feeder Drive Drum	1
5	5000-110-001	Square Flange Unit FYH UCF 313 65mm Bore	2
6	5000-510-002	2.2kW 4RPM 60mm Bore (Feeder Drive)	1
7	1049-300-166		12
8	5000-360-001	Impact Bar	12

M&K Quarry Plant Ltd - M&K Recycling Solutions Ltd
 55 Cappagh Road, Galbally, Dungannon Co Tyrone, N Ireland, BT70 2PE
 t - +(0)44 28 8775 8396
 f - +(0)44 28 8775 8557

UNLESS OTHERWISE SPECIFIED: DIMENSIONS ARE IN MILLIMETERS TOLERANCES:
 0 - ±1.0mm
 0.0 - ±0.25mm
 0.00 - ±0.05mm
 ANGLES - ±0.5°

NOTES:
 1. ALL DIMENSIONS SUBJECT TO MODIFICATION ON COMPLETION OF DETAILED DESIGNS
 2. ALL CIVILS WORKS TO BE CARRIED OUT BY CUSTOMER FOUNDATION LOADINGS ON REQUEST FROM THE MK GROUP
 3. RECOMMENDED MAGNET LOCATION IS AFTER THE PICKING STATION. OTHER POSITIONS WILL POTENTIALLY CAUSE JAMMINGPOINTS. IF MAGNET MUST BE FITTED OTHER THAN ABOVE THEN CORRECT PRE-SORTING OF MATERIAL IS ESSENTIAL.

DEBUR AND BREAK SHARP EDGES

DO NOT SCALE DRAWING

THRID ANGLE PROJECTION



REVISION

REV 'A'

REV 'B'

REV 'C'

REV 'D'

REV 'E'

NAME	SIGNATURE	DATE
DRAWN		12/03/2020
CHK'D		
APPV'D		
MFG		
Q.A		

M&K Quarry Plant Ltd - M&K Recycling Solutions Ltd
 THIS DRAWING AND DESIGN IS THE PROPERTY OF M&K QUARRY PLANT Ltd - M&K RECYCLING SOLUTIONS Ltd. IT MUST NOT BE COPIED OR SUBMITTED TO A THIRD PARTY WITHOUT THE WRITTEN CONSENT OF M&K QUARRY PLANT Ltd - M&K RECYCLING SOLUTIONS Ltd.

TITLE:
 DWG NO. 1049 TPS GA REV G
 A3

MATERIAL:

WEIGHT:

SCALE: NTS

SHEET 1 OF 1