



Haworth Scouring.

15th Sept 2025
Update 21 Jan 2026
Update 27 Jan 2026

System P&ID

Digestate & Water

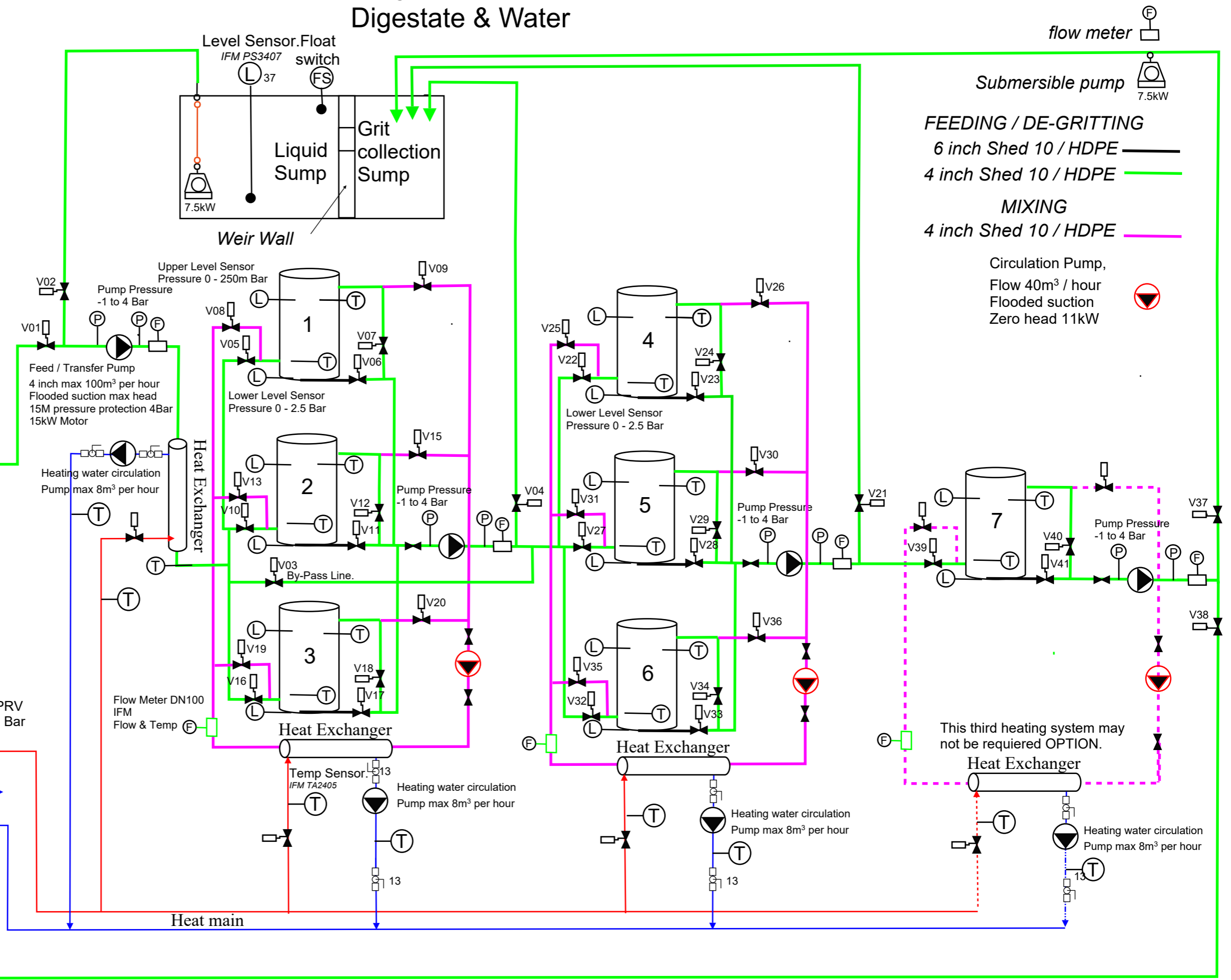
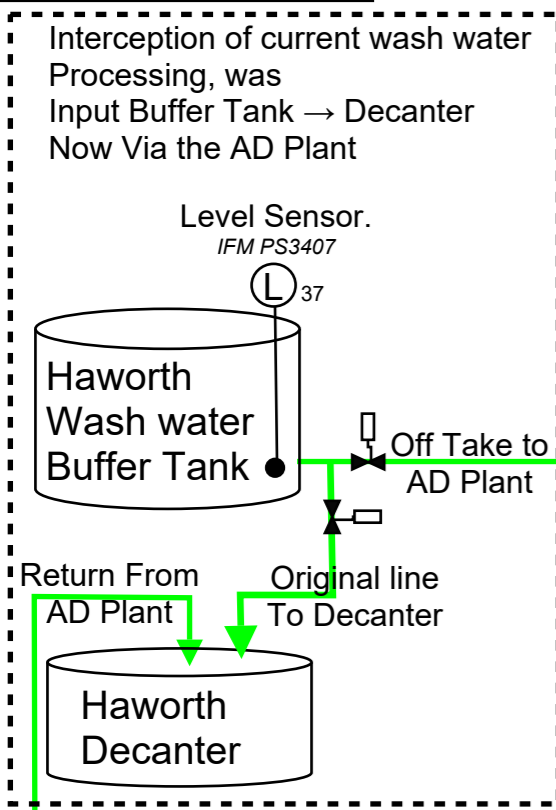

flow meter

Submersible pump 7.5kW

FEEDING / DE-GRITTING
6 inch Shed 10 / HDPE
4 inch Shed 10 / HDPE

MIXING
4 inch Shed 10 / HDPE

Circulation Pump,
Flow 40m³ / hour
Flooded suction
Zero head 11kW

This third heating system may not be required OPTION.

Heat Exchanger

Heating water circulation Pump max 8m³ per hour

System P&ID

Gas, Tank protection and mixing

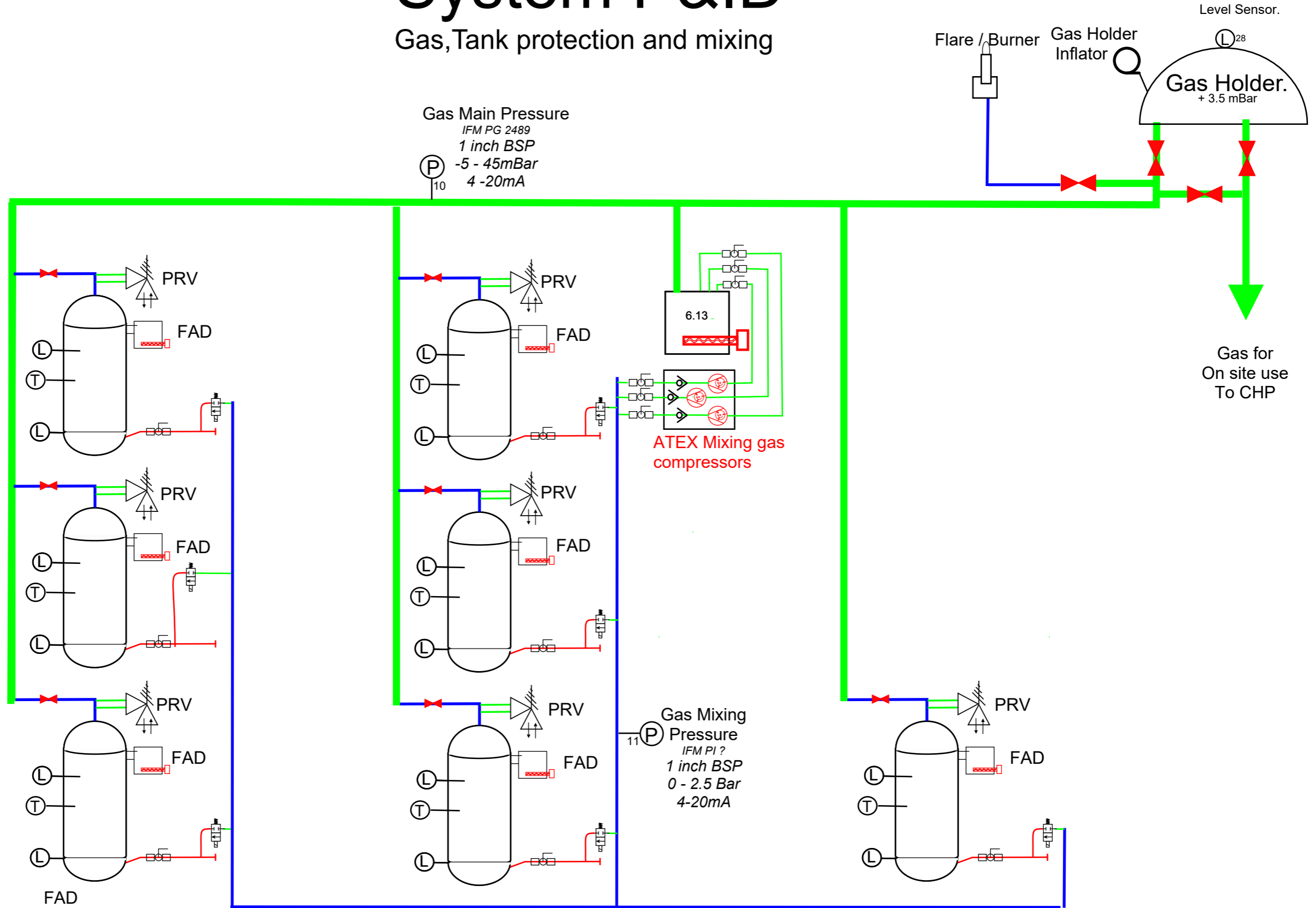

Condensation /
Anti Implosion
Under pressure
- 2 mBar

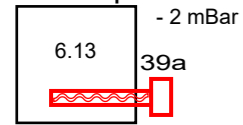

Atex Anti Frost

FAD
Foam Alleviation
/ Over pressure

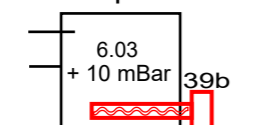

Atex Anti Frost

Gas Pressure
IFM PG 2489
1 inch BSP
-5 - 100mBar P₁₀

Gas Pressure
IFM PI ?
1 inch BSP
0 - 4 Bar P₁₁

Air operated
Gas solenoids

ATEX Mixing gas
compressors

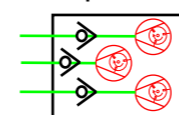

PRV
Pressure Relief
4 inch BSP
+6 mBar
-1.5 mBar

6 inch gas main Dairy
4 inch gas main M'press
1 inch gas pipe M'press
1 inch gas pipe Shed 10

